

# Conductor Bar Manual

## 8-Bar

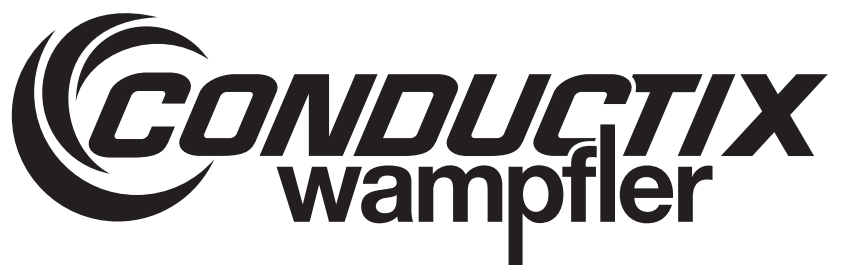

## CONDUCTIX INCORPORATED

The technical data and images which appear in this manual are for informational purposes only. **NO WARRANTIES, EXPRESS OR IMPLIED, INCLUDING WARRANTIES OF MERCHANTABILITY OR FITNESS FOR A PARTICULAR PURPOSE, ARE CREATED BY THE DESCRIPTIONS AND DEPICTIONS OF THE PRODUCTS SHOWN IN THIS MANUAL.** Conductix makes no warranty (and assumes no liability) as to function of equipment or operation of systems built according to customer design or of the ability of any of its products to interface, operate or function with any portions of customer systems not provided by Conductix.

Seller agrees to repair or exchange the goods sold hereunder necessitated by reason of defective workmanship and material discovered and reported to Seller within one year after shipment of such goods to Buyer.

Except where the nature of the defect is such that it is appropriate, in Seller's judgment, to effect repairs on site, Seller's obligation hereunder to remedy defects shall be limited to repairing or replacing (at Seller's option) FOB point of original shipment by Seller, any part returned to Seller at the risk and cost of Buyer. Defective parts replaced by Seller shall become the property of Seller.

Seller shall only be obligated to make such repair or replacement if the goods have been used by Buyer only in service recommended by Seller and altered only as authorized by Seller. Seller is not responsible for defects which arise from improper installation, neglect, or improper use or from normal wear and tear.

Additionally, Seller's obligation shall be limited by the manufacturer's warranty (and is not further warranted by Seller) for all parts procured from others according to published data, specifications or performance information not designed by or for Seller.

Seller further agrees to replace or at Seller's option to provide a refund of the sales price of any goods that do not conform to applicable specifications or which differ from that agreed to be supplied which non-conformity is discovered and forthwith reported to Seller within thirty (30) days after shipment to the Buyer. Seller's obligation to replace or refund the purchase price for non-conforming goods shall arise once Buyer returns such goods FOB point of original shipment by Seller at the risk and cost of Buyer. Goods replaced by Seller shall become the property of Seller.

There is no guarantee or warranty as to anything made or sold by Seller, or any services performed, except as to title and freedom from encumbrances and, except as herein expressly stated and particularly, and without limiting the foregoing, **there is no guarantee or warranty, express or implied, of merchantability or of fitness for any particular purpose or against claim of infringement or the like.**

Seller makes no warranty (and assumes no liability) as to function of equipment or operation of systems built to Buyer's design or of the ability of any goods to interface, operate or function with any portions of Buyer's system not provided by Seller.

Seller's liability on any claim, whether in contract, tort (including negligence), or otherwise, for any loss or damage arising out of, connected with, or resulting from the manufacture, sale, delivery, resale, repair, replacement or use of any products or services shall in no case exceed the price paid for the product or services or any part thereof which give rise to the claim. In no event shall Seller be liable for consequential, special, incidental or other damages, nor shall Seller be liable in respect of personal injury or damage to property not the subject matter hereof unless attributable to gross misconduct of Seller, which shall mean an act or omission by Seller demonstrating reckless disregard of the foreseeable consequences thereof.

Seller is not responsible for incorrect choice of models or where products are used in excess of their rated and recommended capacities and design functions or under abnormal conditions. Seller assumes no liability for loss of time, damage or injuries to property or persons resulting from the use of Seller's products. Buyer shall hold Seller harmless from all liability, claims, suits, and expenses in connection with loss or damage resulting from operation of products or utilization of services, respectively, of Seller and shall defend any suit or action which might arise there from in Buyer's name - provided that Seller shall have the right to elect to defend any such suit or action for the account of Buyer. The foregoing shall be the exclusive remedies of the Buyer and all persons and entities claiming through the Buyer.

## CONDUCTIX-WAMPFLER FIELD SERVICE

### Need Field Service for our products? We Can Handle It!

Ask us for a quote on expert system installations, inspections, preventative maintenance, and repairs/retrofits.

As the world's largest single source manufacturer of mobile electrification products, Conductix-Wampfler has the unique ability to offer a degree of service not found anywhere else. Conductix-Wampfler's team of highly qualified service technicians and engineers have years of experience servicing our complete line of products.

We can provide:

- **Annual service contracts**
- **Installation**
- **Commissioning**
- **Installation supervision** to ensure your installers avoid common mistakes.
- **Troubleshooting** to get you up and running.
- **Pre-planned inspections** to complement your preventive maintenance program.

**Call 1.800.521.4888 for further details.**



## TABLE OF CONTENTS

<b>SECTION 1 - TERMINOLOGY</b>	<b>6</b>
<b>SECTION 2 - SAFETY</b>	<b>7</b>
Safety Warnings	7
Safety Information Responsibility	7
Safety Messages	7
<b>SECTION 3 - INSTALLATION OVERVIEW</b>	<b>8</b>
Required Hand Tools	8
Basic 8-Bar Components	8
Storage	8
Standard Mounting	8
Lateral Mounting	8
Additional Information	8
<b>SECTION 4 - TYPICAL INSTALLATIONS</b>	<b>9</b>
Standard Vertical Mounting Web Brackets	9
“A” - Hanger/Conductor Bar/Collector Spacing	9
“B” - Support to Contact Surface	9
Standard Monorail / Under Hung Crane Application	10
Lateral Mounting	11
Plastic Snap-In Hanger Clamps	12
Steel Snap-In Hanger Clamps	13
Cross-Bolt Hanger Clamps	14
Anchor Clamps	15
<b>SECTION 5 - TYPICAL LAYOUT FOR STRAIGHT RUNWAYS</b>	<b>16</b>
<b>SECTION 6 - TYPICAL COLLECTOR MOUNTING</b>	<b>17</b>
Standard Vertical Mount	17
“C” Base - Standard Mount	17
“H” Base - Standard Mount	18
“C” Base - Tandem Mount	19
<b>SECTION 7 - TYPICAL EXPANSION GAP &amp; ANCHORING REQUIREMENTS</b>	<b>20</b>
Installation of Expansion Sections	20
Installation Overview	20
Expansion & Anchor Location Diagram	21
Anchors	21
<b>SECTION 8 - INSTALLATION PROCEDURE</b>	<b>22</b>

## TABLE OF CONTENTS

<b>SECTION 9 - SPECIAL APPLICATIONS</b>	<b>27</b>
Field Cutting	27
Curves	27
Discontinuous Systems	27
Interlock, Switches, or Fixed Gaps	28
Switches	28
<b>SECTION 10 - TROUBLESHOOTING</b>	<b>29</b>
<b>SECTION 11 - REPLACEMENT PARTS</b>	<b>30</b>

## SECTION 1 - TERMINOLOGY

### **Anchor Clamp**

Connects the bar to the structure and controls movement of the conductors during thermal expansion and contraction.

### **Anchor Tight**

The clamping force required to overcome movement due to the heating and cooling of the conductor bar.

### **Collector**

Transfers power from the bar to the moving machine. Connects to a 1" mounting staff.

### **End Cover**

Caps off the end of the conductor bar.

### **Hanger Bracket**

Attaches to crane beam or other structure to support multiple hangers.

### **Hanger Clamp**

Suspends the conductor bar from hanger bracket.

### **Power Feed**

Conducts the power source to the conductor bar.

### **Sliding Tight**

The clamping force required to hold the bar in place while allowing movement due to the heating and cooling of the conductor bar. Plastic and Steel Snap-In Hangers are both designed to provide a sliding tight fit. For metal hangers with cross bolts, tighten until .02-.05 inch clearance remains between the hanger clamp and the conductor bar.

### **NOTE**

- All hanger clamps that are not specified to be anchor tight must be installed sliding tight to assure reliable operation.

## SECTION 2 - SAFETY

### Safety Warnings

Disconnect power and follow all lock-out tag-out procedures as described in Appendix A of OSHA Section 1910.147.

All personnel must practice strict adherence to both local and national safety procedures, codes, regulations, and ordinances.

All personnel installing a power rail system should be familiar with the layout details and the component locations.

### WARNING

- The law recognizes that electrical energy as commonly utilized in industrial and transit operations is dangerous and capable of causing serious damage, injury, or death. Requirements governing the handling and use of electricity, some general and some very specific and detailed, are found in various statutes like the Workmen's Compensation Acts, Employer's Liability Acts, National Electrical Safety Code (U.S. Dept. of Commerce), Occupational Safety and Health Administration (OSHA), etc. and city or local ordinances. When using electrical power, the law imposes the general obligation to use care to protect against accidental injury or damage to properties.

### Safety Information Responsibility

All owner, operator, and maintenance personnel must read and understand all manuals associated with this product before installation, operation, or maintenance.

The manual provides information on the recommended installation, operation, and maintenance of this product. Failure to read and follow the information provided could cause harm to yourself or others and/or cause product damage. No one should install, operate, or attempt maintenance of this product prior to familiarizing themselves with the information in this manual.

### Safety Messages

Safety messages in this manual are preceded by the HAZARD SYMBOL and one of three words: CAUTION, DANGER, OR WARNING. These safety messages are intended to alert you to potential hazards that could cause harm to you or others and/or cause product damage.

### CAUTION

- The HAZARD SYMBOL used with the word CAUTION indicates unsafe actions or situations that have the potential to cause injury, and/or minor equipment or property damage.

### DANGER

- The HAZARD SYMBOL used with the word DANGER describes immediate hazards that have the potential to cause severe personal injury or death.

### WARNING

- The HAZARD SYMBOL used with the word WARNING describes unsafe actions or situations that have the potential to cause severe injury, death, and/or major equipment or property damage.

### NOTE

- The word NOTE is used to alert you to installation, operation, programming, or maintenance information that is important, but not hazard related.

## SECTION 3 - INSTALLATION OVERVIEW

### Required Hand Tools

- Torque Wrench
- Socket Wrench Set
- Small Ball Peen Hammer
- Hacksaw
- Screwdriver Set
- 3/8" Drill and Drill Bit Set
- Small File Set

### Basic 8-Bar Components

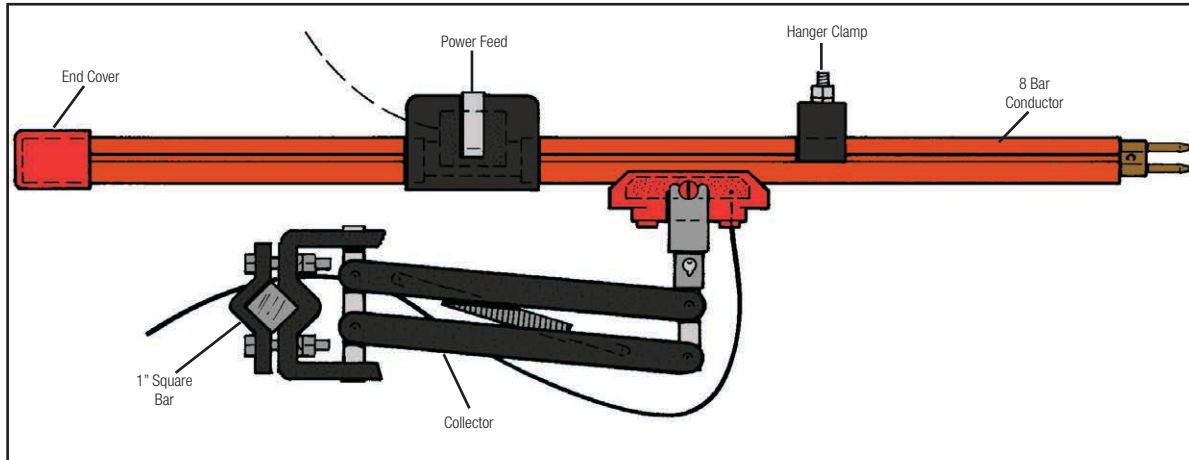

### Storage

Conductor bar should be stored overnight in the installation environment to assure that bar has equalized to the ambient air temperature. The bar must be installed with a relatively uniform temperature to allow proper gaging of the expansion section gap setting.

### Standard Mounting

Conductix-Wampfler 8-Bar is typically installed with bar profile oriented vertically and the collector shoe entering from the bottom.

Installations that operate in a wet or dirty atmosphere or corrosive environment must be vertically mounted.

### Lateral Mounting

Some installations require the collector shoe to enter from the side. Conductix-Wampfler 8-Bar can be adapted to this configuration when required. Consult the factory for further assistance.

### Additional Information

Any questions regarding the installation or use of Conductix-Wampfler 8-Bar that are not addressed in this manual can be answered by Conductix-Wampfler Engineering.

Contact the factory: **800-521-4888**



## SECTION 4 - TYPICAL INSTALLATIONS

### Standard Vertical Mounting Web Brackets

#### NOTE

- Mounting dimensions depend on bracket and hangers used in installation.

#### “A” - Hanger/Conductor Bar/Collector Spacing

- 3" Recommended
- 2" Minimum (Collectors Adjacent)
- 1.5" Minimum (Collectors Staggered)
- 3" or 4" when Pickup Guides are used
- 2" Minimum in systems with curve
- 2" Minimum (Insulated Hangers)

#### “B” - Support to Contact Surface

- 1.8" Plastic Snap-In, Cross-Bolt and Anchor Clamp with Spacer
- 1.4" Steel Snap-In and Anchor without Spacer

#### NOTE

- For hangers with insulators add 1" to above dimensions.

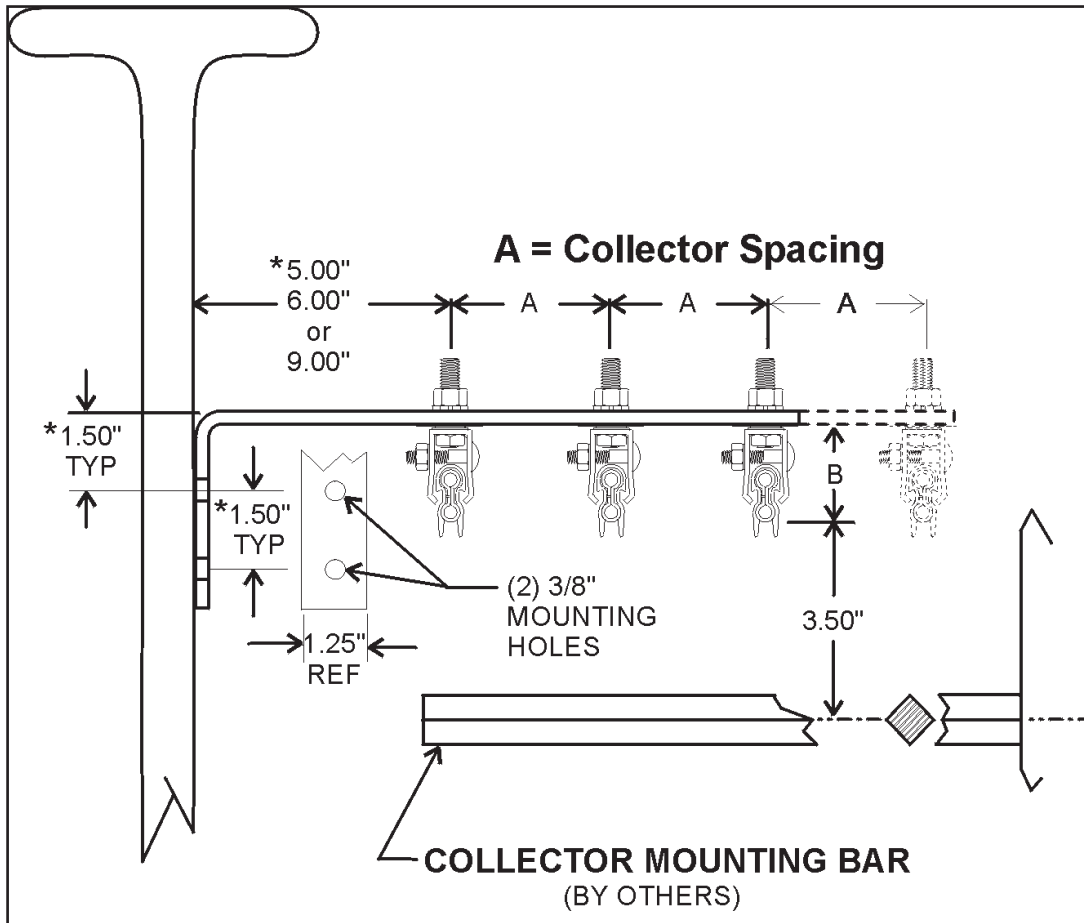

Figure 9-1

## SECTION 4 - TYPICAL INSTALLATIONS

### Standard Monorail / Under Hung Crane Application

- Flange Brackets

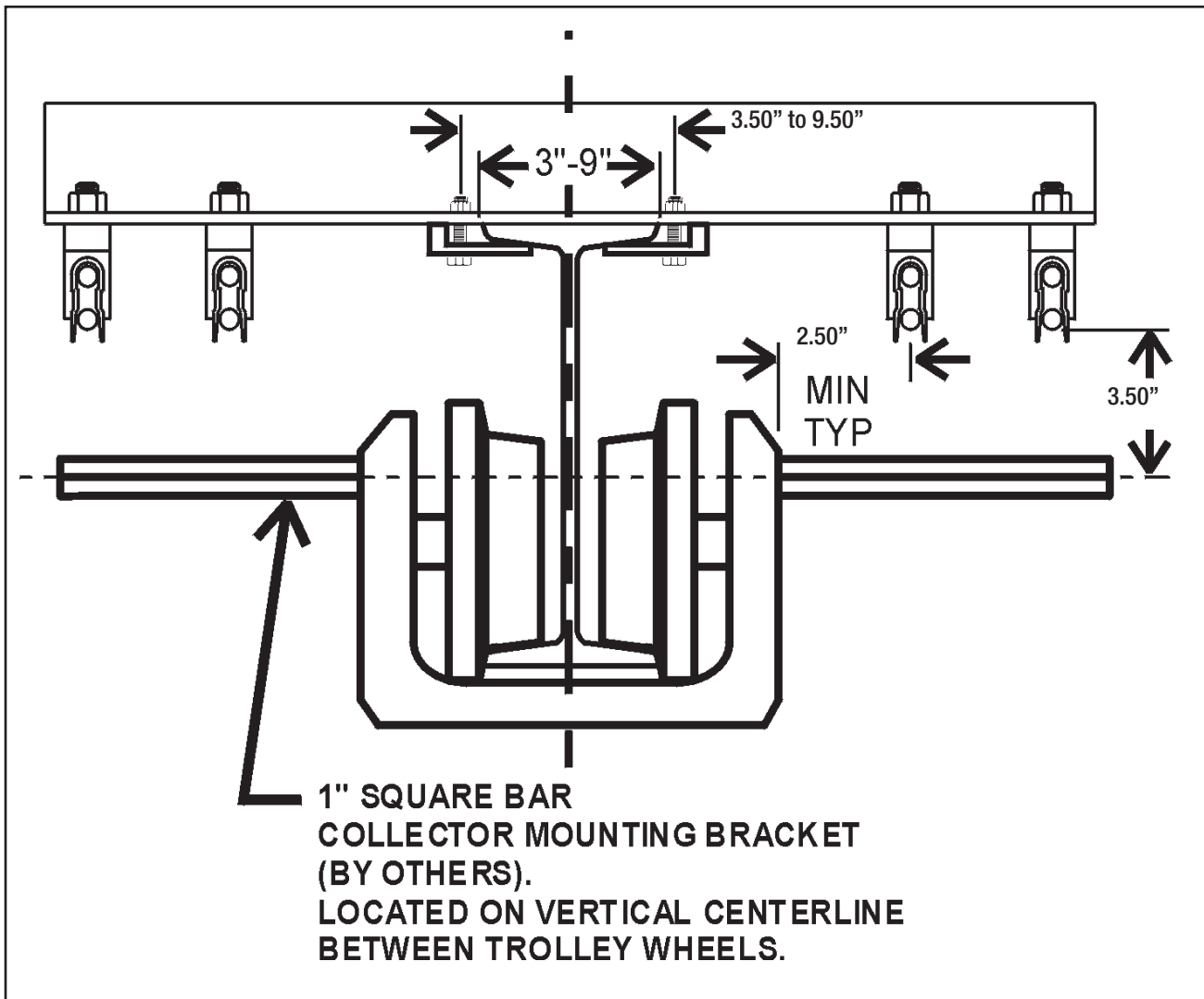

Figure 10-1

## SECTION 4 - TYPICAL INSTALLATIONS

### Lateral Mounting

#### NOTE

- Not recommended for wet or dirty environments.

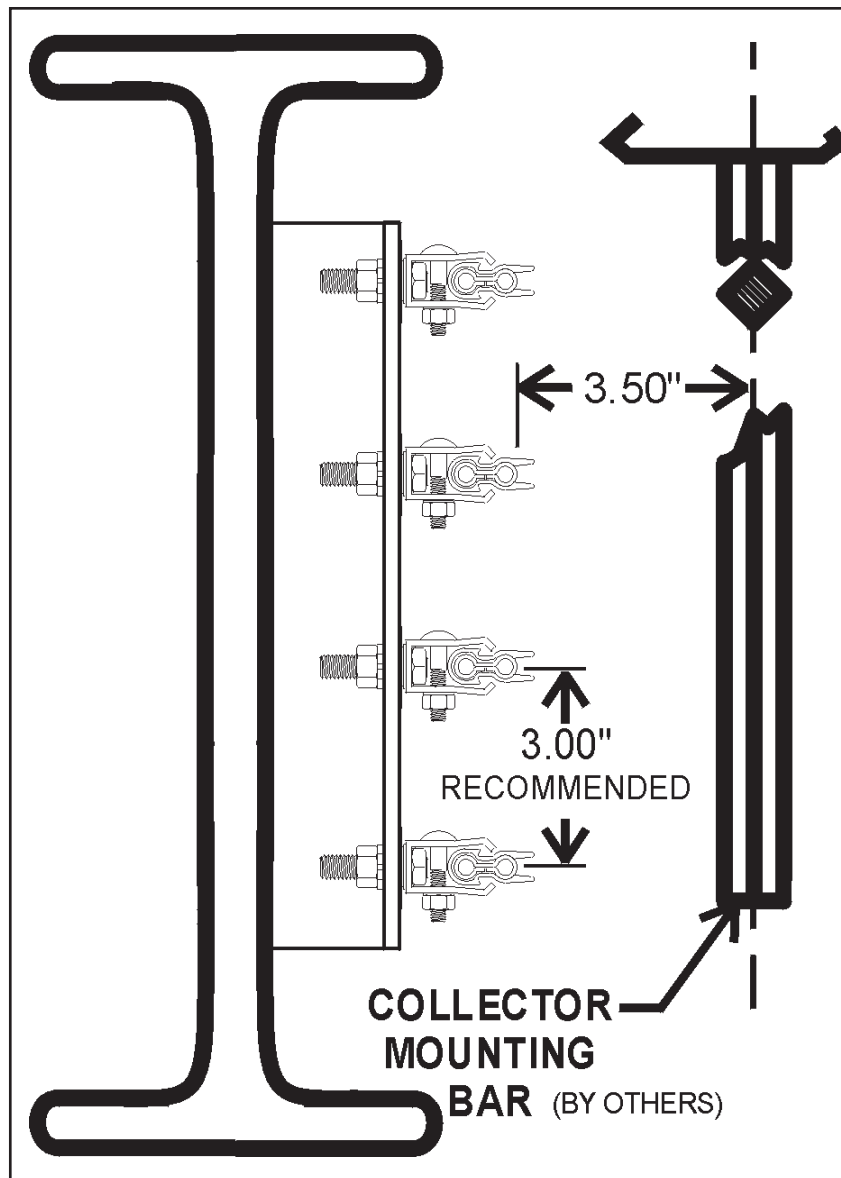

Figure 11-1

## SECTION 4 - TYPICAL INSTALLATIONS

### Plastic Snap-In Hanger Clamps

#### NOTE

- Not recommended for lateral mount or curves.

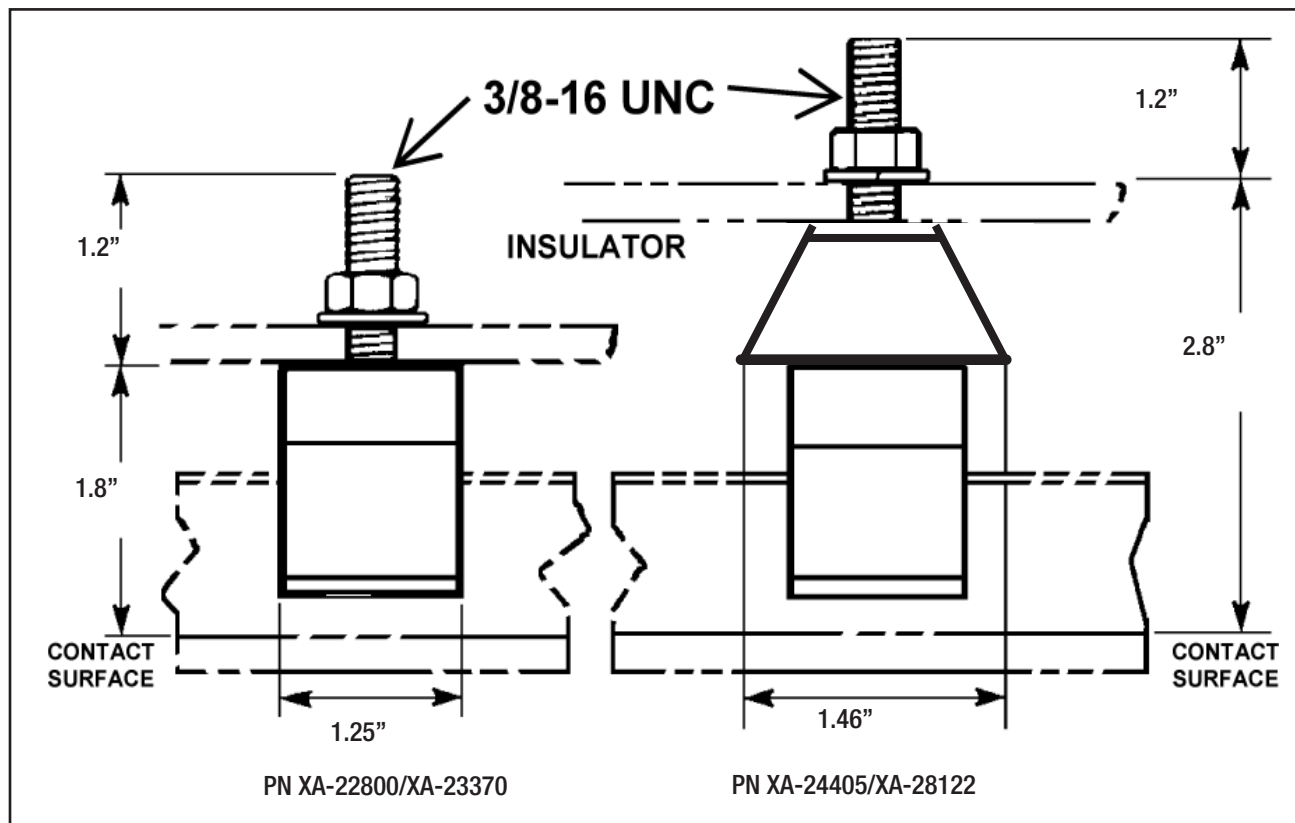

Figure 12-1

## SECTION 4 - TYPICAL INSTALLATIONS

### Steel Snap-In Hanger Clamps

#### NOTE

- Not recommended for lateral mount or curves.

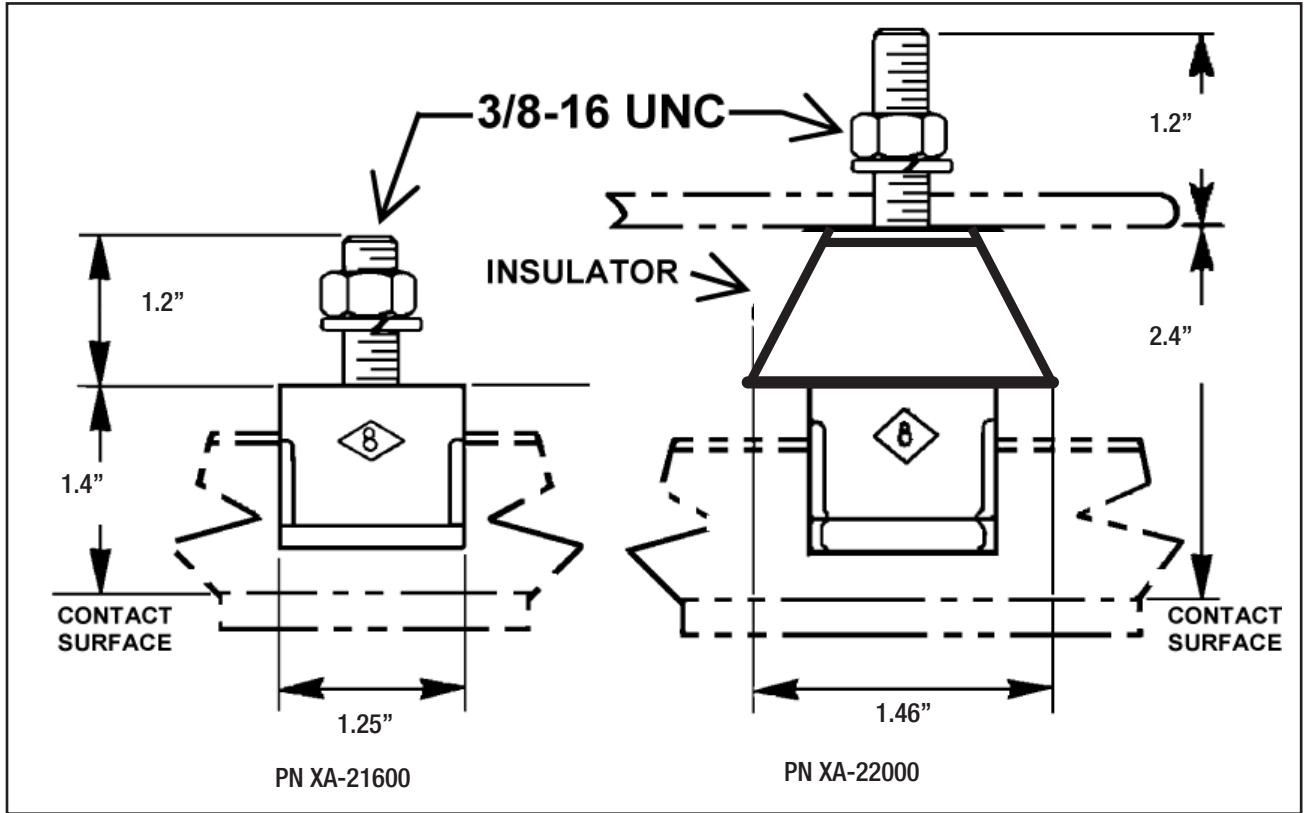

Figure 13-1

## SECTION 4 - TYPICAL INSTALLATIONS

### Cross-Bolt Hanger Clamps

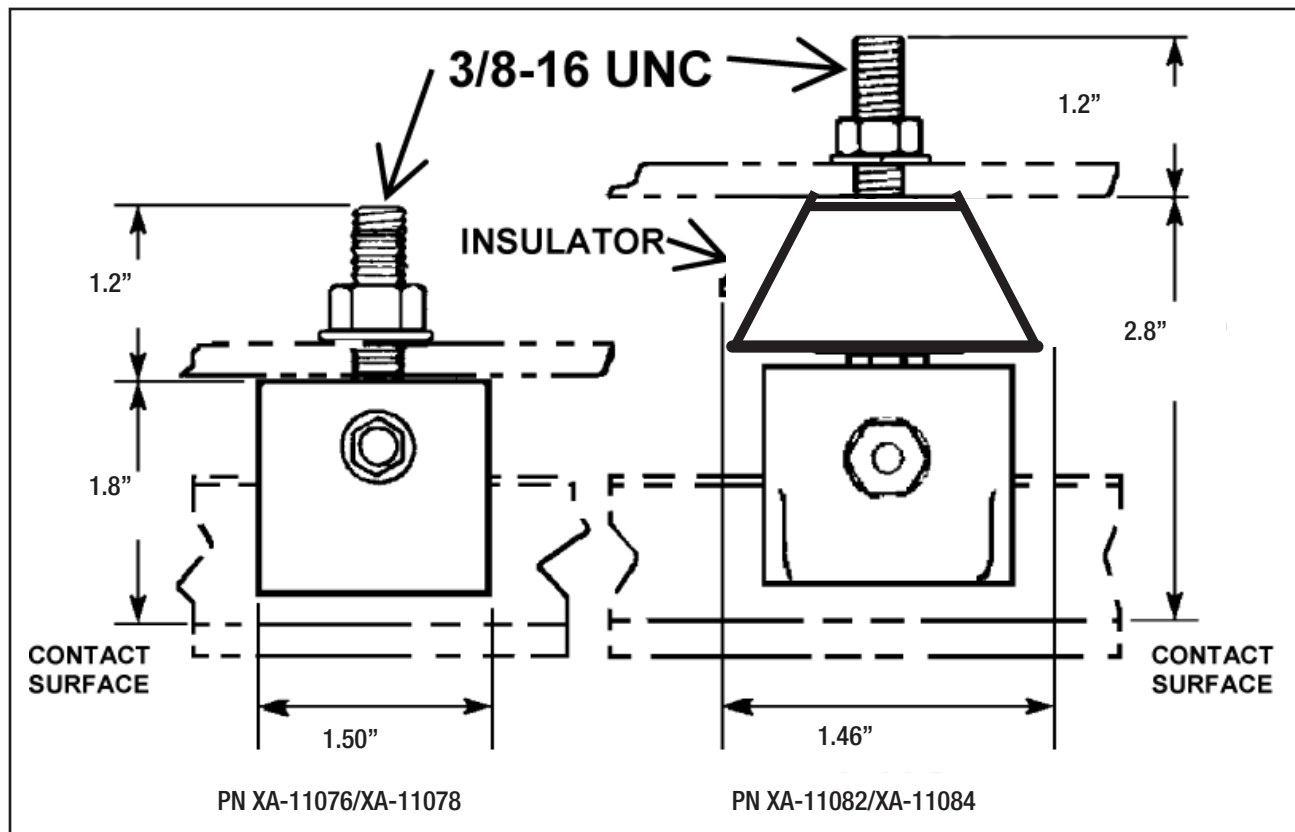

Figure 14-1

# SECTION 4 - TYPICAL INSTALLATIONS

## Anchor Clamps

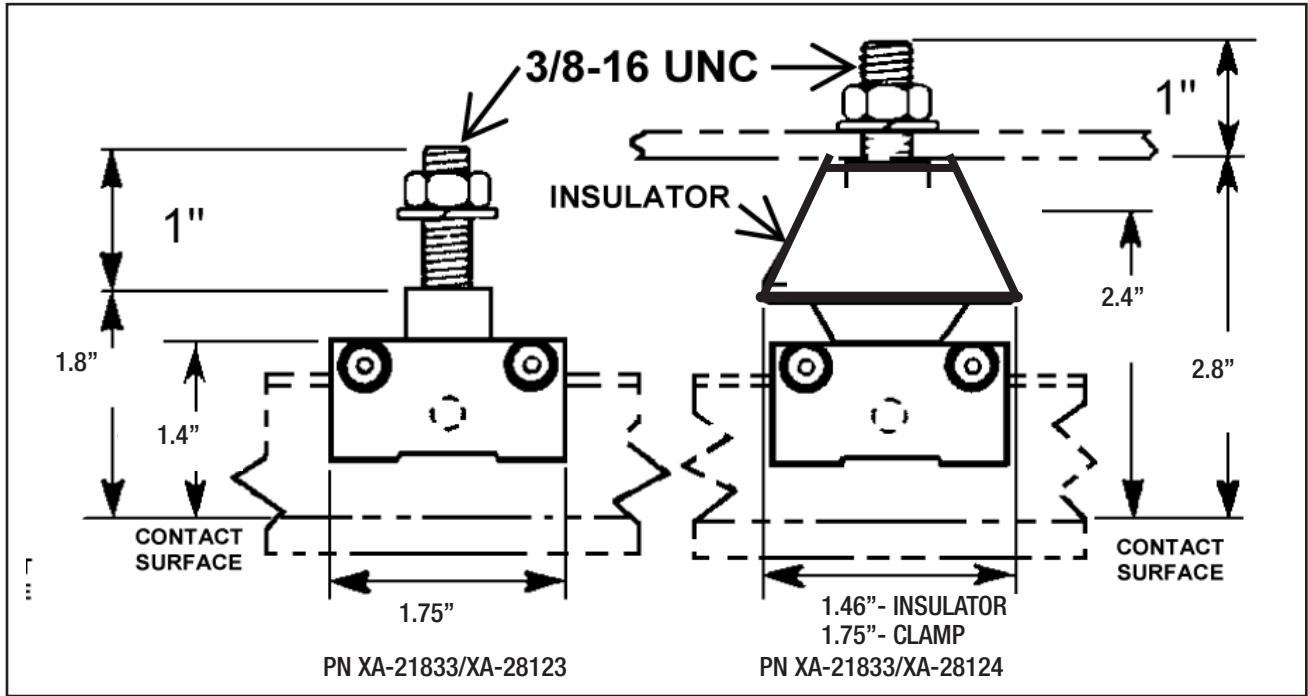

Figure 15-1

# SECTION 5 - TYPICAL LAYOUT FOR STRAIGHT RUNWAYS

## NOTE

- This information applies only to straight bottom entry runway installations of conductor bar. Installations that include curved sections require special consideration. Please contact the factory for assistance.

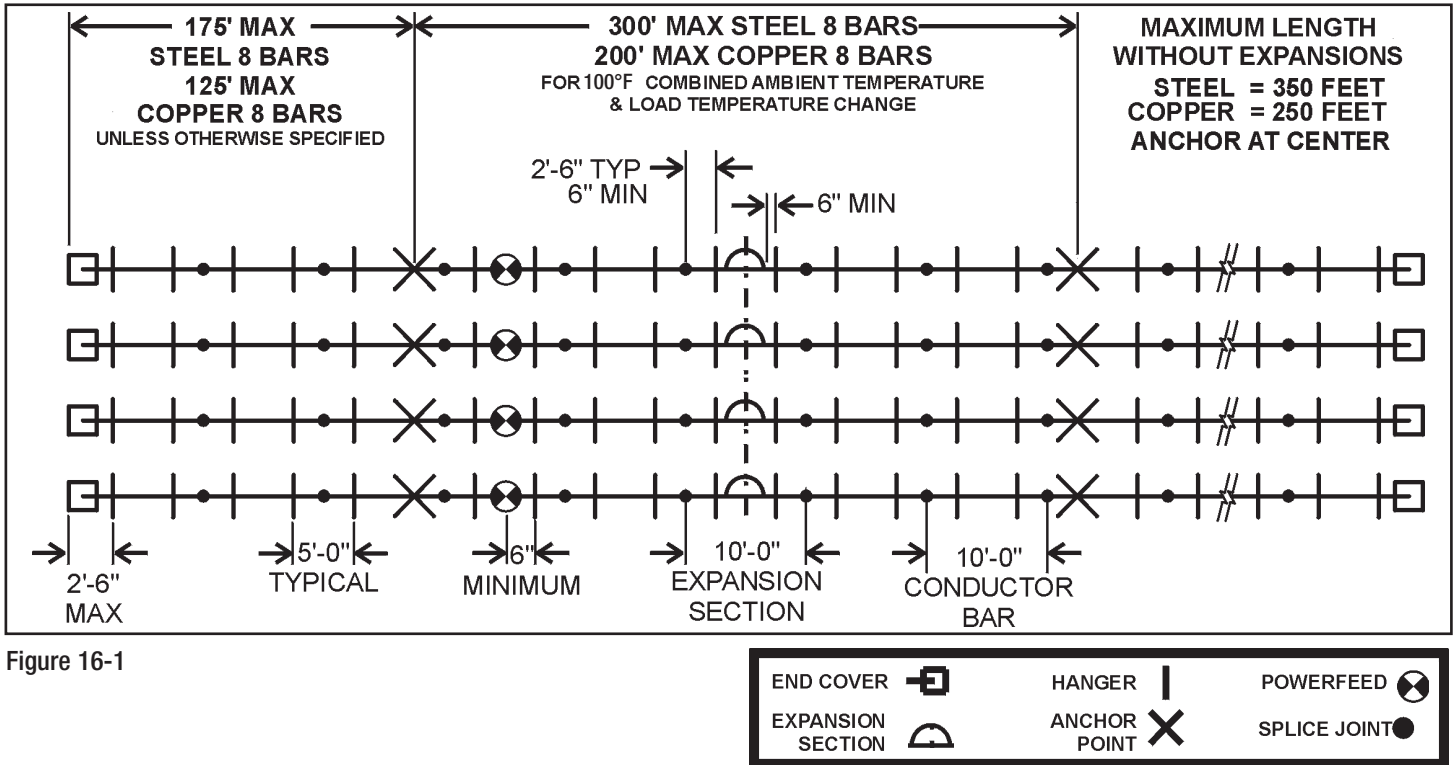

Figure 16-1



## SECTION 6 - TYPICAL COLLECTOR MOUNTING

### Standard Vertical Mount "C" Base - Standard Mount

#### NOTE

- Torque mounting hardware to 8 - 10 ft lbs.

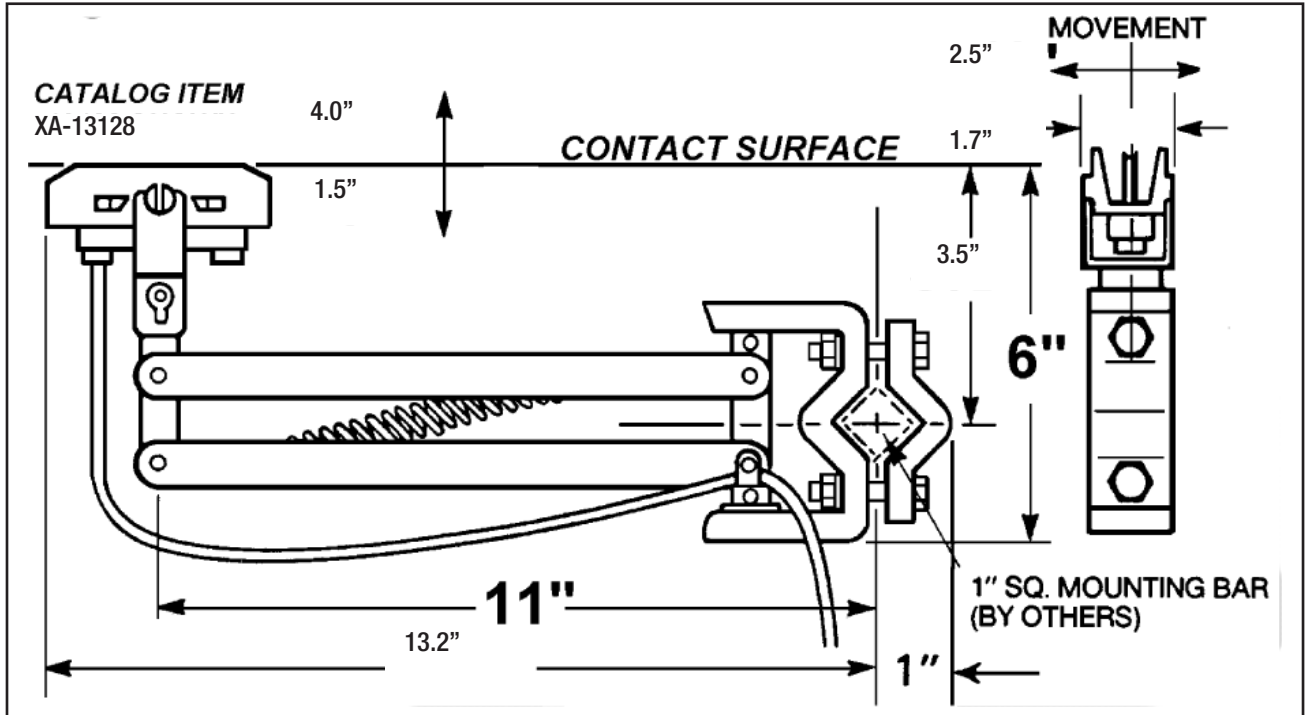

Figure 17-1

## SECTION 6 - TYPICAL COLLECTOR MOUNTING

### "H" Base - Standard Mount

#### NOTE

- Torque mounting hardware to 8 - 10 ft lbs.

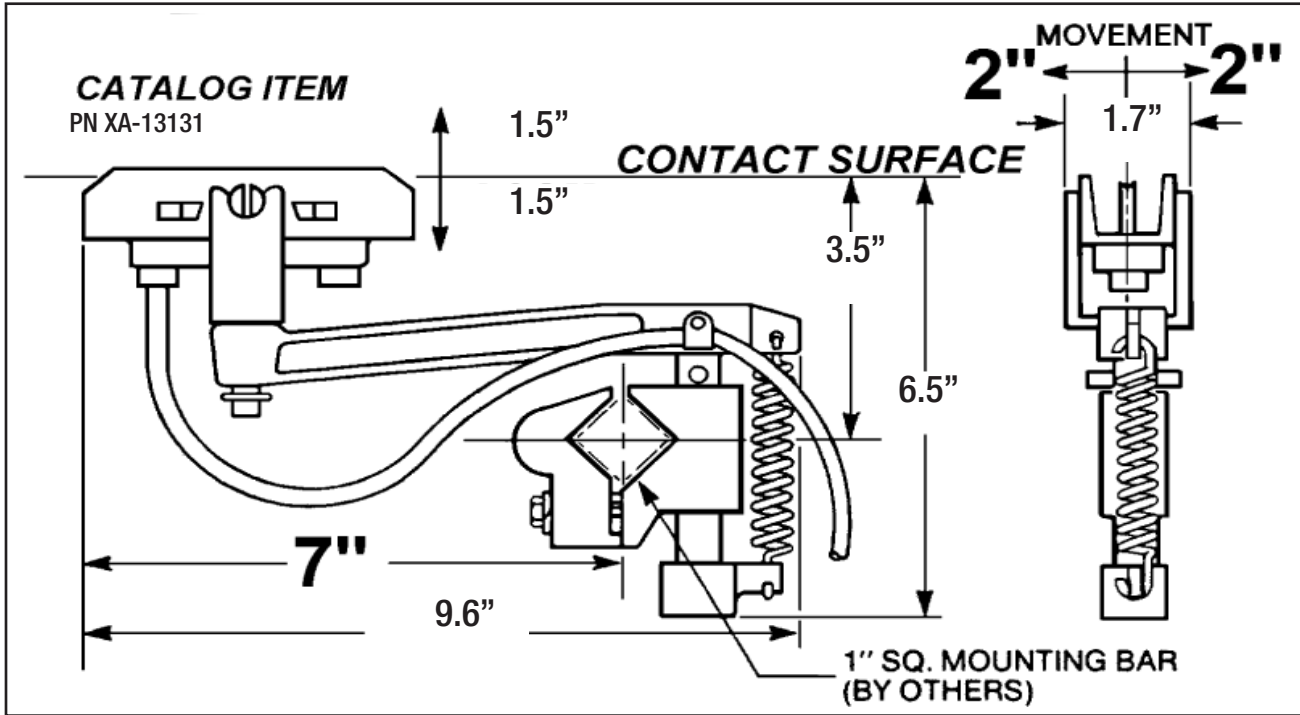

Figure 18-1

## SECTION 6 - TYPICAL COLLECTOR MOUNTING

### "C" Base - Tandem Mount

#### NOTE

- Torque mounting hardware to 8 - 10 ft lbs.

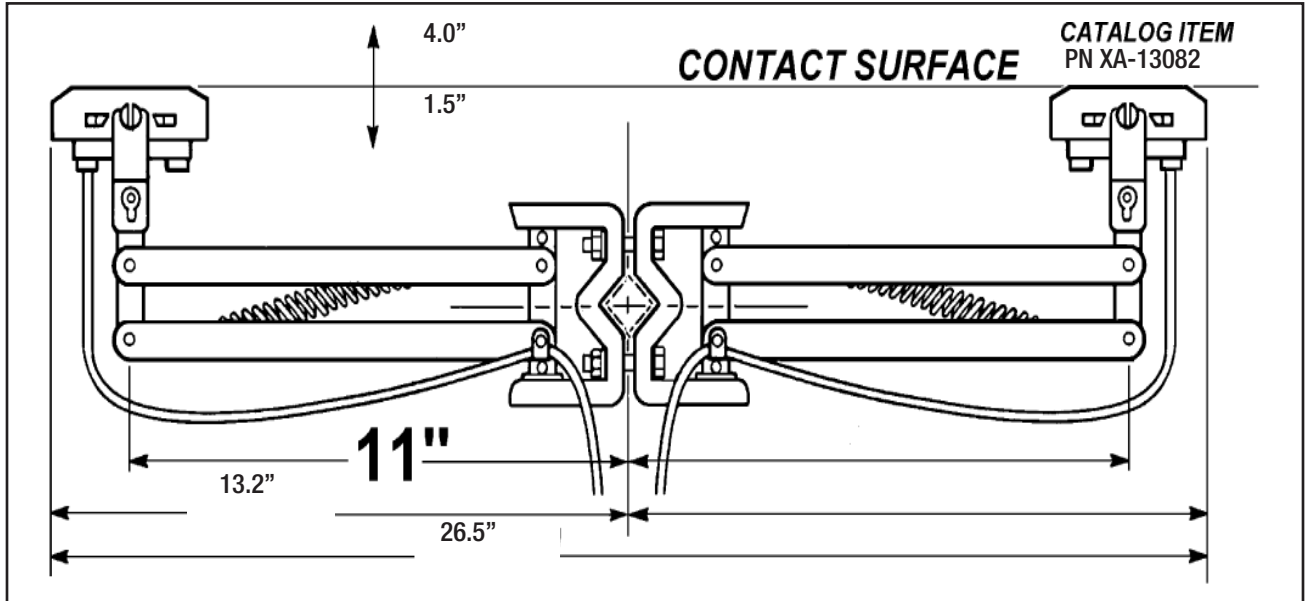

Figure 19-1

# SECTION 7 - EXPANSION GAP & ANCHORING REQUIREMENTS

## Installation of Expansion Sections

### Installation Overview

Expansion sections are installed in the same manner as standard 10' sections of conductor bar.

Expansion sections are shipped with 2 guide bracket clamps secured anchor tight and the other 2 guide bracket clamps at sliding tight.

### NOTE

- The anchor tight side is the side with the pin installed at the end of the bar. See **Figure 20-1**.

**Expansion Gap Settings Table**

Ambient Temp Range (°F)	0°-100°F					20°-120°F					40°-140°F				
Ambient Temp (°F)	0	25	50	75	100	20	45	70	95	120	40	65	90	115	140
Gap Setting (in)	2.25	1.75	1.25	.75	.25	2.25	1.75	1.25	.75	.25	2.25	1.75	1.25	.75	.25

Table 20-1

1. After installation, set the expansion gap. See **Table 20-1**.
2. Tighten the two sliding tight guide bracket clamps to anchor tight.

### NOTE

- The ones to be tightened are on the side without the pin at the end of the conductor bar.

3. Proceed with installation of the remaining conductor bars.

### NOTE

- After all conductor bars have been installed, loosen the 2 clamp bolts on side of guide bracket which was tightened to anchor tight (as done in step 2) on all expansion sections to sliding tight.
- Recheck the expansion gap after installation and adjust if necessary.

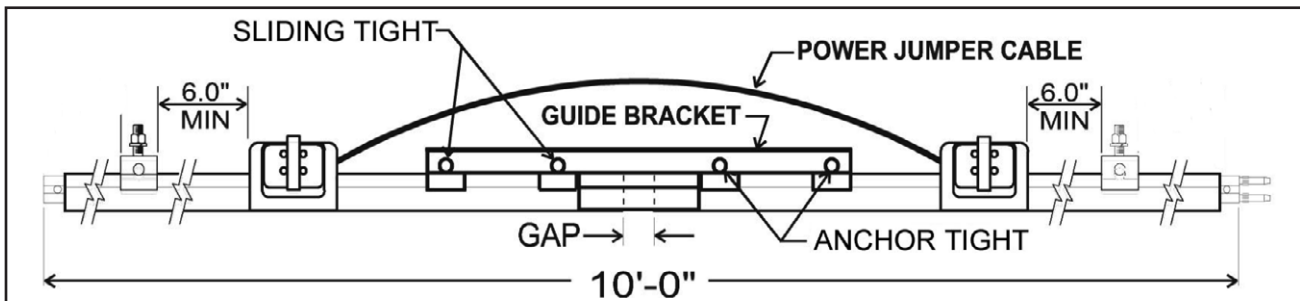

Figure 20-1

# SECTION 7 - EXPANSION GAP & ANCHORING REQUIREMENTS

## Expansion & Anchor Location Diagram

Location of expansion sections is critical for proper functioning of the system.

Follow installation drawing or, if no drawing is available, see **Figure 21-1**.

## Anchors

Anchor points are required at midpoint on all systems without expansion sections. For systems with expansion sections, anchors are required midpoint between expansions and between the first and last expansions and the ends of the run. See **Figure 21-1**.

Cross-Bolt hangers can be used as anchors on systems without expansion sections. On systems with expansion sections it is recommended that anchor clamps be used. Proper torque for anchor clamp cross bolts is 12-14 ft-lbs. See **Figure 21-2**.

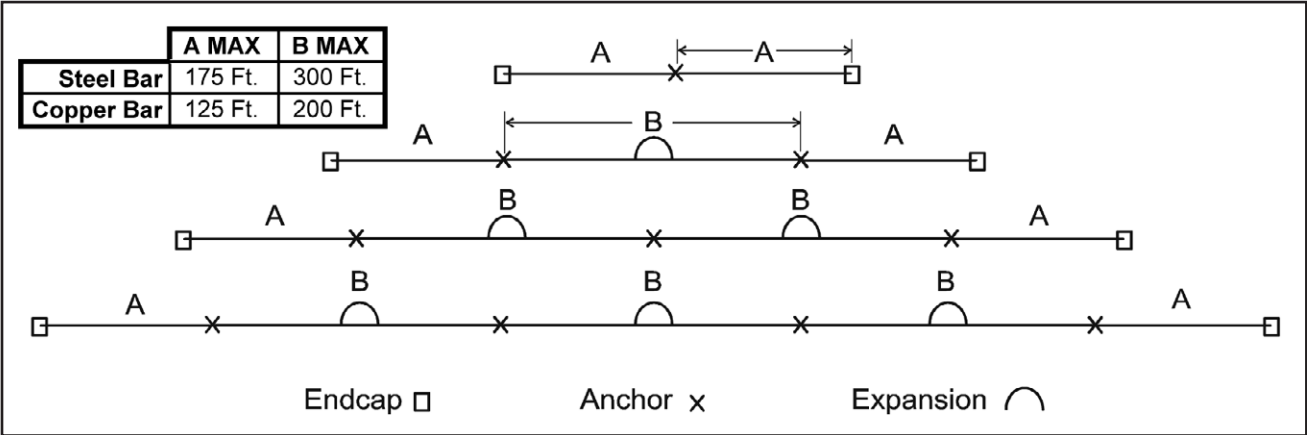

Figure 21-1

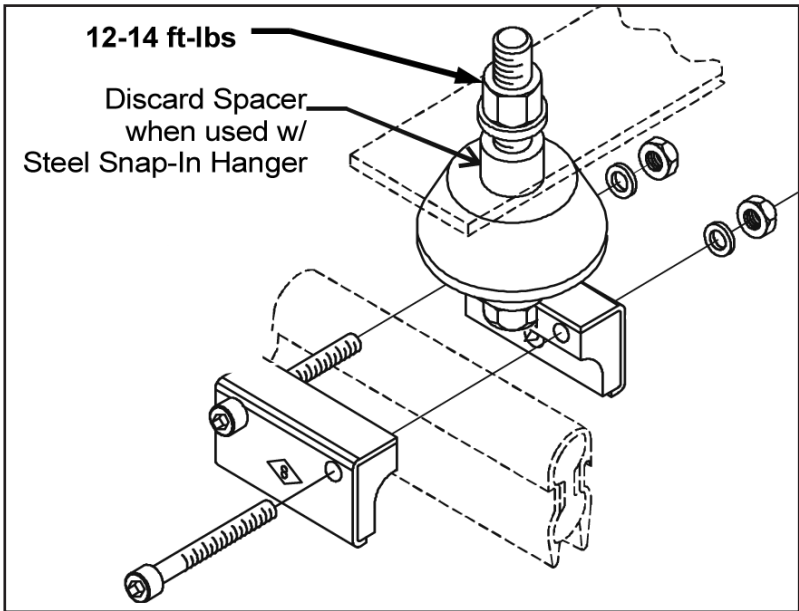

Figure 21-2

## SECTION 8 - INSTALLATION PROCEDURE

1. Install hanger and anchor clamps as required. See **Figure 22-1**.
2. Install conductor bar.
  - A. For steel snap-in hangers, torque mounting bolt to 12-14 ft. lbs. after installing all conductor bars. See **Figure 22-2**.
  - B. For plastic snap-in hangers, torque mounting bolt to 8 ft. lbs. after installing all conductor bars. See **Figure 22-3**.
  - C. For cross-bolt hangers, torque mounting bolt to 12-14 ft. lbs. after installing all conductor bars. See **Figure 22-4**. See **Table 22-1** for cross-bolt torque specs.

Cross-Bolt Torque Specs		
Hanger Material	Part No.	Anchor Tight
Plated Steel	XA-11076	4.0 - 5.0 ft-lbs
Stainless Steel	XA-11078	3.0 - 4.0 ft-lbs

**Table 22-1**

- D. Tighten until .02-.05 inch clearance remains between the hanger clamp and the conductor bar.

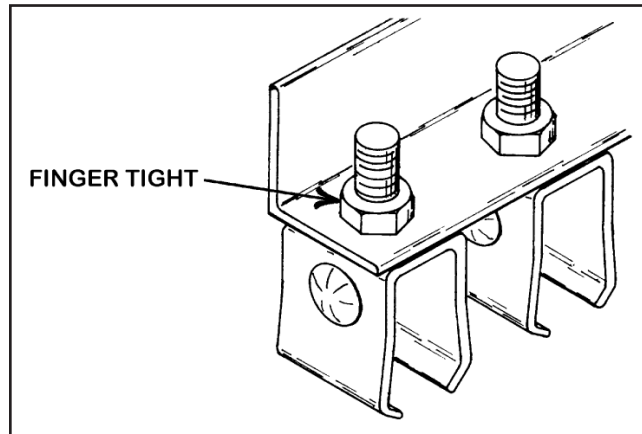

**Figure 22-1**

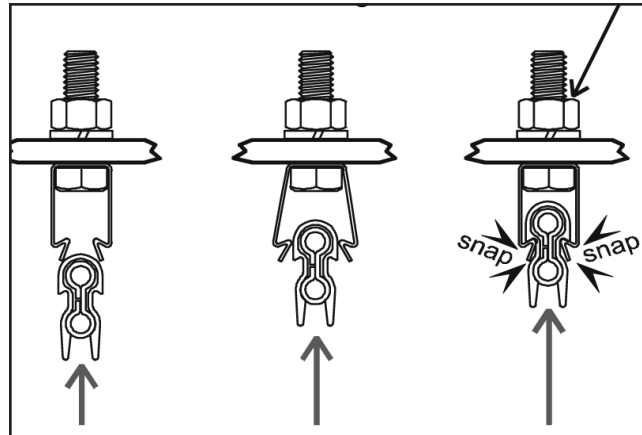

**Figure 22-2** Steel Snap-In Hangers

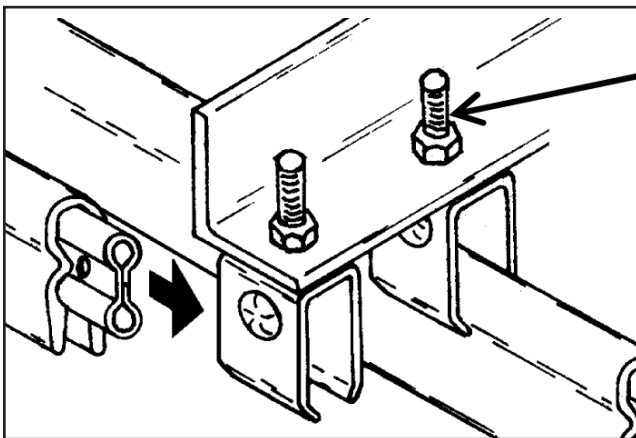

**Figure 22-4** Cross-Bolt Hangers

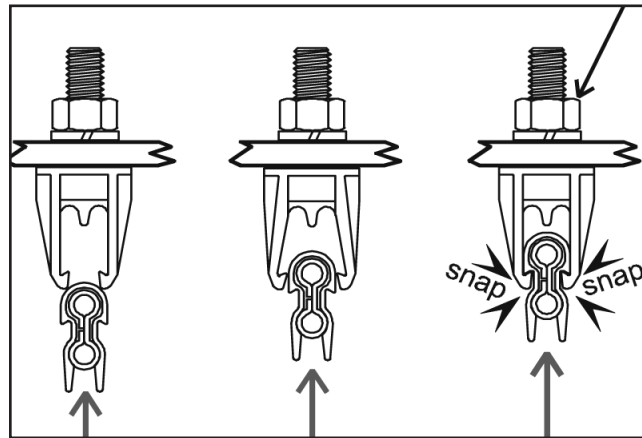

**Figure 22-3** Plastic Snap-In Hangers

## SECTION 8 - INSTALLATION PROCEDURE

3. Join conductor bar.
  - A. For joining pinned conductor bars, see **Figure 23-1**.
  - B. For joining bolted conductor bars, see **Figure 23-2**.

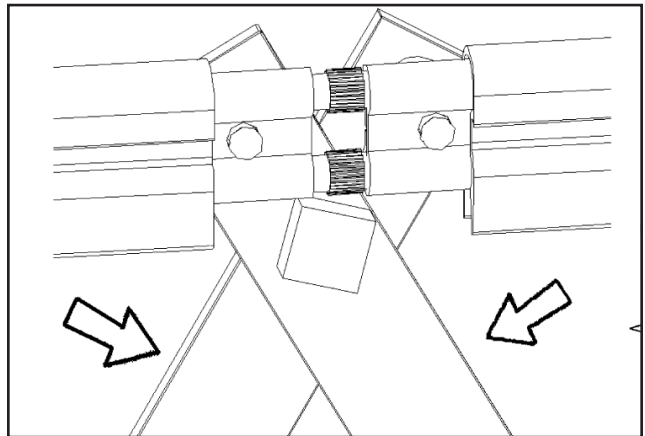

**Figure 23-1** Joining Pinned Conductors

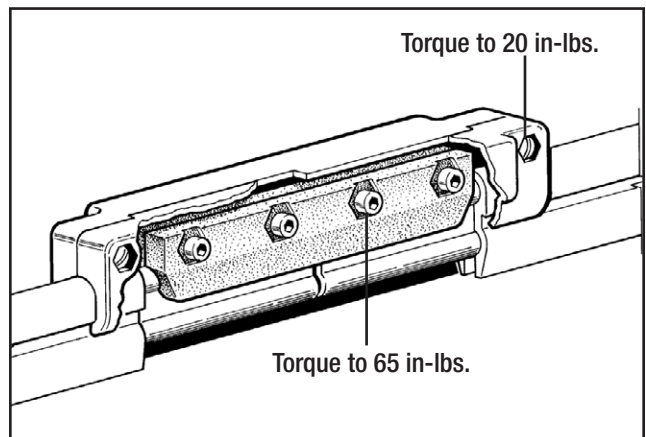

**Figure 23-2** Joining Bolted Conductors

## SECTION 8 - INSTALLATION PROCEDURE

4. Install joint keepers.

### NOTE

- Only copper bars require joint keepers.

A. Slide the long end of the joint keeper under the conductor bar cover on the smooth side of the bar. See **Figure 24-1**.

B. Push the pins into the holes of the bar. See **Figure 24-2**.

5. Install joint covers.

A. Snap joint cover over all 8-bar joints. See **Figure 24-3**.

B. For high heat joint cover (PN XA-11123), see **Figure 24-4**.

- a. Snap 4.5" cover over exposed conductor. Then snap on 6" cover and center it over the joint.
- b. Complete the joint cover by clamping both covers in place with the provided cross-bolt clamp.

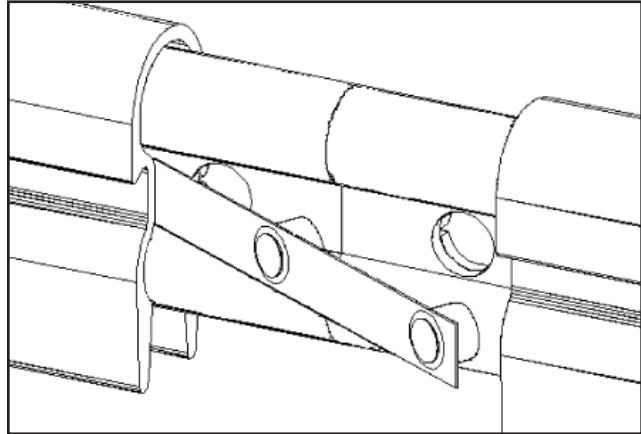

Figure 24-1

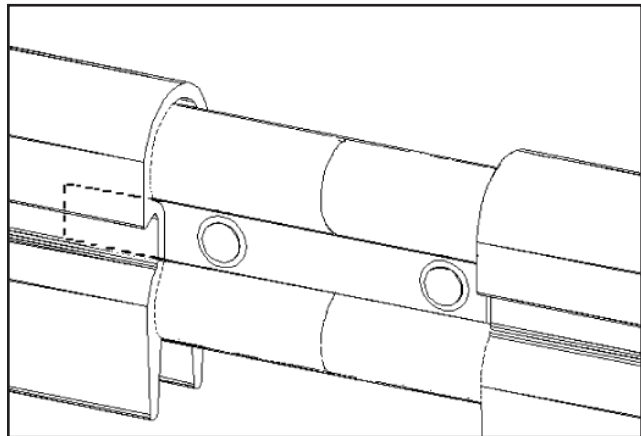

Figure 24-2

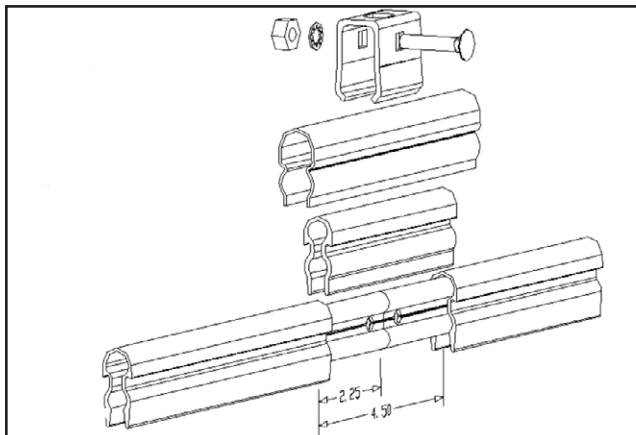

Figure 24-4

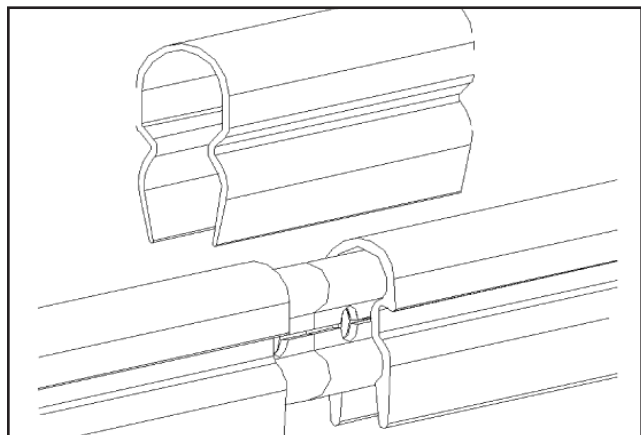

Figure 24-3



## SECTION 8 - INSTALLATION PROCEDURE

### 6. Install powerfeeds.

A. Install powerfeeds at locations shown on installation drawing. If no drawing was provided, locate powerfeeds following the designated space considerations as shown. See **Figure 25-1**.

B. Cut conductor bar cover as shown. See **Figure 25-1**.

### NOTE

- When using large cables, be sure that the customer supplied connector is attached to the clamp in such a manner that it does not interfere with the powerfeed case. See **Figure 25-2**.

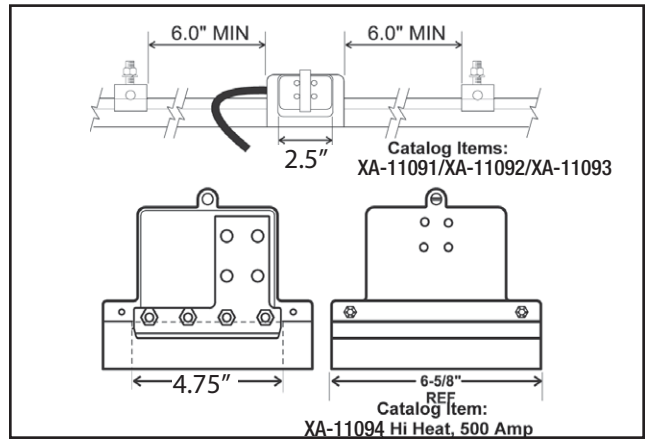

Figure 25-1

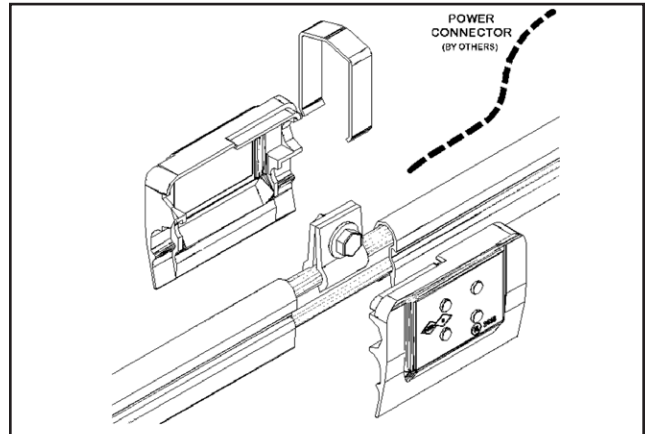

Figure 25-2

## SECTION 8 - INSTALLATION PROCEDURE

7. Install end covers / transfer caps.
  - A. Center end cover / transfer cap on the end of the bar. Tap lightly with a hammer until securely seated. See **Figure 26-1**.
8. Install collectors.
9. Conduct a final inspection.
  - A. Sight down the installed conductor runs and straighten any areas where conductor bar is out of alignment. Verify all mounting bolts on hangers are torqued to their proper values.
  - B. Make sure collectors are aligned properly with the conductor bar.
  - C. Check the distance between the center line of 1" square bar collector mounting staff and contact surface of conductor bar. Distance should be 3.5"
  - D. Make sure anchor clamps are properly positioned and anchor tight.
  - E. Make sure clamps on one side of expansion section have been made sliding tight. Verify that the expansion section air gap is correct for the ambient bar temperature.
  - F. Make sure all joint covers and, if applicable, all joint keepers are securely in place.
  - G. Check all electrical connections
  - H. Prior to introducing the system to service run the application at slow speed through the entire runway length in both directions to verify operation.

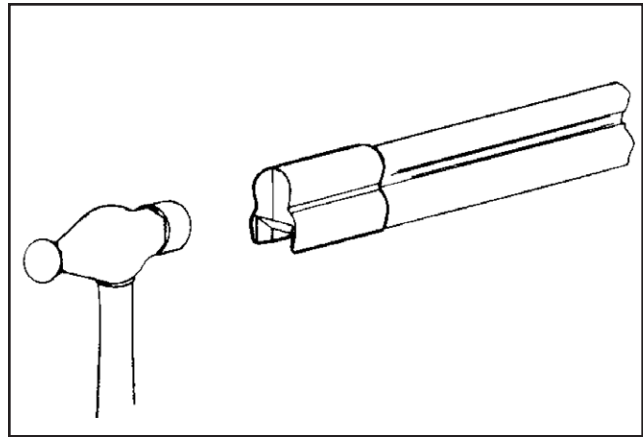

Figure 26-1

## SECTION 9 - SPECIAL APPLICATIONS

### Field Cutting

1. Cut conductor with a hack saw to desired length.
2. Cut cover:
  - PVC Cover: 0.75" shorter than conductor bar
  - Hi-Heat Cover: 2.25" shorter than conductor bar
3. Deburr/file field cut end as necessary.
4. Ream conductor lobes. See **Figure 27-1**.
  - 40, 110-350 Amp Bar: "D" Size Drill Bit
  - 90 Amp Bar: "M" Size Drill Bit
5. Install as usual.

### Curves

1. Install curved sections of conductor bar before any straight sections.
2. Maximum hanger spacing on curves is 3'.
3. Curves are generally anchored at the apex, at midway between the straight sections. Contact the factory with specific application questions for further information.
4. Minimum conductor bar spacing is 2" on curves, 3" recommended.
5. Cross bolt hanger clamps must be used on all curves.

### Discontinuous Systems

- Cross-bolt hanger clamps on pickup guide, assemblies are required to be anchor tight.

#### NOTE

- Pickup guides must be mounted on 2 hanger supports.
- Collectors should not be used to interrupt current.

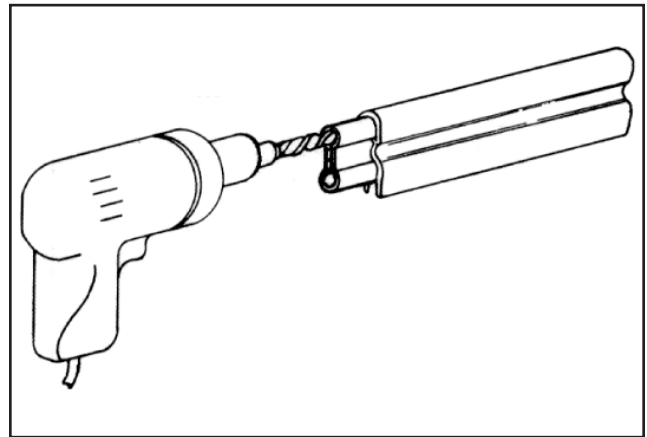

Figure 27-1

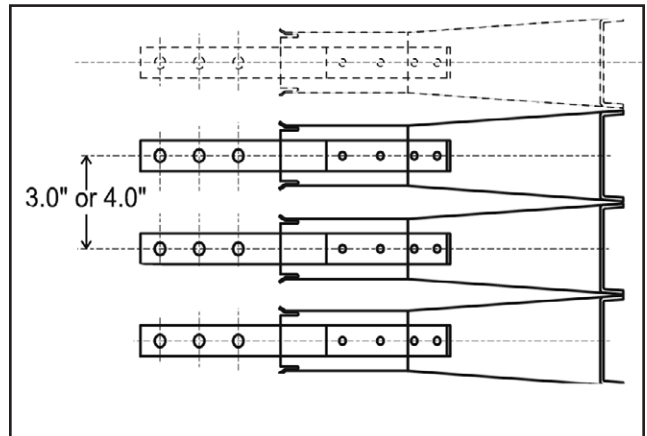

Figure 27-2

## SECTION 9 - SPECIAL APPLICATIONS

### Interlock, Switches, or Fixed Gaps

#### Switches

Cut of cover and position of transfer cap must be as shown. Hanger clamps to be anchor tight at "x". See **Figure 28-1**.

#### NOTE

- Switch sections over 25' may require an expansion section.

#### NOTE

- For laterally mounted systems, contact the factory 800-521-4888.

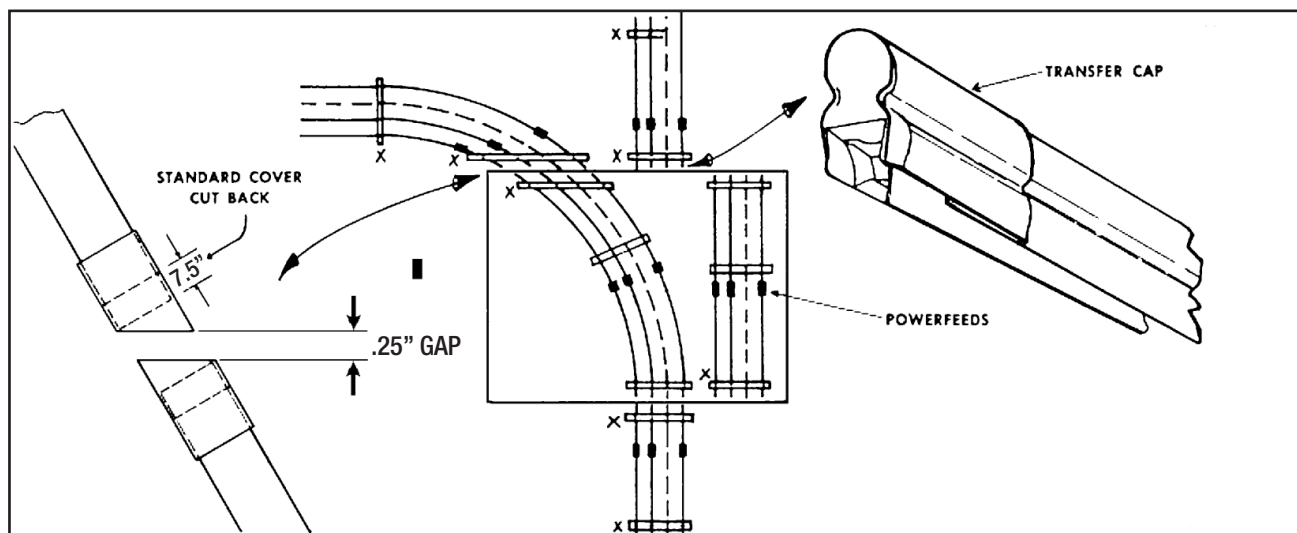

Figure 28-1

## SECTION 10 - TROUBLESHOOTING

8-Bar Conductor Troubleshooting		
Problem	Probable Cause	Solution
Burned joints or burned cover at joints	Loose joint, excess vibration, or over-tightened hanger clamps. Joint keeper not used.	Tighten joint, install joint keeper, check hanger clamps, and replace joint cover.
Distorted cover	Too high ambient temperature, under-rated bar.	Use high or medium heat cover. Check total current draw under worst conditions.
Pitted or burned conductor	Improper shoe pressure or worn out shoe.	Check collector mounting and spring pressure. Check for worn out shoe. If the above are corrected & condition persists, install tandem collectors.
Damaging environment	Acid fumes, salt air, extremely dirty atmosphere	May require copper or stainless steel conductor. Under these conditions conductor should always be mounted for vertical entry.

8-Bar Collector Troubleshooting		
Problem	Probable Cause	Solution
Shoes wear unevenly	Collector not mounted directly under conductor. Square bar is rotated out of position.	Remount or adjust collector
	Lead wire not slacked.	Loosen lead wire.
	Collector movement too tight	Free collector movement & lubricate
Shoes pitted and burned	Insufficient shoe pressure. Excessive bouncing or hand-pulled trolley not stable.	Check shoe pressure and mounting distance. Excessive bouncing can be reduced with tandem collectors. Install guide rollers and hand pulled trolleys. Also see: Pitted or burned conductor.
De-tracking	Distorted cover or joint cover.	Check condition and replace as necessary
	Misalignment at switches or crossovers	Re-align and re-anchor. Check switch movement
	Improperly installed.	Correct misalignment. Bad misalignment may require long arm collectors or expansion sections.
	Hanger clamp (cross-bolt type) too tight making bar "snake" to where collectors interfere with each other.	Loosen hangers so bar will slide. Tighten one hanger in center or between each expansion section.

## SECTION 11 - REPLACEMENT PARTS

The following is a suggested list of maintenance parts for use in the field:

- 1 extra set of contact shoes for each collector
- 1 extra spring for each collector
- 6 extra lengths of bar or 5% of total footage for average sized installations
- 1 clamp connector and cover for each extra length of bar where clamp replacement is desirable
- 3 complete collectors for 3 phase system, where use is severe

## CONDUCTIX-WAMPFLER FIELD SERVICE

### Need Field Service for our products? We Can Handle It!

Ask us for a quote on expert system installations, inspections, preventative maintenance, and repairs/retrofits.

As the world's largest single source manufacturer of mobile electrification products, Conductix-Wampfler has the unique ability to offer a degree of service not found anywhere else. Conductix-Wampfler's team of highly qualified service technicians and engineers have years of experience servicing our complete line of products.

We can provide:

- **Annual service contracts**
- **Installation**
- **Commissioning**
- **Installation supervision** to ensure your installers avoid common mistakes.
- **Troubleshooting** to get you up and running.
- **Pre-planned inspections** to complement your preventive maintenance program.

**Call 1.800.521.4888 for further details.**



# www.conductix.us

## USA / LATIN AMERICA

10102 F Street  
Omaha, NE 68127

Customer Support  
Phone +1-800-521-4888

Phone +1-402-339-9300  
Fax +1-402-339-9627

info.us@conductix.com  
latinamerica@conductix.com

## CANADA

18450 J.A. Bombardier  
Mirabel, QC J7J 0H5

Customer Support  
Phone +1-800-667-2487

Phone +1-450-565-9900  
Fax +1-450-851-8591

info.ca@conductix.com

## MÉXICO

Calle Treviño 983-C  
Zona Centro  
Apodaca, NL México 66600

Customer Support  
Phone (+52 81) 1090 9519  
(+52 81) 1090 9025  
(+52 81) 1090 9013

Fax (+52 81) 1090 9014

info.mx@conductix.com

## BRAZIL

Rua Luiz Pionti, 110  
Vila Progresso  
Itu, São Paulo, Brasil  
CEP: 13313-534

Customer Support  
Phone (+55 11) 4813 7330

Fax (+55 11) 4813 7357

info.br@conductix.com

Contact USA for our Global Sales Offices

