

# OPERATING, MAINTENANCE & PARTS MANUAL

## WIRE ROPE ELECTRIC HOISTS

# SERIES 80 Yale<sup>®</sup> HOISTS



Before installing hoist, fill in the information below.

Model Number \_\_\_\_\_

Serial No. \_\_\_\_\_

Purchase Date \_\_\_\_\_

Voltage \_\_\_\_\_

Rated Load \_\_\_\_\_

Please provide Serial Number when ordering parts.

### CAPACITIES: RATED LOADS 1/2 THRU 5 TONS

Follow all instructions and warnings for inspecting, maintaining and operating this hoist.

The use of any hoist presents some risk of personal injury or property damage. That risk is greatly increased if proper instructions and warnings are not followed. Before using this hoist, each operator should become thoroughly familiar with all warnings, instructions and recommendations in this manual. **Retain this manual for future reference and use.**

Forward this manual to operator. Failure to operate equipment as directed in manual may cause injury.

Columbus McKinnon Corporation  
205 Crosspoint Parkway  
Getzville, NY 14068

**WEIGHT WATCHER  
OVERLOAD CLUTCH  
MODELS RATED LOADS  
1/2 THRU 5 TONS**

**YALE HOIST PARTS AND SERVICES ARE AVAILABLE IN THE UNITED STATES AND IN CANADA**

As a YALE Hoist and Trolley user you are assured of reliable repair and parts services through a network of Master Parts Depots and Service Centers that are strategically located in the United States and Canada. These facilities have been selected on the basis of their demonstrated ability to handle all parts and repair requirements promptly and efficiently. To quickly obtain the name of the Master Parts Depot or Service Center located nearest you, call (800) 888-0985. Fax: (716) 689-5644.

# FOREWORD

This manual contains important information to help you install, operate, maintain and service your new YALE electric hoist. We recommend that you study its contents thoroughly before putting the hoist into use. We also recommend that you read ANSI B30.16 safety code and the applicable performance and safety standards referenced therein. Then, through proper installation, application of correct operating procedures, and by practicing the recommended maintenance procedures, you can expect maximum lifting service from the hoist.

It will likely be a long time before parts information found in the Parts List is needed. Therefore, after the hoist is installed and you have completely familiarized yourself with operation and preventative maintenance procedures, we suggest that this book be carefully filed for future reference.

When ordering replacement parts from this book, it will be necessary that you include with your order: the Hoist Serial Number and Model Number that are found on the nameplate attached to the hoist as shown in Figure 4-1. For your convenience, a space has been provided on the front cover of this Manual for entering this information. We recommend that you fill it out immediately so it is readily at hand when needed.

The contents of this manual are of necessity, general in nature and may cover features not incorporated on your hoist; or, you may have ordered features not covered by this manual. Therefore, the user must exercise care in applying instructions given in this manual. If specific information not in this manual is required, contact customer service.

**THE INFORMATION CONTAINED IN THIS MANUAL IS FOR INFORMATIONAL PURPOSES ONLY AND YALE DOES NOT WARRANT OR OTHERWISE GUARANTEE (IMPLIEDLY OR EXPRESSLY) ANYTHING OTHER THAN THE COMPONENTS THAT YALE MANUFACTURES AND ASSUMES NO LEGAL RESPONSIBILITY (INCLUDING, BUT NOT LIMITED TO CONSEQUENTIAL DAMAGES) FOR INFORMATION CONTAINED IN THIS MANUAL.**

## TABLE OF CONTENTS

Master Parts Depots And Service Centers .....	2	<b>TROUBLESHOOTING CHART .....</b>	<b>20</b>
Foreword .....	3		
<b>GENERAL DESCRIPTION</b>		<b>ADJUSTMENTS</b>	
General .....	4	Mechanical Load Brake .....	22
Basic Construction .....	4	Motor Brake .....	22
Differences Between Models .....	4	Block Operated Limit Switch .....	26
		Screw - Type Limit Switch .....	26
		Overload Clutch Adjustment .....	26
<b>INSTALLATION</b>		<b>WIRING DIAGRAMS .....</b>	
General .....	5		<b>27</b>
Suspending Hoist .....	5	<b>REPAIR PARTS LIST</b>	
Connecting Hoist to Electrical Service .....	5	General .....	28
Pre-Operation Checks .....	6		
<b>OPERATION</b>		<b>LIST OF ILLUSTRATIONS</b>	
General .....	7	<b>FIG.</b>	<b>DESCRIPTION</b>
Push Button Operation .....	7		<b>PAGE</b>
Overload Clutch Operation .....	7	9-1	Frame, Gearcase and External Parts .....
Operating Precautions .....	7	9-2	Gearing and Load Brake Parts .....
Safety Precautions .....	2	9-3	Hoist Motor Brake .....
		9-4	Three Phase Motor Assembly .....
		9-5	Upper Limit Switch Parts .....
		9-6	Electrical Control Equipment .....
		9-7	Push Button Station Assembly and Conductor Cable (Single Speed) .....
		9-8	Push Button Station Assembly and Conductor Cable (Two Speed) .....
		9-9	Lower Block Assembly — 2 parts rope, single reeved .....
		9-10	Lower Block Assembly — 2 part double reeved .....
		9-11	Upper and Lower Block Parts (3 & 5 Ton) .....
		9-12	Screw-Type Limit Switch Parts .....
<b>LUBRICATION</b>			
General .....	9		
Change Gearcase Oil .....	9		
Lubricate Hoist Cable .....	9		
Lubricate Upper Sheave & Lower Block Assembly .....	9		
Lubricate Limit Stop Lever .....	9		
Lubricate Limit Switch .....	9		
<b>INSPECTION AND PREVENTATIVE MAINTENANCE</b>			
General .....	10		
Inspect Lower Block .....	10		
Inspect Upper Block and Hoist Suspension .....	11		
Inspect Electrical Controls .....	11		
Inspect Motor Brake .....	13		
Inspect Mechanical Load Brake, Gearing and Overload Clutch (Optional) .....	13		
Inspect Rope Drum and Shaft .....	15		
Rope Inspection, Maintenance and Replacement .....	15		
Rope Reeving .....	16		
Testing Hoist and Overload Clutch (Optional) .....	18		

No part of this document may be reproduced in any form, in an electronic retrieval system or otherwise, without prior written permission of the publisher.

# GENERAL DESCRIPTION

## GENERAL

YALE electric hoists are precision built wire rope and drum type hoists which are made in five rated load sizes (1/2, 1, 2, 3 and 5 tons) with various lifts, lifting speeds and electrical service. Equipped with an integrally welded mounting lug, they are designed to be rigidly attached to an overhead structure or mounted on YALE rigid mount trolleys for operation on runway beams. On certain models optional base mounting or other supporting methods may be obtained. For more information, please contact the Customer Service team.

**NOTICE: YALE hoists are available with an optional built-in mechanical overload clutch. Hoists having this device are identified with words WEIGHT WATCHER on the hoist.**

The WEIGHT WATCHER overload clutch permits operation of your hoist within its rated load and helps prevent lifting of excessive loads which could cause permanent deformation of a properly maintained hoist or trolley.

## BASIC CONSTRUCTION

All models are of the same basic construction and consist of a rugged welded steel frame which houses a lifting drum and serves as the suspension for carrying the entire hoist load. A mounting lug, for attaching the hoist to a trolley or overhead support, is located on top of the frame. An aluminum alloy gearcase and cover, attached to one end of frame, houses a three-reduction gear train and a mechanical load brake. An electric driving motor with disc-type motor brake is located beside the frame, face mounted on the back of the gearcase. Electrical system components, located on the end of the frame (opposite gearcase end) and enclosed by a steel cover, control operation and rotating direction of a driving motor. A hoisting rope and an enclosed lower block assembly are used for lifting loads. An upper limit stop is used to limit travel of the lower block in the raising direction, to protect hoist from damage. A push button control station, for operating the hoist, is suspended from the electrical compartment.

## DIFFERENCES BETWEEN MODELS

The main differences between models are in rope reeving and frame size as described below.

- a. **Rope Reeving.** There are four types of rope reeving used:  
Two parts of rope single reeved, four parts of rope single reeved, six parts of rope single reeved and two parts of rope double reeved. Single reeved hoists have one end of the rope anchored to the drum, whereas, double reeved hoists have both ends anchored to the drum. On single reeved models, the lower block travels sideways as rope winds on drum, double reeved models offer true vertical lift. For illustrations, refer to Section V, paragraph 5-9, "Rope Reeving" instructions.
- b. **Frame Size.** Length of frame furnished is dependent on hoist capacity and lift. Four frame lengths are used; short frame, long frame, first and second extensions. Short frame hoists have a rope drum flange to flange distance of approximately 9-3/4", whereas this distance on a long frame hoist is approximately 16-3/4". First extension frame hoists have a flange to flange distance of 22-15/16" and second extensions have 35-3/8".
- c. **Motor Brake.** Hoists are equipped with a disc brake mounted on the motor end bell and operated by a short stroke solenoid. This brake requires periodic adjustment.

# INSTALLATION

## GENERAL

YALE electric hoists are lubricated and tested before being shipped from the factory. To place hoist in service, attach to a suitable suspension (paragraph 2-2), connect to electrical service (paragraph 2-3) and perform pre-operation tests and checks (paragraph 2-4).

### **⚠ WARNING**

Before attempting installation of hoist or trolley, the main power switch must be locked in the open position (off).

## SUSPENDING HOIST

The hoist may be suspended in a fixed location servicing only the area directly below the hoist (Lug Mounted) or the hoist may be attached to a moveable trolley or trolleys which in turn may be mounted on an I-beam attached to a building or crane, servicing a larger area (Trolley Mounted).

### **⚠ WARNING**

DO NOT use small holes for attaching this hoist unless rated load on lower block is 1 (one) ton (2000 lbs.) or less.

- a. **Lug Mounted** hoists attach to adequate supports welded or bolted to a building or other structure. The supporting structure must have sufficient strength with appropriate safety factor, to support the weight of the hoist and rated load as well as other loads to which the supporting structure may be subjected.

### **⚠ WARNING**

Design and installation of hoist support shall be performed only by qualified persons.

Steel angles or plates used to suspend hoist should be spaced as close to the hoist suspension lug as possible. Mounting bolts or threaded studs, attaching hoist to mounting structure, shall have a diameter not less than recommended by manufacturer and material equivalent to ASTM A 325. Make certain that mounting bolts or studs are long enough so that the threads do not engage the mounting support and that mounting bolts or studs are secured with nuts and lockwashers, self-locking nuts or cross bolting, if unthreaded.

- b. **Trolley Mounted** hoists are attached to moveable trolleys. If the hoist is mounted on an existing trolley, a qualified person shall determine that the trolley and its supporting structure are adequate to support the rated load and weight of the hoist. Hoist/trolley units may be shipped from the factory with trolley packaged separately. If the trolley can be installed directly over the end of the supporting beam, assemble trolley to hoist. Be certain that the spacing between wheel flanges, after assembly, is 1/4" greater than exact width of beam flange. (See Figure 2-1 below and instruction sheet furnished with trolley.) Using proper equipment, carefully lift trolley and hoist and install on end of beam.

For trolleys which are to be mounted along the span of a beam not having open ends, measure exact width of beam flange and assemble trolley to hoist so that spacing between wheel flanges is 1/4" (see Figure 2-1) greater than beam width (3/8" if beam has curves). This is accomplished by rearranging the spacer washers on the bolts connecting trolley side plates to hoist mounting lug. If trolley is shipped separate from hoist, see instruction sheets furnished with trolley for orientation and installation.

When proper spacing has been determined, loosen mounting nuts (item 1, Figure 2-1) to allow trolley wheels to spread far enough to pass over edges of beam flange. (Some installations may require complete removal of one trolley side plate.) Using adequate equipment, carefully lift the hoist and

trolley so the wheel treads will rest on the lower beam flange. Replace side plate and washers if removed for installation. Replace suspension stud nuts.

### **⚠ CAUTION**

Recheck spacer washers to make certain that the number of washers between the side plate and hoist suspension lug are equal, and also the number on the outside of each side plate are equal. The suspension stud nuts should only be snugged up on the lockwashers until a load has been applied on the hook. A partial load (approx. 25% rated hoist load) placed on the hook will properly seat hoist in the trolley. Tighten suspension stud nuts only after hoist has been properly seated in the trolley.

### **⚠ WARNING**

Mounting of the hoist/trolley unit on the monorail and final pre-operation inspection shall be performed only by qualified persons properly supervised.

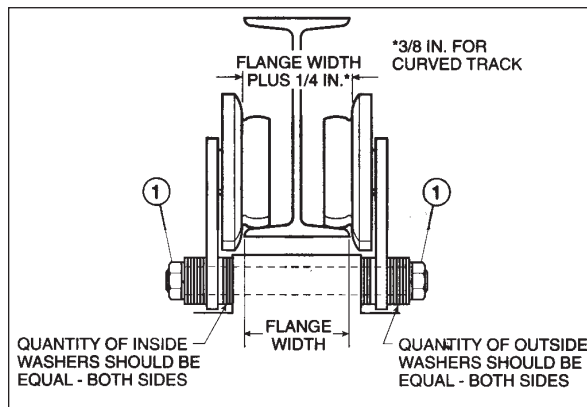

Figure 2-1. Sectional View of Trolley showing proper wheel and washer spacing

## CONNECTING HOIST TO ELECTRICAL SERVICE

Electrical service to the hoist may be power cable or a guarded system having sliding shoe collectors.

### **⚠ WARNING**

Be certain that electrical power supply is OFF and locked in the open position before attempting any electrical connections to the hoist. This equipment must be effectively grounded according to the National Electric Code, or other applicable codes. A separate grounding conductor shall be provided.

- a. Follow National, State and Local Electrical Codes when providing electrical service to the hoist.

### **⚠ CAUTION**

230/460V single speed motors are reconnectable at the motor. See motor nameplate. Transformer may be reconnected for 200/230/460/575V. See transformer. Check with wiring diagram to make certain that motor, transformer and brake leads are properly connected.

- b. Make electrical connections using the appropriate wiring diagrams furnished with the hoist. All electrical **connections**, including connections to collectors or power cord, **shall be made only by qualified journeymen electricians.**

### **⚠ WARNING**

The green wire provided in the power supply cable (when furnished) is a grounding wire and must be connected to a proper ground.

- c. When trolley is shipped separate from hoist, see special instructions furnished with trolley for orientation and installation.

## PRE-OPERATION CHECKS

- a. **Check Oil Level and Grease Fittings.** The gearcase has been filled with oil to the proper level and grease points for lower and upper sheaves have been lubricated at the factory. However, this should be checked before operating hoist. Check oil level by removing oil level plug with hoist in a level position. Oil level should be at the bottom edge of the plug hole. If not, add oil as specified in Section IV. Grease fittings in lower and upper sheave pins should show evidence of grease.

### CAUTION

Overfilling of the gearcase may result in the excess fluid being expelled through the breather.

- b. **Check Push Button Operation and Phasing:**

### WARNING

On three phase hoists it is possible to have "Reverse Phasing" causing the lower block to lower when the ↑ button is depressed. When this condition exists, the automatic limit stop switch is inoperative and hoist operation will be dangerous.

To properly check the phase of the hoist, follow steps below:

1. With "POWER OFF" operate all the push buttons and determine that they do not bind or stick in any position.

### WARNING

If any push button binds or sticks in any position - DO NOT TURN POWER ON - determine the cause and correct the malfunction before operating.

2. Temporarily connect hoist to power source.
3. Operate ↑ button briefly to determine direction of hook travel.
4. If hook raises, phase is correct. Turn power off and make temporary connections permanent.
5. If hook lowers, hoist is "Reverse Phased." TURN POWER OFF and correct by interchanging any two leads at **power source** connection. Do not change internal wiring of hoist.

- c. **Check Limit Switch Operation.**

1. A block operated upper limit stop (Figure 2-2) is furnished as standard equipment. This limit stop is factory set to stop lower block in its high position and guard against over-travel and possible damage to hoist. (Note mounting position of floating lever for 3 and 5 ton hoists.) No adjustment can be made. Limit switch operation should be tested when hoist is installed. Move hook to a low position by depressing push button marked ↓. Now depress button marked ↑ to raise hook. While hook is traveling upward, manually (or with an extension pole) raise limit stop mechanism (Figure 2-2).

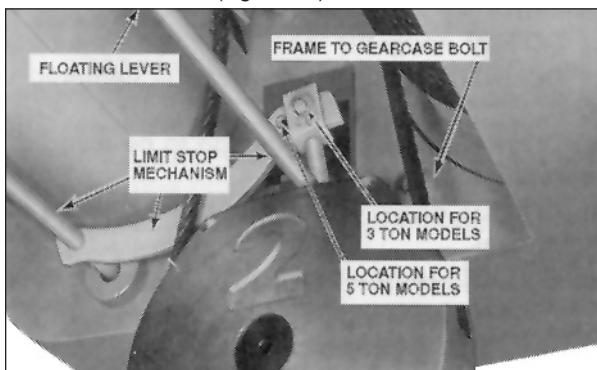

Figure 2-2. Limit Stop Mechanism Being Tripped By Lower Block

When floating rod is raised, stop switch is actuated first and then the reversing switch is actuated (Figure 2-3). Stop switch stops hoist. Reversing switch lowers hook block in case of floating rod over-travel. If limit switch does not function in this manner, refer to trouble shooting chart Section VI for possible remedy.

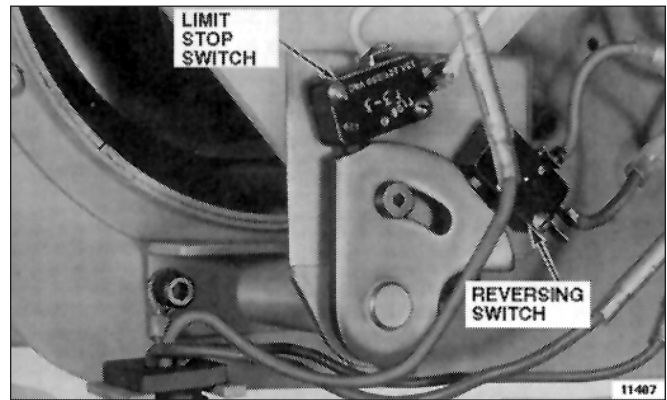

Figure 2-3. Electrical Compartment Cover Removed Showing Limit Switch and Reversing Switch Arrangement

2. A screw-type upper and lower limit switch is provided optionally when both upper and lower limit stops are required (Figure 7-2). This switch is adjustable and must be adjusted, at time hoist is installed, to desired high and low limits of lower block travel. Refer to Section VII.
- d. **Check Lower Block and Hoisting Cable.** Depress ↓ push button and run lower block to its lowest position. **No less than two wraps shall remain on the drum with the loaded hook in its lowest position, unless hoist is equipped with a lower limit switch in which case no less than one and one half wraps shall remain on the drum.** Also check to see that lower block and rope does not twist excessively. If it does twist to the extent that two ropes rub against each other, disengage rope from the frame anchor and twist rope four or five turns in a direction opposite to that which the block turns. Reconnect rope to anchor (Figure 2-4), holding firmly to eliminate rope twisting back to its original position. Operate hoist up and down a few times. If lower block still rotates, repeat process until twisting is corrected.
  - e. **Lubricate Hoisting Cable.** For longer cable life, it is recommended that the cable be lubricated at time of installation by applying a Chain and Cable Fluid as outlined in Section IV, paragraph 4-3.

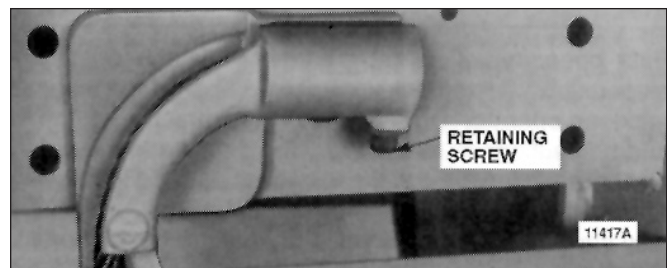

Figure 2-4. Rope End Anchor

# OPERATION

## GENERAL

Operation of Series Y80 YALE electric hoists is controlled by a convenient pendant push button station. With it, the hoist can be controlled to give fast lifting and lowering; or controlled to lift or lower load in small increments, providing accurate spotting. The pushbutton station has a built-in interlock to prevent depressing opposing buttons simultaneously.

When first using hoist, break-in by operating under lighter loads to full travel before applying maximum load.

## PUSH BUTTON OPERATION

- a. Depress push button marked ↑ to raise load.
- b. Depress push button marked ↓ to lower load.
- c. Jogging the push button will give “hairline” load movement. The quickness of the depressing motion will determine the amount of movement. **Excessive use of this “Jogging” feature will cause premature burning of contact tips and motor overheating.**
- d. On two-speed hoists, partial depression of button operates hoist at slow speed; depressing button completely operates hoist at fast speed.

## OVERLOAD CLUTCH OPERATION (OPTIONAL)

The overload clutch, when furnished with the hoist, is factory preset and tested so that the hoist will lift its full rated load but will refuse to lift overloads which could cause deformation or weakening of your hoist. If the load to be lifted exceeds the clutch setting, the hoist motor will continue to run when the ↑ button is depressed and rotate the load brake gear without lifting the load. Whenever this slipping occurs, immediately release the ↑ button to prevent overheating of the clutch friction surfaces and the hoist motor.

**NOTICE: Always know load to be lifted. Lift-Tech does not recommend lifting loads greater than the rated capacity of your hoist.**

## OPERATING PRECAUTIONS

### **WARNING**

Equipment covered herein is not designed or suitable as a power source for lifting or lowering persons.

Safe operation of an overhead hoist is the operator’s responsibility. Listed below are some basic rules that can make an operator aware of dangerous practices to avoid and precautions to take for his own safety and the safety of others. Observance of these rules in addition to frequent examinations and periodic inspection of the equipment may save injury to personnel and damage to equipment.

- a. DO read ANSI B30.16 Safety Standard for Overhead Hoists and the Operation, Service and Parts Manual.
- b. DO be familiar with hoist operating controls, procedures and warnings.
- c. DO make sure hook travel is in the same direction as shown on controls.
- d. DO make sure hoist limit switches function properly.
- e. DO maintain firm footing when operating a hoist.
- f. DO make sure that load slings or other approved single attachments are properly sized and seated in the hook saddle.
- g. DO make sure that the hook latch is closed and not supporting any part of the load.
- h. DO make sure that load is free to move and will clear all obstructions.
- i. DO take up slack carefully, check load balance, lift a few inches and check load holding action before continuing.
- j. DO avoid swinging of load or load hook.
- k. DO make sure that all persons stay clear of the suspended load.

- l. DO warn personnel of an approaching load.
- m. DO protect wire rope from weld splatter or other damaging contaminants.
- n. DO promptly report any malfunction, unusual performance, or damage of the hoist.
- o. DO inspect hoist regularly, replace damaged or worn parts, and keep appropriate records of maintenance.
- p. DO use the hoist manufacturer’s recommended parts when repairing a hoist.
- q. DO use hook latches.
- r. DO apply lubricant to wire rope as recommended.
- s. DO NOT lift more than rated load.
- t. DO NOT use a damaged hoist or a hoist that is not working correctly.
- u. DO NOT use the hoist with twisted, kinked, damaged or worn wire rope.
- v. DO NOT lift a load unless wire rope is properly seated in its drum groove(s).
- w. DO NOT use wire rope as a sling or wrap rope around the load.
- x. DO NOT lift a load if any binding prevents equal loading on all supporting ropes.
- y. DO NOT apply the load to the tip of the hook.
- z. DO NOT operate unless load is centered under hoist.
- aa. DO NOT allow your attention to be diverted from operating the hoist.
- ab. DO NOT operate the hoist beyond limits of wire rope travel.
- ac. DO NOT use limit switches as routine operating stops unless recommended. They are emergency devices only.
- ad. DO NOT use hoist to lift, support or transport people.
- ae. DO NOT lift loads over people.
- af. DO NOT leave a suspended load unattended unless specific precautions have been taken.
- ag. DO NOT allow sharp contact between two hoists or between hoist and obstructions.
- ah. DO NOT allow the rope or hook to be used as a ground for welding.
- ai. DO NOT allow the rope or hook to be touched by a live welding electrode.
- aj. DO NOT remove or obscure the warnings on the hoist.
- ak. DO NOT adjust or repair a hoist unless qualified to perform hoist maintenance.
- al. DO NOT attempt to lengthen the wire rope or repair damaged wire rope.
- am. DO NOT allow personnel not physically fit or properly qualified to operate hoist.
- an. DO NOT operate hoist unless limit switch is operating properly.
- ao. DO be sure there is no twist in wire rope.
- ap. DO avoid operating hoist when hook is not centered under hoist. Avoid side pulls and swinging of load or load hook when traveling hoist.

### **WARNING**

DO NOT operate hoist with the hoisting rope out of the drum grooves. Such operation may result in the rope breaking and dropping the load which can cause damage to equipment and injury to operator or other personnel. Hoist rope will remain in the drum grooves during operation under normal operating conditions, however, slack or kinked rope, excessive side pulls, swinging or jerking of load, or similar abuse, may cause the rope to leave the grooves.

- aq. DO operate hoist within recommended duty cycle and do not “jog” unnecessarily.
- ar. DO conduct regular visual inspections for signs of damage or wear.
- as. DO NOT operate hoist with hooks that have opened up. See Figure 5-1.
- at. DO provide supporting structure or anchoring means that has a load rating at least equal to that of the hoist.
- au. DO NOT use hoists in locations that will not allow operator movement to be free of the load.
- av. DO, when starting to lift or pull, move the load a few inches at which time the hoist should be checked for proper load holding action. The operation shall be continued only after the operator is assured that the hoist is operating properly.
- aw. DO NOT leave a loaded hoist unattended at the end of a work shift or for extended periods during the work shift. Where operations are such that this condition cannot be avoided the operator must be assured that the condition does not create a hazard to personnel or property.
- ax. DO NOT use the hoist load limiting device to measure the load.
- ay. DO NOT operate hoist unless hook moves in the same direction as indicated on the pushbutton. If opposite direction occurs, see pre-operation checks, Paragraph 2-4.b.
- az. Observe recommended inspection and maintenance procedures.
- ba. DO use common sense and best judgement whenever operating a hoist. Observe American National Standard Safety standard, ANSI B30.16, latest issue.

## **SAFETY PRECAUTIONS**

Each YALE Wire Rope Hoist is built in accordance with the specifications contained herein and at the time of manufacture complies with our interpretation of applicable sections of \*American Society of Mechanical Engineers Code (ASME) B30.16 “Overhead Hoists,” the National Electrical Code (ANSI/NFPA 70) and the Occupational Safety and Health Act (OSHA). Since OSHA states the National Electrical Code applies to all electric hoists, installers are required to provide current overload protection and grounding on the branch circuit section in keeping with the code. Check each installation for compliance with the application, operation and maintenance sections of these articles.

The safety laws for elevators, lifting of people and for dumbwaiters specify construction details that are not incorporated into the hoists. For such applications, refer to the requirements of applicable state and local codes, and the American National Safety Code for elevators, dumbwaiters, escalators and moving walks (ASME A17.1). Columbus McKinnon Corporation cannot be responsible for applications other than those for which YALE equipment is intended.

\*Copies of this standard can be obtained from ASME Order Department, 22 Law Drive, PO Box 2300, Fairfield, NJ 07007- 2300, U.S.A., [www.asme.org](http://www.asme.org), 800-843-2763.



**THIS SYMBOL POINTS OUT IMPORTANT SAFETY INSTRUCTIONS WHICH IF NOT FOLLOWED COULD ENDANGER THE PERSONAL SAFETY AND/OR PROPERTY OF YOURSELF AND OTHERS. READ AND FOLLOW ALL INSTRUCTIONS IN THIS MANUAL AND ANY PROVIDED WITH THE EQUIPMENT BEFORE ATTEMPTING TO OPERATE YOUR YALE HOIST.**



## LUBRICATION

### GENERAL

The lubrication services outlined in paragraphs 4-2 through 4-6 should be performed at regular intervals to maintain top hoist performance and ensure long life. Intervals of at least six (6) months, coinciding with spring and fall seasons, are recommended. The reason for this is, on hoists installed out-of-doors and in unheated areas, a "cold test" lubricant is required in cold (below freezing) climates making seasonal changes necessary.

### CHANGE GEARCASE OIL (FIGURE 4-1)

- a. Remove oil drain plug from bottom of gearcase and drain out oil. (Two drain plugs, one on front and one on back of gearcase.)
- b. Flush out hoisting using petroleum solvent. Reinstall drain plug.
- c. Refill through oil hole cover to proper level (bottom of oil level plug hole) using 10 pints of Automatic Transmission Fluid, DEXRON III Type, suitable for all temperature ranges.

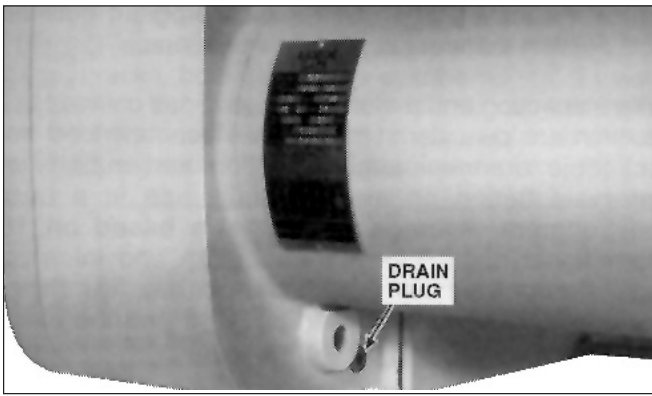

Figure 4-1. View Showing Location of One Oil Drain Plug

### LUBRICATE HOISTING CABLE

are shipped from the factory without an exterior coating on hoisting cable. It is recommended, where conditions permit, that the cable be thoroughly coated at installation and kept well lubricated with LUBRIPLATE Chain and Cable Fluid, or equal, suitable for all temperature ranges.

### LUBRICATE UPPER SHEAVE AND LOWER BLOCK ASSEMBLY

- a. All hoists have grease fittings located in ends of sheave pins. Apply (\*) NLGI No. 2 grease for operating temperatures from +50°F to +125°F. For colder temperatures, (-20°F to +50°F) use NLGI No. 1 grease.
  - b. Apply a few drops of S.A.E. No. 50 oil to hook thrust bearings.
- (\*) National Lubricating Grease Institute.

### LUBRICATE LIMIT STOP LEVER

- a. Apply a few drops of S.A.E. No. 50 oil to pivot points of limit rod.
- b. Apply a few drops of S.A.E. No. 50 oil to shaft bearing at rear of electrical compartment.

### LUBRICATE LIMIT SWITCH

Provide a light film of NLGI No. 2 grease on bevel gear of limit switch.

# INSPECTION AND PREVENTIVE MAINTENANCE

## GENERAL

YALE, Series Y80, hoists are inspected and tested at the factory. Regular in service inspection and preventive maintenance programs not only help reduce overall maintenance costs but may also prevent serious shutdowns by forewarning of problems that could cause these shutdowns. Regular inspections, periodic minor adjustments, regular cleaning and lubrication and replacement of worn parts can help preserve good performance and operation of your hoist.

Many factors influence the inspection and preventive maintenance program required for your hoist. Frequency and severity of service and material handled, local environmental conditions and various applicable codes are some of the factors that the user must consider to adjust inspection and maintenance program outlined in this section to meet his specific conditions.

The inspection and maintenance services outlined in this section are considered minimum. Recommended in the schedule are minimum inspection and maintenance intervals based on average daily use in a normal environment. Average daily use is based on 1000 operational hours per year maximum and intermittent operation of the hoist eight hours per day, five days per week with a maximum 40% "on" time and the average loading not exceeding 65% of rated load.

Environmental conditions in which the hoist operates are also important considerations for the user when adjusting hoist inspection and maintenance programs to local conditions. Frequency of inspection and maintenance must be increased if hoist is subjected to severe atmospheric environmental conditions, such as corrosive vapors, extreme heat or cold, cement or dust and other airborne contaminants. The user should carefully consider all environmental conditions and adjust frequency and degree of maintenance for his local conditions. Consult Application Engineering for advice for unusual environmental conditions.

Various codes also regulate inspection and maintenance programs. Attention must be given to applicable Federal Standards, OSHA regulations, National Standards, state and local codes which may include mandatory rules relating to hoist inspection and maintenance. The user should become familiar with all applicable codes for his area and be guided accordingly.

Listed on the Recommended Inspection and Maintenance Schedule are inspection frequencies and requirements. Perform these inspections regularly as scheduled and additional inspections as may be required for activity, service and environment of your hoist. The hoist operator must be responsible for determining the operating conditions and severity of service.

### Inspection Schedule and Maintenance Report Form.

Shown on page 10 of this manual is a recommended Inspection Schedule and Maintenance Report form which lists various components of the hoist. The form also includes trolley components, runway components, and miscellaneous items. This form is suggested as a guide for written inspection reports. Inspections are recommended each month and should be performed thoroughly enough to inform the hoist user of deficiencies for any item listed. This form does not supersede the Inspection and Maintenance Schedule listed below but may be used to record scheduled inspection and maintenance services required.

The user should revise the inspection interval, add additional units or provide a similar form to suit particular conditions which may exist. However, written, dated and signed inspection reports should be maintained particularly on critical items, such as hoist hooks, hoisting ropes, sheaves, drums and brakes. Periodic review of old inspection reports can point out service life of hoist components, forecasting need for adjustment, repair or replacement of these components.

As a matter of expedience, appointed maintenance personnel inspecting the hoist can also take care of minor adjustments, repairs and cleaning, where required. Note the column on Inspection Schedule and Maintenance Report form headed **Corrective Action and Notes**. When corrective action is made during inspection, note condition of part or unit as inspected in appropriate **Condition** column with a check mark (✓). Note "during inspection" corrective action taken and date in space provided. In this manner, items requiring further attention will be checked (✓) without showing

corrective action. This will advise the designated person responsible for hoist operation and safety, who reviews the reports, that deficiencies exist. The designated person will check all deficiencies as listed and reexamine or otherwise determine whether they constitute a safety hazard.

## WARNING

Deficiencies may be hazardous to personnel and equipment. Do not operate a hoist having deficiencies unless a designated qualified person has determined that these deficiencies DO NOT constitute a safety hazard.

Written, dated and signed inspection reports for many items are mandatory under OSHA regulations, and many state safety codes. It is strongly recommended that the Inspection Schedule and Maintenance Report, shown herein, be completed by a qualified person designated with the responsibility for hoist operation and safety or an inspector appointed by this person.

Inspection records can point out the service life of hoist components and help forecast the need for adjustments, repairs and ordering of replacement parts. File and review these reports after each inspection.

## WARNING

Do not operate a hoist having unusual vibrations, sounds or other conditions. Danger may be present that the hoist operator cannot see. Determine and correct cause of unusual conditions and make certain the hoist can be operated safely. Be certain to disconnect power to the hoist whenever electrical cover is removed.

## INSPECT LOWER BLOCK

- a. Check lubrication of all parts. If the thrust bearing is not equipped with a grease fitting, lubricate with SAE No. 50 oil. Also lubricate the shank of the hook which passes through the lower block body.
- b. Check each sheave to ensure rope groove is smooth and free from burrs, or other surface defects.
- c. Check each sheave for freedom of rotation; replace bearings if defective.
- d. Make certain that dowel pin, holding the hook nut to the hook, is securely in position.
- e. If hook is equipped with a safety latch or rotational lock, check to determine that they are in good operating condition.
- f. Check throat opening of hook. (Refer to Figure 5-1.) It is recommended that upon receipt of the hoist a measurement be made and recorded of the hook throat opening. OSHA Standards require that the hook be replaced if the throat opening exceeds 15 percent of the original opening, or if the hook is twisted more than 10 degrees from the unbent plane. A gage block, properly identified to the hoist, similar to the one shown in Figure 5-1, is suggested to be made for each hook for use in these measurements. For hooks with certain kinds of safety latches it may be necessary to remove latch to measure hook opening.
- g. Hooks showing signs of cracks must be replaced. Hooks should be inspected at least once per year using dye penetrants, magnetic particle or other suitable crack detecting methods.

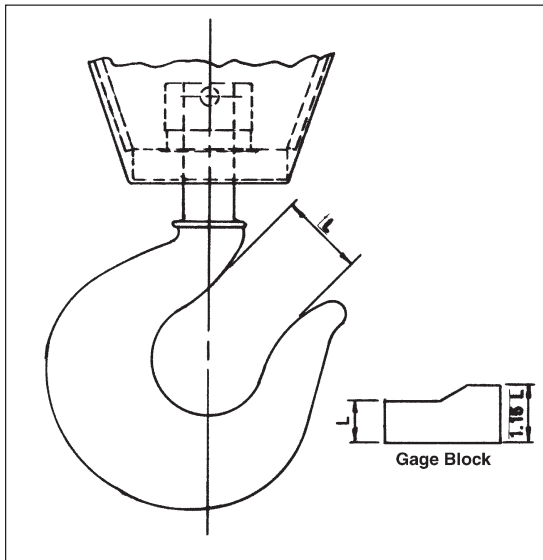

Figure 5-1. Method of measuring hook throat opening

- h. Check wear of the hook, especially at the saddle and replace if badly worn.

### INSPECT UPPER BLOCK AND HOIST SUSPENSION

- a. Check upper block sheaves (when hoist is so equipped) for wear, damage and freedom of rotation. If sheaves do not rotate freely, disassemble block and inspect bearings. Replace worn or damaged bearings, washers, pins or sheaves.

- b. Make certain that all sheaves, bearings and hanger pins are free of foreign material and properly lubricated. Bearings without grease fittings are lubricated for the life of the bearing and require no further lubrication. After inspection, lubricate all upper block lubrication fittings.
- c. Make certain that rope guide pins are not bent, loose or otherwise distorted; guide pins must have close clearance to sheave flange to keep rope in sheave grooves.
- d. Check hoist suspension bolts on lug suspended hoists; make certain that bolts are secure, properly tightened and free from damage.
- e. Inspect suspension lug at top of hoist frame for damage, cracks, hole elongation or other signs of wear. On all hoists, the suspension lug is integral with hoist frame and the entire frame must be replaced when suspension lug is damaged and requires replacement.

## ⚠ WARNING

Do not operate hoists having worn or damaged suspension bolts.

- f. If disassembly is required reinstall all parts following procedure in reverse of disassembly.

### INSPECT ELECTRICAL CONTROLS

Arrangement of electrical control equipment varies with the type of control, physical space and the optional control features ordered with the hoist.

- a. Disconnect electrical power to hoist, remove electrical compartment cover (Figure 9-1, Ref. No. 29) and inspect wiring and terminals. Terminals should be securely crimped to wires and electrical insulation should be sound. Terminal screws should be tight.
- b. Check condition of contactor assembly, transformer, and limit stop and reverse switches.

# INSPECTION SCHEDULE AND MAINTENANCE REPORT

HOIST SERIAL NO. (MFGRS) \_\_\_\_\_  
 RATED LOAD \_\_\_\_\_  
 TYPE \_\_\_\_\_  
 VOLTAGE \_\_\_\_\_

CUSTOMER CRANE IDENTITY NO. \_\_\_\_\_  
 LOCATION IN PLANT \_\_\_\_\_  
 THIS INSPECTION IS: MONTHLY  ANNUAL   
 SEMI-ANNUAL   
 INSPECTED BY \_\_\_\_\_ DATE \_\_\_\_\_

COMPONENT, UNIT OR PART and location		*Recommended Inspection Interval			CONDITION (Check column best indicating condition when part or unit is inspected. Use note column to the right if condition is not listed below.)							CORRECTIVE ACTION NOTES
		MONTHLY	SEMI-ANNUAL	ANNUAL	GOOD	ADJUSTMENT REQUIRED	REPAIR REQUIRED (Loose Parts or Wires)	REPLACEMENT REQUIRED (Worn or Damaged)	LUBRICATION REQ. (Low Oil or Grease Rust or Corrosion)	CLEANING OR PAINTING REQUIRED	DATE	
HOIST	Motor	<input type="radio"/>										
	Motor Brake	<input type="radio"/>										
	Mechanical Load Brake	<input type="radio"/>										
	Overload Clutch	<input type="radio"/>										
	Couplings	<input type="radio"/>										
	Gears, Shafts & Bearings	<input type="radio"/>										
	Upper Block	<input type="radio"/>										
	Lower Block	<input type="radio"/>										
	Hook & Throat Opening	<input checked="" type="radio"/>		<input checked="" type="radio"/>								Record Hook Throat Opening
	Hoist Rope	<input checked="" type="radio"/>										
	Rope Drum		<input type="radio"/>									
	Guards		<input type="radio"/>									
Limit Switch	<input type="radio"/>											
CONTROL STATION OR PUSHBUTTON	Pushbutton		<input type="radio"/>									
	Wiring		<input type="radio"/>									
TROLLEY	Motor	<input type="radio"/>										
	Brake (when so equipped)	<input type="radio"/>										
	Couplings	<input type="radio"/>										
	Gears, Shafts & Bearings	<input type="radio"/>										
	Frame			<input type="radio"/>								
	Wheels		<input type="radio"/>									
	Bumpers		<input type="radio"/>									
	Guards		<input type="radio"/>									
	Conductors	<input type="radio"/>										
	Collectors	<input type="radio"/>										
RESISTORS	Hoist		<input type="radio"/>									
	Trolley		<input type="radio"/>									
RUNWAYS	Monorail Joints		<input type="radio"/>									
	Monorail		<input type="radio"/>									
	Main Conductors	<input type="radio"/>										
	Main Collectors	<input type="radio"/>										
MISC.	General Condition		<input type="radio"/>									
	Load Attach. Chains	<input checked="" type="radio"/>										
	Rope Slings & Connect.	<input checked="" type="radio"/>										
	Change Gearcase Lub.			<input type="radio"/>								
Grounding Faults		<input type="radio"/>										

\* See text for DAILY & WEEKLY REQUIREMENTS  
 INSPECTION INTERVAL

● SIGNED & DATED REPORT REQUIRED - OSHA  
 X MAGNETIC PARTICLE OR EQUIVALENT EXAMINATION REQUIRED.

Typical Inspection Schedule and Maintenance Report form. For recommended inspection intervals, see figure 5-2.  
 User must adjust inspection interval and components to suit his individual conditions and usage.

12375B

# RECOMMENDED INSPECTION AND MAINTENANCE SCHEDULE

TIME INTERVAL	INSPECTION OR MAINTENANCE
Daily or start of each shift (visual)	* Check operation of all functional mechanisms including limit switch operation, brakes and control. Check hoist cable for kinks, abrasions, corrosion or broken wires or evidence of improper spooling on drum. Inspect hooks, upper and lower blocks, and all load bearing components for damage.
1 Month	* HOIST CABLE - Inspect and lubricate per Paragraph 5-8.
1-3 Months	* ELECTRICAL CONTROLS - Inspect per Paragraph 5-4. Check hoist gearcase oil level - add oil as required per Paragraph 4-2.
6 Months	* LOWER BLOCK - Inspect per Paragraph 5-2. UPPER BLOCK - Inspect per Paragraph 5-3.
Annually	* Motor brake and actuating mechanisms. Inspect and adjust per Paragraph 5-5. Inspect hooks with crack detecting procedures per Paragraph 5-2. Drain and refill hoist gearcase per Paragraph 4-2. See note 1.
6 Months or 500-750 hours "on" time	* Inspect electrical controls per Paragraph 5-4. Change hoist gearcase oil - Fill with oil per Paragraph 4-2.d. Lubricate hoist cable per Paragraph 4-3. Lubricate upper and lower hook block per Paragraph 4-4. Lubricate limit stop lever per Paragraph 4-5. If a screw type limit switch is furnished, add a light film of NLGI No. 2 grease to bevel gear.
5 Years elapsed time or 5000 hours "on" time	* Complete inspection, disassembly, and maintenance required. It is recommended that your YALE Repair Station be contacted for this service.

\*Perform services described by paragraph indicated.

Figure 5-2. Inspection and Maintenance Schedule

## INSPECT MOTOR BRAKE (SEE NOTE 1)

See Figure 9-3.

- Check braking surfaces for wear and scoring. Replace badly worn or scored parts. Check spring studs and guide pins to make sure they are not bent or loose. Check coil shock mounts for deterioration and damage. Check air gap adjustment. (See 7-2).

## INSPECT MECHANICAL LOAD BRAKE GEARING AND OVERLOAD CLUTCH (OPTIONAL) (SEE NOTE 1)

- The mechanical load brake and gearing may be inspected and serviced with hoist suspended. To do so, remove lower block and wire rope, drain oil from gearcase, remove 12 hex head bolts and lockwashers holding gearcase cover, and pull cover from gearcase (Figure 5-3).

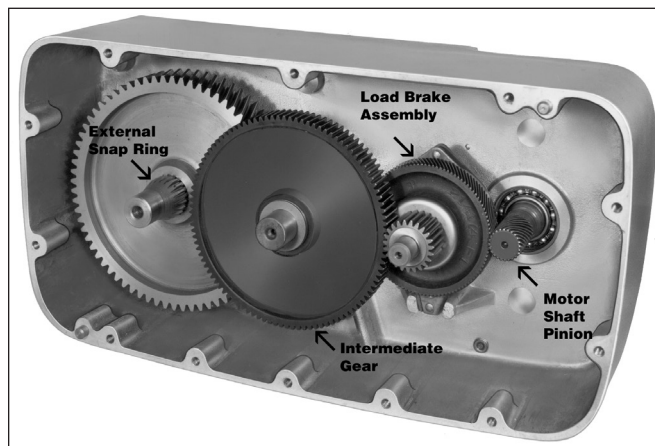

Figure 5-3. View of Gearcase – Cover Removed

- To inspect gearing, pull out intermediate gear and pinion assembly and roller thrust bearings (Figure 5-4), and load brake assembly (Figure 5-5). Do not remove drum gear unless visual inspection indicates replacement is necessary.
- Inspect gears and pinions for signs of tooth wear and damage. If replacement of any parts appears necessary, disassemble drum gear, intermediate gear and pinion assembly, and load brake assembly as directed on following page.

**NOTE 1: Load brake, motor brake, gearing, overload clutch, rope drum, and shaft inspection procedures: The detailed inspection procedures in this manual are not intended to require periodic disassembly and inspection of these components but to provide this procedure when inspection and functional testing indicates that the mechanism is not functioning properly. Per ASME B30.16 Section 16-2.1.4 (c) Periodic inspection – “A qualified person shall determine whether conditions found during inspection constitute a hazard and whether disassembly is required”. In keeping with this requirement, when the qualified person determines disassembly is required the inspection procedures in this manual should be used.**

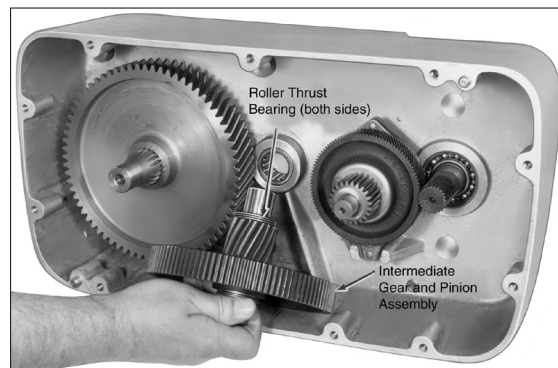

Figure 5-4. Removing Intermediate Gear and Pinion Assembly

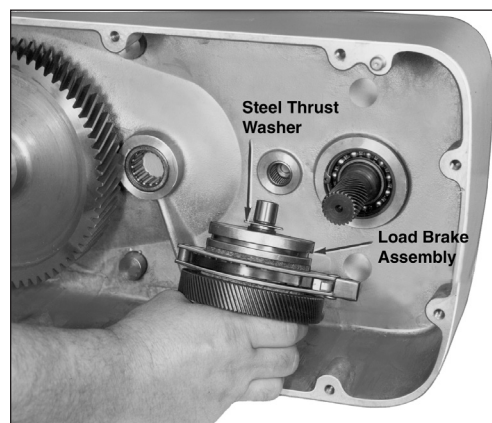

Figure 5-5. Removed Load Brake Assembly

- d. To disassemble drum gear, remove external snap ring from splined shaft, using heavy-duty snap ring pliers, and pull off gear.
- e. To disassemble intermediate gear and pinion, press pinion shaft from gear using an arbor press.
- f. It is recommended that load brake assembly be returned to an Authorized YALE Repair Station for inspection and repair. If it is necessary that you make your own inspection and repair, instructions below must be followed:
  1. Place load brake assembly, flange up, in a vise equipped with brass or copper jaw plates to protect pinion gear teeth. Remove snap ring from end of load brake shaft (Figure 5-6).



Figure 5-6. Remove Snap Ring From Load Brake Shaft

2. Using a puller tool, remove brake flange from shaft. A groove is provided around outer diameter for this purpose. See Figure 5-7. Remove key from shaft and lift off 2 friction discs, and the pawl and ratchet assembly (Figure 5-8).



Figure 5-7. View Showing Load Brake Flange Removed

3. Remove load brake gear. If replacement of spring, spring retainer or cam is necessary, press off shaft (Figure 5-9).
4. The load brake pawl and ratchet is a riveted assembly and is not to be disassembled.
5. Clean all parts thoroughly and inspect for wear and damage. Replace all parts that are excessively worn or damaged. Hard surface or glazed friction discs should be replaced.

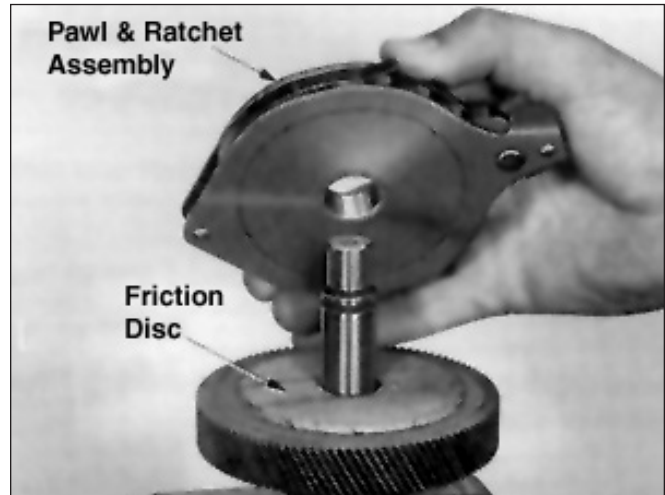
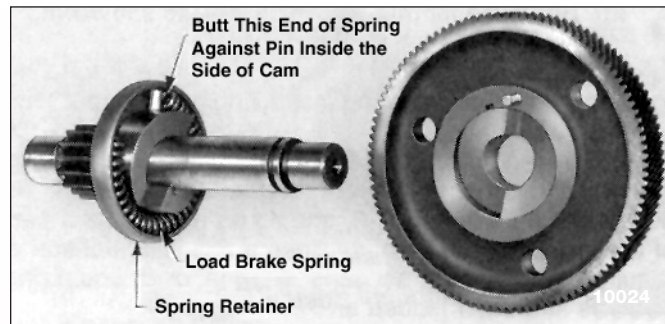

Figure 5-8. Removing Pawl and Ratchet Assembly From Load Brake Shaft

- g. Reassemble gearing and load brake parts following reverse procedure of disassembly. In assembling load brake, observe assembly steps (1) through (4).

1. Before installing spring in its retainer (Figure 5-9), apply a good grade of ball bearing grease to inside of retainer. Spring must be positioned exactly as illustrated, butted against pin at side of cam.



Load Brake - Standard

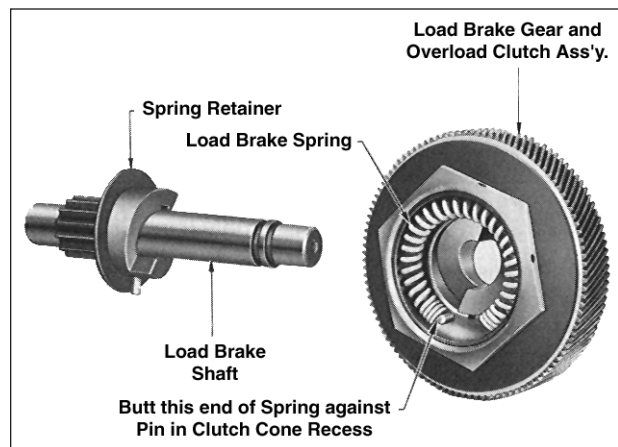

Load Brake - Overload Clutch

Figure 5-9. Load Brake Gear Removed From Load Brake Showing Load Brake Spring

2. When installing pawl and ratchet assembly on load brake shaft, be certain that teeth on ratchet face are in the same direction as shown in Figure 5-8. The ratchet assembly should rotate freely when turned counterclockwise and the pawl should engage ratchet teeth when unit is turned clockwise.
3. When installing brake flange, position it with chamfer facing friction disc (Figure 5-7).

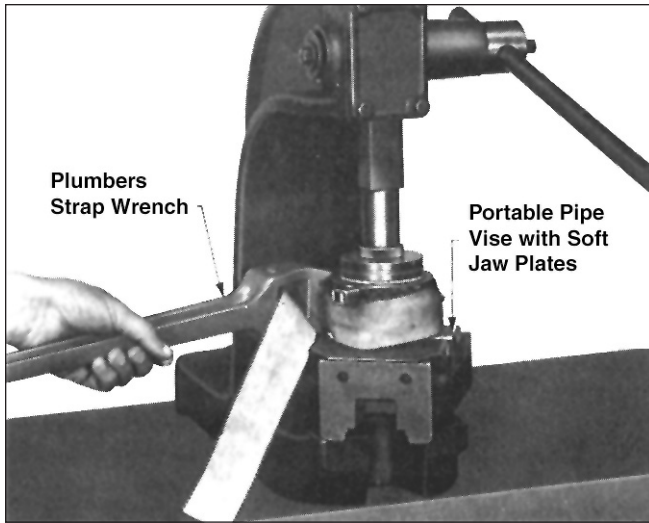

Figure 5-10. Winding Load Brake Gear using a Strap Wrench to set up Load Brake Spring

4. The brake spring must be pre-loaded at assembly to a torque of 10 to 14 lb.-ft. This is accomplished using a plumber's strap wrench to wind (rotate) load brake gear to set up spring (Figure 5-10) while pressing brake flange into place using an arbor press. Clamp pinion end of shaft into a portable vise to keep brake from rotating in press. Use brass or copper jaw plates on vise to protect pinion gear teeth. Wind gear counterclockwise (viewing brake from flange end) with strap wrench and press down on flange until snap ring groove in shaft is exposed allowing snap ring to be installed. Use extreme care not to over wind spring as yield will result and final spring torque will be reduced. Do not wind gear beyond point necessary to install snap ring in groove.
- h. Install gearing and load brake assembly in gearcase in reverse order of disassembly. Be certain roller thrust bearings are installed at both ends of intermediate gear shaft as shown in Figure 5-4 and that thrust washers are properly installed at both ends of load brake shaft as noted below:
  1. A steel thrust washer with 5/8" I.D. must be installed on the brake flange end (end opposite pinion) of load brake as shown in Figure 5-5.
  2. A bronze thrust washer with a lug on one side goes on pinion end of load brake shaft and it must be installed so that its lug engages the special slot located on the spot face surrounding the load brake bearing bore inside gearcase cover. Use heavy grease to hold it in place on cover as cover is installed.

On hoists with 18 or 20 tooth load brake pinion, an 11/16" I.D. steel thrust washer is installed between pinion and bronze thrust washer.

- i. At completion of reassembly of gearing and load brake in gearcase, refill gearcase to proper level using correct grade of oil, as outlined in Section IV - LUBRICATION.
- j. For hoists equipped with an overload clutch (optional) which has been functioning properly, visually inspect clutch adjusting nut and spring washer for signs of damage or looseness. With a small hex allen wrench, make certain two set screws in adjusting nut are tight. **DO NOT TURN ADJUSTING NUT OR DISASSEMBLE CLUTCH.** If spring washer, adjusting nut or gear is loose or damaged, or the clutch did not function properly before disassembly of hoist for inspection, consult the nearest YALE Authorized Repair Station for repair or adjustment.

### INSPECT ROPE DRUM AND SHAFT (SEE NOTE 1)

- a. To remove drum, remove wire rope, electrical compartment cover and electrical panel assembly (Figure 9-1) and gearing and load brake assembly (paragraph 5-6).
- b. Remove four hex socket head bolts securing gearcase to cover. Three bolts are accessible from inside frame (Figure 2-2, Section II) and the fourth is accessible from electrical

end of frame through special access hole using a socket hex key wrench with an extension (Figure 5-11). With bolts removed, pry assembled gearcase and motor from frame. Exercise caution so that gearcase and motor assembly does not fall as it comes free of frame. This disassembly operation is not recommended with hoist suspended. Drum will remain in frame and can be lifted from drum shaft. To remove shaft, remove internal retaining ring from bearing bore in frame.

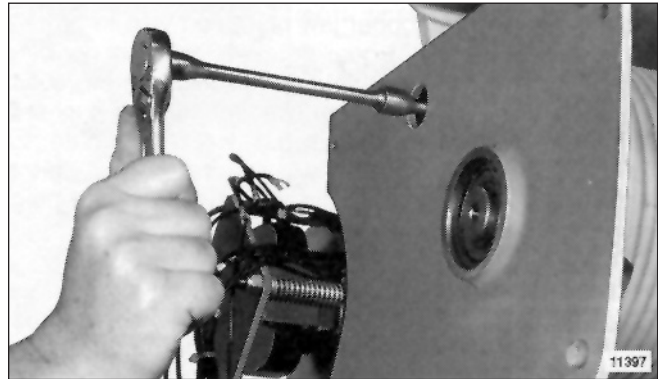

- c. Check parts for wear and damage. Replace drum if there are any signs of cracks or other damage.

### ROPE INSPECTION, MAINTENANCE AND REPLACEMENT

#### **⚠ WARNING**

Wire rope improperly handled or abused can create a SAFETY HAZARD. Read and comply with inspection, maintenance and replacement information given herein.

- a. **Inspection.** Wire rope on your hoist is one of the most important components requiring frequent inspection and maintenance. All wire ropes will eventually deteriorate to a point where they are not safe and will require replacement. **WIRE ROPE SHOULD BE THOROUGHLY INSPECTED AT REGULAR MONTHLY INTERVALS BY AN AUTHORIZED PERSON AND A DETERMINATION MADE WHEN FURTHER USE OF THE ROPE WOULD CONSTITUTE A SAFETY HAZARD.** Each inspection should include a written, dated and signed report of rope condition. Reports should be filed and reviewed each month and any rope deterioration carefully noted.

Inspections revealing rope deterioration, including, but not limited to the following conditions should cause the inspector to question remaining strength of rope and consider replacement:

1. Twelve randomly distributed broken wires in one rope lay or four broken wires in one strand.
2. Wear of one-third of the original diameter of outside individual wires.
3. Kinking, crushing or bird caging.
4. Heat damage from any cause.
5. Reductions from nominal diameter of more than 1/64" for 3/16", 1/4", and 5/16" diameter rope.
6. Rope corrosion, internal or external.
7. Effects from improper lubrication.
8. Rope idle for month or more due to shutdown.

Special attention should be exercised when inspecting rope normally hidden during inspecting procedures.

- b. **Maintenance.** Keep rope well lubricated to help reduce internal friction and prevent corrosion. Lubricant, as described in paragraph 4-3, should be applied as a part of the regular maintenance program. Special attention is required to lubricate sections of rope over equalizing sheaves and other hidden areas.

Avoid dragging ropes in dirt or around sharp objects which will scrape, nick, crush or induce sharp bends in the rope.

- c. **Replacement.** When recommended by an authorized inspector, the rope should be replaced. Replacement rope assemblies are shipped from the factory carefully coiled to prevent damage by kinking. Care must be taken to avoid twisting or kinking when uncoiling and handling during reeving.

Before replacing rope, check condition of grooves in sheaves and drums to determine if they are excessively worn.

## **WARNING**

Use only factory approved rope with swagged wire rope sockets.

When first using the hoist after rope replacement, break-in rope by operating under lighter loads to full travel before applying maximum load.

### **ROPE REEVING**

- a. **General.** Before unreeling rope from a coil or reel, be sure floor is clean. Dirt picked up by the rope can cause excessive wear and abrasion. Uncoil the rope by rolling the coil or reel along the floor; or, place reel on a stand with a shaft through the center of reel so rope can be pulled straight out with the reel rotating.

## **CAUTION**

It is imperative that the rope reel or coil rotates as rope unwinds. If coil or reel does not rotate, the wire will be twisted as it is uncoiled and kinking will result. A kinked rope may be damaged and unsafe for maximum service.

Before removing the old rope, refer to reeving diagrams, (Figures 5-12, 5-14, 5-15 and 5-17). Face the rope drum on your hoist from the side which the rope comes off drum. To assist with reeving your hoist, select the reeving diagram for your hoist. Note the description (such as 2 part double reeved, Figure 5-17) and refer to the paragraph below with the same description which describes reeving procedure.

- b. **Removing old rope** - for all reevings.

1. Lower the bottom block to a scaffold located 6 to 7 feet below hoist to relieve tension on wire rope. (Bottom block may be lowered to floor if desired; however, to handle less weight and for ease of reeving adequate scaffold below the hoist is recommended.)
2. Remove bottom block sheave guard.
3. Remove key plates from both sides of sheave pin and slide sheave pin from bottom block.
4. Lift out sheaves from the top of the bottom block and remove wire rope.
5. Remove key plates or snap rings from upper block sheave(s) and slide out upper block sheave pins, releasing upper block sheaves. Remove wire rope from sheaves.
6. Make certain all personnel are clear of hoist and operate hoist ↓ to completely unwind all wire rope from drum. Stop hoist so drum anchor slot(s) is accessible. Remove live rope and socket(s) from drum.
7. **TURN OFF POWER TO HOIST**
8. Remove the bolt and lockwasher in the end of the rope anchor fitting. Remove rope from slot in top of anchor.

- c. **Installing new rope.**

## **WARNING**

Winding rope on rope drums with power can be hazardous. Keep hands safe distance from drum, wear gloves and use extreme care when winding rope.

### **SINGLE REEVED HOISTS**

Stretch new cable on floor in one continuous length. Make certain there is no twist in rope.

1. Place one end of rope in rope drum anchor slot. Be sure end fitting is properly seated.
2. With all personnel clear of hoist - **TURN ON POWER.**
3. Operate hoist ↑ guiding new rope into drum grooves with gloved hand, until the following lengths remain unwound:
  - (a) 2 part single reeved - about 14'-0"
  - (b) 4 part single reeved - about 28'-0"
  - (c) 6 part single reeved - about 42'-0"
4. Proceed with reeving as described in appropriate paragraph below and the reeving diagram for your hoist.

### **DOUBLE REEVED HOISTS**

Stretch new cable on floor in one continuous length. Make certain there are no twists in rope.

1. Pull far end of rope toward end of rope nearest hoist, until both ends are even and a loop is formed. Place fittings on both ends of rope in anchor slots on rope drum. Be sure end fittings are properly seated.
2. With all personnel clear of hoist - **TURN ON POWER.**
3. Operate hoist ↑ guiding rope into grooves at both ends of drum, until the distance from the drum to the loop is about 28' for 2 part double reeved.
4. Proceed with reeving as described in appropriate paragraph below and the reeving diagram for your hoist.

- d. **Reeving - 2 part single.**

See Figure 5-12, for diagram.

See Figure 9-11 for block parts.

With new rope installed on drum as described in Paragraph 5-9c, single reeved above, proceed with reeving following steps below:

1. Pass other end of rope through bottom opening of hoist, between floating limit rod and motor, and attach rope to cast dead end anchor fitting. A slot is located at top of fitting to accept cable. Reinstall bolt and lockwasher in end of anchor fitting to lock rope compression fitting in place.
2. Grasp loop, formed after installing end anchor, and place bottom block sheave in loop. Lower sheave into bottom block and insert sheave pin. Replace key plates and bolts holding sheave pin in place.
3. Replace sheave guard. Make certain rope is not twisted. Should the two parts of rope tend to wind around each other, remove cable from anchor slot and untwist cable. Reattach the cable anchor.
4. Lubricate cable per Paragraph 4-3.

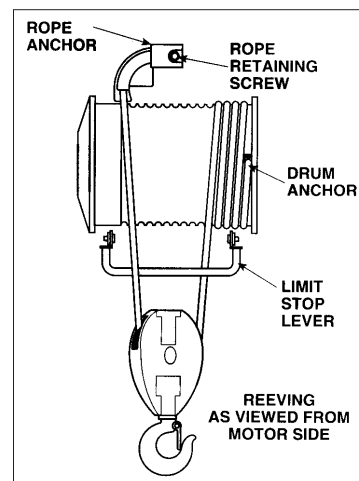

Figure 5-12. Hoist Reeving - Two Part Single



**e. Reeving - 4 part single.**

See Figure 5-14 for diagram.

See Figure 9-13 for block parts.

With new rope installed on the drum as described in paragraph 5-9c single reeved above, proceed with reeving following steps below:

1. Grasp the cable near the middle (about 14'-0") of the unwound end and form a loop. Place upper sheave in this loop. Slide upper sheave with cable into sheave pocket.
2. Insert sheave pin into sheave. Replace key plates and bolts to hold sheave pin in place.

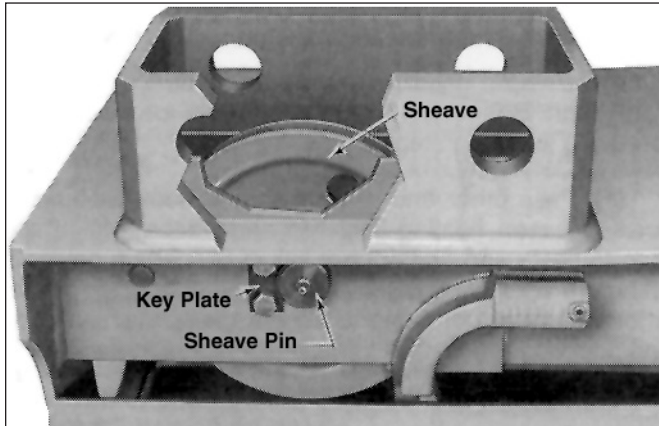

Figure 5-13. Upper Sheave Installed (Typical 3 and 5 Ton)

3. Pass free end of rope through bottom opening of hoist between floating limit rod and motor, and insert rope in anchor fitting at hoist frame. Be certain power is off before attempting to place rope in anchor fitting. With end fitting properly seated in anchor, replace bolt and lockwasher in end of socket. Two loops have now been formed for bottom block sheaves.

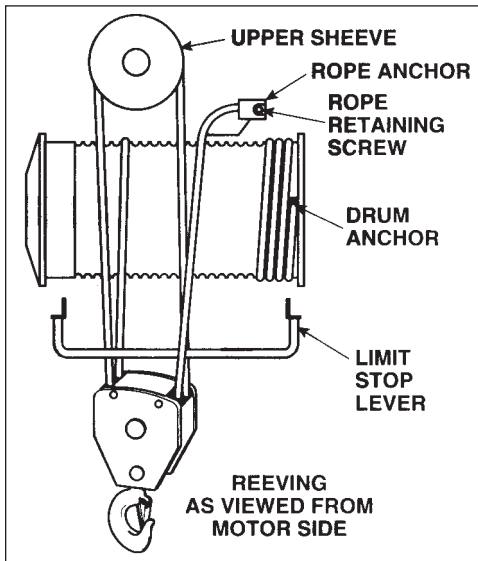

Figure 5-14. Hoist Reeving - Four Part Single

4. Place one sheave in each loop. Install one sheave with cable in bottom block, partially insert sheave pin to hold sheave in place. **Note:** Some blocks have spacer washers between sheaves. Be certain that washers are installed between sheaves, when shown on parts illustration. Install second sheave with cable into bottom block. Slide sheave pin through sheave. Replace key plates and bolts securing sheave pin.
5. Replace sheave guard.
6. Lubricate cable per paragraph 4-3.

**f. Reeving - 6 part single.**

See Figure 5-15 for diagram.

See Figure 9-13 for block parts.

With new rope installed on the drum as described in paragraph 5-9c single reeved above, proceed with reeving following steps below:

1. Grasp cable at a point one-third (approx. 14'0") the distance hanging below the rope drum and form a loop. Place one upper sheave in this loop. Slide upper sheave with cable into sheave pocket; partially insert sheave pin to hold sheave in place.
2. Repeat (1) above and install second upper sheave with rope. Insert sheave pin and install key plates and bolts to secure sheave pin.

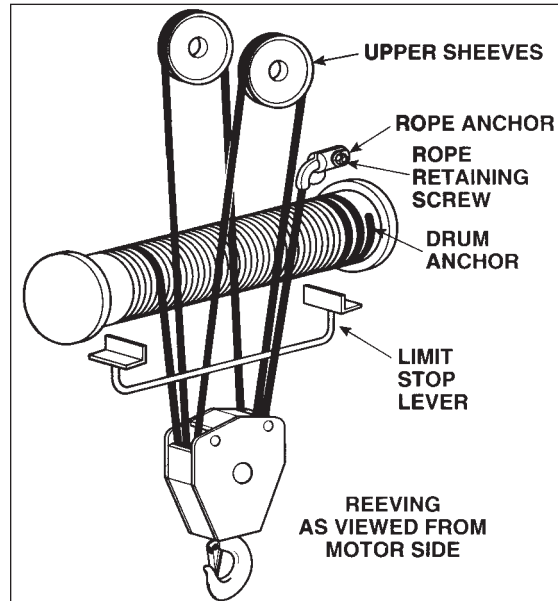

Figure 5-15. Hoist Reeving - Six Part Single

3. Pass free end of rope through bottom opening of hoist between floating limit rod and motor and insert in rope anchor fitting at hoist frame. Be certain power is off before attempting to place rope in anchor fitting. With end fitting properly seated in anchor, replace bolt and lockwasher in end of socket. Three loops have now been formed for bottom block sheaves.
4. Place sheave in each loop. Install one sheave with cable in bottom block; partially insert sheave pin to hold sheave in place. **Note:** Be certain that washers are installed between sheaves, as shown on parts illustration.
5. Repeat step 4 for remaining bottom block sheaves. Install sheave pin through sheaves. Replace key plates and bolts securing sheave pin.
6. Replace sheave guard.
7. Lubricate cable per paragraph 4-3.

**g. Reeving - 2 part double.**

See Figure 5-17 for diagram.

See Figure 9-10 for block parts.

With new rope installed on the drum as described in paragraph 5-9c double reeved above, proceed with reeving following steps:

1. Form loops in the two ropes coming from rope drum. Place these loops into bottom block pockets and slide pipe or rod through sheave pin holes. Note position of ropes passing limit stop bar.
2. Partially insert upper block sheave pin in opening and install one spacer washer. Raise remaining rope up to hoist, form a loop and place upper sheave in this loop.

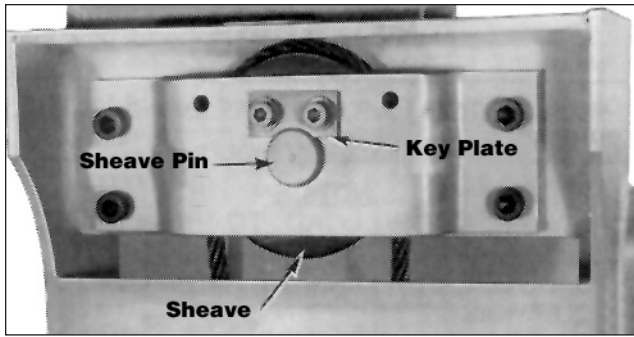

Figure 5-16. Upper Sheave Installed (Typical)

3. Place sheave with rope into upper sheave pocket and slide pin partially through sheave. Install remaining washer and push pin through side plates. Install snap ring on each end of pin to secure pin in place.

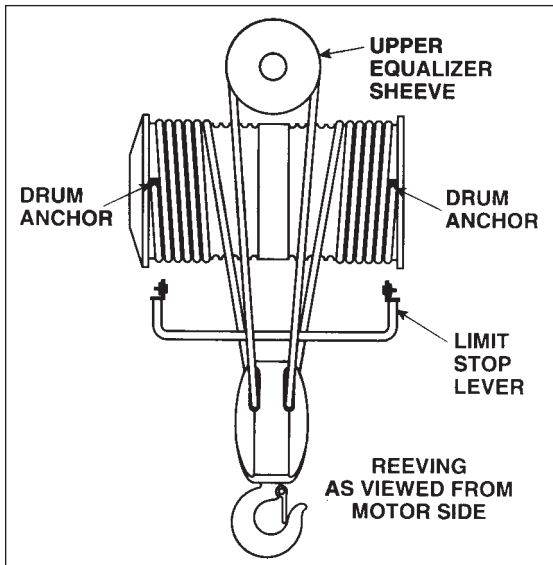

Figure 5-17. Hoist Reeving - Two Part Double

4. To remove rope twist in single reeved hoists.
  - (a) Observe direction block tends to rotate.
  - (b) Lower the block to a low position and turn off power.
  - (c) Rotate rope near the anchor end several turns in a direction tending to correct block rotation. This rotates rope end fitting in the anchor.
  - (d) Turn on power; raise and lower the block several times to feed the correcting twist in the rope through the reeving.
  - (e) If block still tends to twist, repeat the above procedure until block rotation is corrected.
5. To remove rope twist in double reeved hoists.
  - (a) Observe direction block tends to rotate.
  - (b) Lower the bottom block unspooling rope from rope drum until only one quarter (1/4) turn remains to rope end anchors in drum.
  - (c) Rotate rope near ends entering drum in a direction tending to correct block rotation. This rotates rope end fittings in the drum.
  - (d) Turn on power; raise and lower the block several times to feed the correcting twist in the rope through the reeving.
  - (e) If block still tends to twist, repeat the above procedure until block rotation is corrected.

#### h. Checking for and removal of rope twisting.

Although rereeving of hoist may have been done carefully, sometimes after new rope has been installed twisting may occur. With new rope installed, the hoist block should be raised and lowered several times with gradually increasing loads, through full lift. If the block still rotates excessively at no load, the rope may have twists which should be removed.

### TESTING HOIST AND OVERLOAD CLUTCH (OPTIONAL) (SEE NOTE 1)

- a. **General.** Before placing hoist in service or after disassembly and reassembly, hoist should be tested. To test suspend hoist from an overhead supporting member of sufficient strength to support the weight of the hoist and the rated load. Hoists having overload clutches, require an overhead supporting structure capable of supporting with appropriate safety factor, a load equal to 200 percent rated load and the weight of the hoist. Connect hoist to power supply as shown on hoist nameplate and perform the checks listed in b and c below.

- b. **Check hoist as outlined** in PRE-OPERATION CHECKS, Section II, paragraph 2-4.

- c. **Check hoist with capacity load.**

1. Attach rated load to lower hook.
2. Depress push button and raise load. When push button is released, hoist should immediately stop and hold load at that level.
3. Depress push button, lower load a short distance and release button. Hoist should stop immediately and hold load at that level.

**Note: If load drifts downward slowly in step 2 or 3 above, motor brake requires adjustment - see MOTOR BRAKE ADJUSTMENT - Section VII - paragraph 7-2.**

4. Insert lower sheave pin into bottom block removing pipe as sheave pin is inserted. Be certain washers are replaced as shown on parts illustration. With sheave pin installed, replace key plates and bolts to secure sheave pin.
5. Replace sheave guard.
6. Lubricate rope per paragraph 4-3.

- d. **Overload Clutch.** The overload clutch (optional) must be tested for proper operation before placing hoist in service or after disassembly and reassembly of hoist. For test procedure follow instructions listed below.

## ⚠ WARNING

BEFORE ATTEMPTING TO TEST THE OVERLOAD CLUTCH, MAKE CERTAIN THE FOLLOWING PREREQUISITES ARE STRICTLY OBSERVED:

- a. **An appointed person must determine, before starting, that all structures supporting the hoist are adequately strong to withstand the test load of 200% of the rated load, plus the weight of the hoist, whether hoist is tested in installed position or moved to a designated test facility.**
- b. **Loads used for testing must be accurately known.**
- c. **Test must be made ONLY by a qualified operator, thoroughly familiar with the hoist and the purpose of the test.**
- d. **Adequate and proper rigging must be provided to ensure that test loads are securely attached, properly balanced, and lifted level. Failure to provide adequate support could cause injury to personnel and/or damage to equipment.**

1. Using a known load, equal to the hoist rated load, energize hoist to lift the load. Raise this load just high enough to be certain hoist is lifting the entire load. **Clutch should not slip with the rated load.** Lower load to rest position. If clutch slips with rated load, **adjustment is required.** (See paragraph 7-5. - "OVERLOAD CLUTCH ADJUSTMENT".) If hoist will lift rated load, proceed to step (2).

2. Increase load in steps from rated load, TO A MAXIMUM OF 200% of the rated load, attempting to lift load with each increase in weight. Hoist Overload Clutch should slip and refuse to lift load **before** 200% of the rated load is reached. Should hoist lift 200% of the rated load - **STOP TEST** - A CLUTCH ADJUSTMENT IS REQUIRED. (See paragraph 7-5 - "OVERLOAD CLUTCH ADJUSTMENT".)
3. Run hoist with load causing clutch to slip (hoist refusing load) five cycles of approximately 1 second each.

## CAUTION

To prevent overheating, release the hoist control button at once when the hoist refuses to lift the load.

4. Remove weights added in step (2) and return to hoist rated load. Lift rated load one final time. Clutch should not slip.

## WARNING

Do not lift more than rated load except for test purposes.

**NOTICE: ALWAYS KNOW LOAD TO BE LIFTED, LIFT-TECH DOES NOT RECOMMEND LIFTING LOADS GREATER THAN THE RATED LOAD OF YOUR HOIST.**

# TROUBLESHOOTING

Problem	Probable Cause	Remedy
1. Hoist Will Not Operate.	A. No Power to hoist	A. Check switches, circuit breakers or fuses and connections in power supply lines.
	B. Wrong voltage or frequency	B. Check current rating on motor data plate against power supply
	C. Loose or broken wire connections in hoist electrical system	C. Shut off power supply, open hinged cover on hoist and check wiring connections. Also check connections in push button station and limit switches.
	D. Contactor assembly not functioning	D. Check contact points. Replace if excessively burned or pitted. Check for burned out contactor coils. See that necessary jumper wires are properly installed.
	E. No control voltage	E. Check transformer fuse. If blown, check for grounding and/or shorts in the push button station. Check the transformer coil for signs of overheating. Replace transformer if burned out. Verify the transformer secondary is the same voltage as the coils to which it is connected.
	F. Motor burned out.	F. Replace motor. Check input power supply. Check hoist motor connections.
2. Hook moves in wrong direction.	A. Reverse phasing on three-phase hoists	A. Interchange any two power supply line leads. Refer to SECTION II.
	B. Hoist or push button wired wrong.	B. Check wiring connections with appropriate wiring diagram.
3. Hook will raise but not lower.	A. Lower electrical circuit open.	A. Check for loose connections. See that necessary jumper wires are properly installed on contactor.
	B. Contactor not functioning.	B. Check for burned or pitted contact points or burned out contactor coil.
4. Hook will lower but not raise.	A. Excessive load	A. Reduce loading to rated load of hoist, as shown on nameplate.
	B. Hoist circuit open	B. Check for loose connections. See that necessary jumper wires are properly installed on contactor.
	B. Contactor not functioning	B. Check for burned or pitted contact points or burned out contactor coil.
5. Hoist will not lift rated load.	A. Low voltage.	A. See that power supply current is same voltage listed on motor data plate. Check size of power supply lines.
	B. Overload Clutch not properly adjusted	B. See SECTION VII, Paragraph 7-5.
6. Load drifts excessively when hoist is stopped.	A. Excessive load.	A. Reduce loading to rated load, as shown on nameplate
	B. Motor brake not holding.	B. With No Load, check hoist for drift. If drifting is excessive, inspect motor brake (SECTION V, paragraph 5-5) and adjust as outlined in SECTION VII, Paragraph 7-2.
	C. Load brake not holding.	C. (1) After determining that the motor brake is working properly, attach rated load to hook and operate hoist. If the load accelerates during lowering, the load brake is not functioning properly. See Section V, paragraph 5-6 for replacing worn or damaged parts. (2) If load brake checks O.K., magnetic motor brake needs adjustment (see b above).
7. Hoist motor overheats.	A. Excessive load.	A. Reduce loading to rated load of hoist, shown on nameplate.
	B. Excessive duty-cycle	B. Reduce frequency of lifts or amount of jogging
	C. Wrong voltage or frequency	C. Check current rating on motor data plate against power supply. Check hoist motor connections.
	D. Defective motor or worn bearings in hoist frame	D. Disassemble hoist and inspect for defective, worn or damaged parts
	E. Overload clutch slipping without lifting load.	E. See SECTION VII, Paragraph 7-5
8. Hoist operates intermittently.	A. Collectors make poor contact.	A. Check collectors for free movement of spring arm, weak spring or electrical connections.
	B. Loose connections	B. Check all wiring for loose connections.

# BRAKE TROUBLESHOOTING

Coil Failure	
Supply Voltage Cause	Supply Voltage Correction
Line voltage >110% of coil rating	Reduce voltage or replace with proper rated coil
Excessive voltage drop during inrush time	Increase current rating of power supply
Wiring Cause	Wiring Correction
Leadwires interfering with plunger pull-in	Reroute wiring away from plunger and other moving components
Coil leadwire shorted to ground	Replace coil or leadwire and protect with wire sleeving
Solenoid Assembly Cause	Solenoid Assembly Correction
Plunger not seating flush against solenoid frame	Loosen solenoid mounting nuts and reposition frame to allow full face contact
Excessive solenoid/plunger wear at mating surface	Replace solenoid assembly
Broken shading coils	Replace solenoid assembly
Worn Parts Cause	Worn Parts Correction
Excessive wear of solenoid link bolt	Replace link bolt; also inspect plunger thru-hole for elongation
Plunger guide worn down and interfering with plunger movement	Replace guide
Application Cause	Application Correction
Machinery cycle rate is exceeding brake rating	Reduce brake cycle rate or use alternate control method
High ambient temperature (>110%) and thermal load exceeding coil insulation rating	Use Class H rated coil and/or find alternate method of cooling brake
Brake coil wired with windings of an inverter motor or other voltage/current limiting device	Wire coil to dedicated power source with instantaneous coil rated voltage
Miscellaneous Cause	Miscellaneous Correction
Wrong or over tightened torque springs	Replace with proper spring or refer to installation section for proper spring height
Excessive air gap	Reset, refer to Airgap Adjustment

Excessive Wear/Overheating	
Air Gap Cause	Air Gap Correction
Low solenoid air gap	Reset air gap (refer to Air Gap Adjustment)
Cycle Rate Cause	Cycle Rate Correction
Brake "jogging" exceeding coil cycle rate	Reduce cycle rate or consider alternate control method
Thermal capacity is being exceeded	Reduce cycle rate, use alternate control method or increase brake size
Alignment Cause	Alignment Correction
Brake endplate not concentric to motor C-Face	"Motor resister must be within
.004" on concentricity"	
Motor shaft runout is excessive	Must be within .002"; runout; consult motor manufacturer
Worn Parts Cause	Worn Parts Correction
Friction disc excessively worn (disc can wear to 1/2 original thickness or .093")	Replace friction discs
Endplate, stationary disc or pressure plate warped	Replaced warped or worn component
Linkages worn	Replace all worn components
Motor shaft endfloat excessive	Endfloat must not exceed .020"; consult motor manufacturer
Hub Cause	Hub Correction
Burr on hub interfering with disc "float"	File off burr
Set screw backed out and interfering with disc	Retighten set screw; use Loctite® 680 to help secure
Miscellaneous	Miscellaneous
Wiring is restricting disc pack movement	Reroute wiring
Excessive stop time (2 seconds or greater)	Increase brake size/torque or use alternate control method
High Ambient temperature (in excess of 110°F)	Reduce cycle rate or use alternate method of cooling

## ADJUSTMENTS

### MECHANICAL LOAD BRAKE

The mechanical load brake on Series Y80 YALE hoists is a pawl and ratchet "Weston" type automatic brake. The brake is not adjustable and requires only periodic inspection and occasional replacement of the friction washers.

### MOTOR BRAKE

Check brake adjustment after first 30 days of service and regularly thereafter during the six-month inspection procedure.

#### Installation and Service Instructions for 54,000 Series (rev. A) Manual Adjust Brakes.

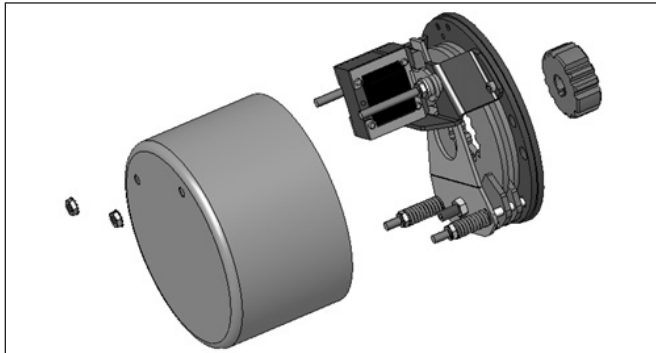

### IMPORTANT

Please read these instructions carefully before installing, operating, or servicing. Failure to comply with these instructions could cause injury to personnel and/or damage to property if the brake is installed or operated incorrectly.

### CAUTION

1. Installation and servicing must be made in compliance with all local safety codes including Occupational Safety and Health Act (OSHA). All wiring and electrical connections must comply with the National Electric Code (NEC) and local electric codes in effect.
2. To prevent an electrical hazard, disconnect power source before working on the brake. Lock disconnect in the off position and tag to prevent accidental application of power.

3. Be certain power source conforms to the requirements specified on the brake nameplate.
4. Be careful when touching the exterior of an operating brake. Allow sufficient time for brake to cool before disassembly. Surfaces may be hot enough to be painful or cause injury.
5. Do not operate brake with housing removed. All moving parts should be guarded.
6. After usage, the brake interior will contain burnt and degraded friction material dust. This dust must be removed before servicing or adjusting the brake.

DO NOT BLOW OFF DUST using an air hose. It is important to avoid dispersing dust into the air or inhaling it, as this may be dangerous to your health.

- a. Wear a filtered mask or a respirator while removing dust from the inside of a brake.
- b. Use a vacuum cleaner or a soft brush to remove dust from the brake. When brushing, avoid causing the dust to become airborne. Collect the dust in a container, such as a bag, which can be sealed off.

### GENERAL DESCRIPTION

This series brake is spring set, electrically released. These brakes will contain one or two friction discs driven by a hub mounted on the motor.

### OPERATING PRINCIPLE

When the brake coil is energized the lever arm retracts the spring force from the disc pack, allowing the friction disc to rotate with the hub and motor shaft. When power is removed the lever arm pushes down on the stationary disc and friction discs. The hub is held from rotating, and the load is held in place.

## **WARNING**

Do not release brake if there is a suspended load on the hoist hook.

Manually releasing the brake may allow a suspended load to fall, possibly causing damage, injury or death.

Always be certain any suspended load (which includes below the hook devices or attachments) are removed before servicing, adjusting or removing brake.

1 Place hub on motor shaft.

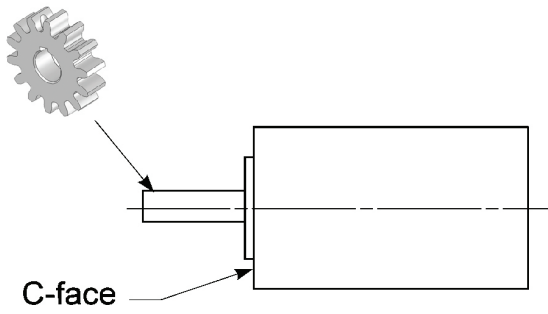

2 Apply Loctite 680 to set screws. Tighten set screws on motor shaft.

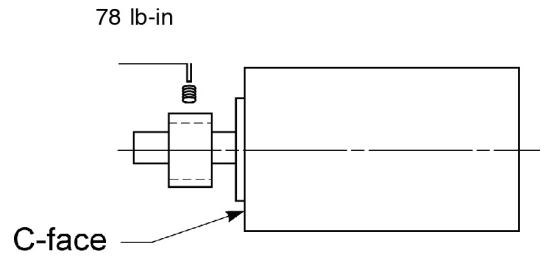

3 Remove brake housing and gasket.

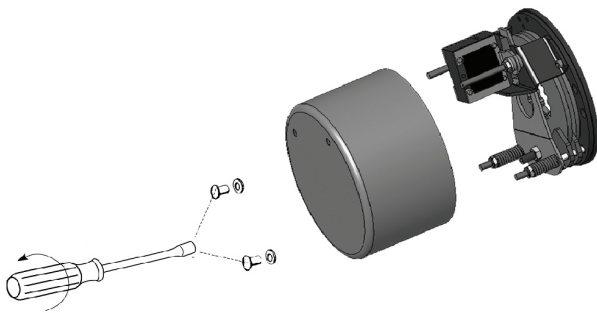

4 Align friction disc with splined hub and slide brake against motor face.

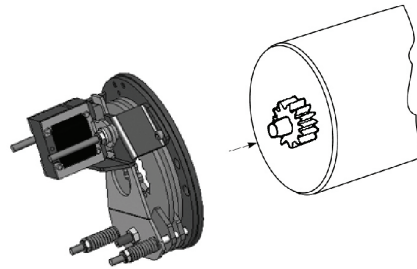

5 Insert mounting screws and tighten.

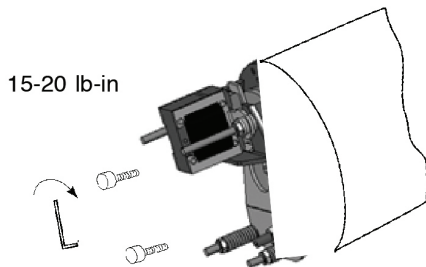

6 Connect coil leadwires to power supply. Refer to nameplate for voltage rating.\*  
**Caution:** Keep wiring away from pinch points and moving components.

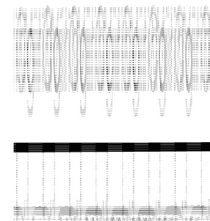

7 Replace brake housing and tighten to 8 lb-in.

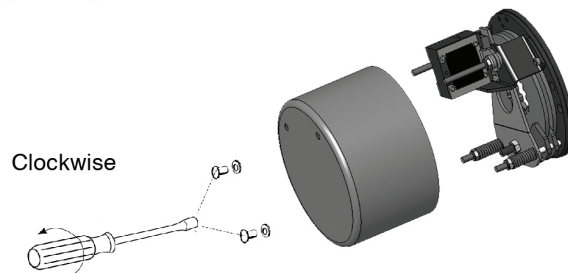

## AIR GAP ADJUSTMENT

Brake air gaps are factory adjusted to .100". As friction discs wear the air gap will increase. When the gap reaches .200" it will need to be readjusted to .100".

1. Loosen jam nut (10N).
2. Turn adjusting screw (10) CW until .100" gap is reached (see Fig. 1).
3. Retighten jamb nut.
4. Check air gap again...

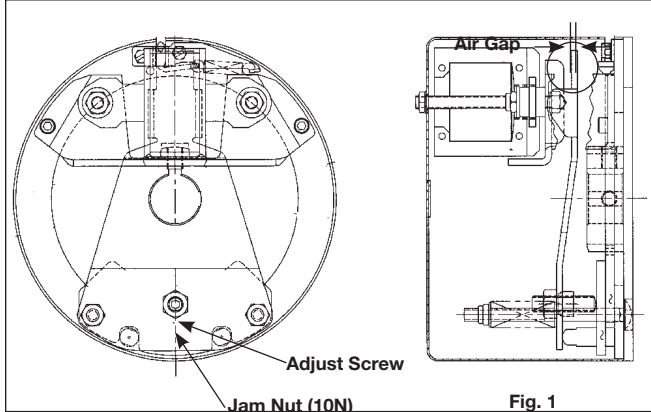

## TORQUE ADJUSTMENT

The brake is factory set for nominal rated torque. No further adjustment to increase torque may be made. The approximate compressed torque spring height is shown below. Torque reduction may not exceed 1 full turn in the CCW direction. Note that the spring measurement for the 6 and 9 lb-ft spring is from inside the shoulder washer.

Brake Torque (lb-ft)	Length "L" (in.)	Max Torque Reduction (ccw turn of torque nut)	% Reduction
6	1.286	1	25
9	1.188	1	15

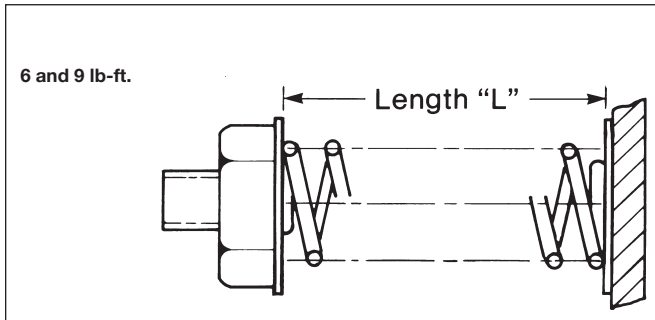

## FRICTION DISC REPLACEMENT

Friction disc(s) should be replaced when the wear area is 3/32" thick or less.

1. Remove the two brake mounting screws and lift the brake assembly from the hub / motor.
2. Remove the two support bracket screws (3s), and lift the brake and solenoid assembly (3) off the brake.
3. Lift the lever arm (17) forward and slide the friction disc(s) out of the brake assembly.
4. Insert new friction disc(s) under the stationary disc (5). If brake has two friction discs align the center spline holes with each other.
5. Align the brake and friction disc assembly on the hub (16) and slide onto the motor. Insert and tighten the two brake mounting screws (15-20 lb-ft).
6. Reposition the support bracket assembly (3) on the brake, and retighten the two support bracket screws (3s), (52 lbin).

**Note:** Air gap readjustment will be required after disc replacement.

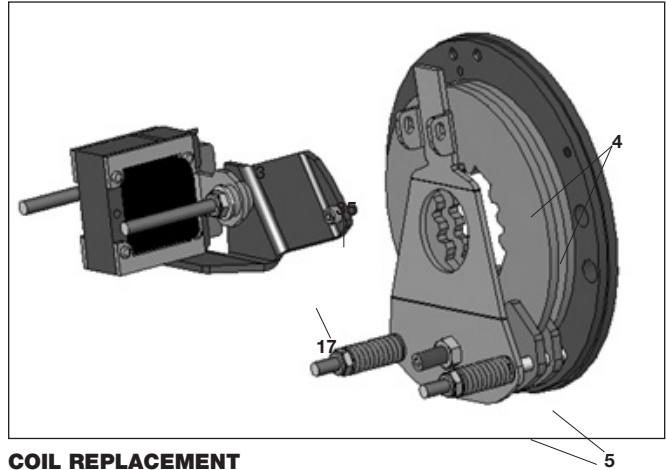

## COIL REPLACEMENT

1. Remove the two support bracket screws (3s), and lift the bracket and solenoid assembly (3) off the brake.
2. Remove the plunger guide (140) from the inside of the coil.
3. Remove the through-bolt (160) from the leadwire side of the coil by backing off the lock-nut (210). Slide the bolt, shock mount pads and flat washer out of the way.
4. Remove the coil (12) from the solenoid frame (79) by pushing down on the coil locking tab on the side opposite the leadwires. Push the coil out of the frame.
5. Insert the new coil into the solenoid frame in reverse of the steps of removal. Insert the new plunger guide (140) into the coil, locking tabs first.
6. Position a shock mount pad (150) on both sides of the solenoid mounting bracket, and reinsert the through-bolt (160) through the shock pads and bracket.
7. Slide a flat washer (170) over the bolt, and tighten the locknut down until the shock pads begin to flatten.
8. Position the solenoid and bracket assembly (3) over the plunger (29) and slide into place. Tighten the bracket mounting screws (3s) to 52 in-lb.
9. Reassemble brake motor by following steps 4-7 of the brake mounting procedure.

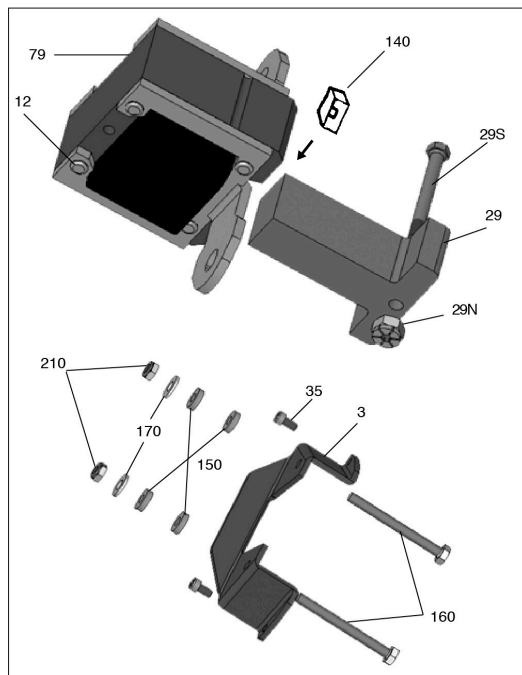



## SOLENOID REPLACEMENT

1. Remove the two support bracket screws (3s), and lift the bracket assembly (3) off the brake.
2. Remove the plunger guide (140) from the inside of the coil.
3. Remove both through-bolts (160) from the solenoid assembly (79).
4. Remove the coil (12) from the solenoid frame (79) by pushing down on the coil locking tab on the side opposite the leadwires. Push the coil out of the frame.
5. Insert the coil into the new solenoid frame in reverse of the steps of removal. Insert the new plunger guide (140) into the coil, locking tab first.
6. Position the new shock mount pad (150) on both sides of the solenoid mounting bracket, and reinsert the tap-bolts (160) through the shock pads and bracket.
7. Slide the flat washers (170) over the bolt, and tighten the locknut down until the shock pads begin to flatten.
8. Remove the plunger nut (29N) and screw (29S), and lift plunger (29) from lever arm (17). Install the new plunger to the lever arm using the new screw and nut provided. Tighten to 40 in-lb.
9. Position the solenoid and bracket assembly (3) over the plunger (29) and slide into place. Tighten the bracket mounting screws (3s) to 50 in-lb.
10. Reassemble brake to motor by following steps 4-7 of the brake mounting procedure.

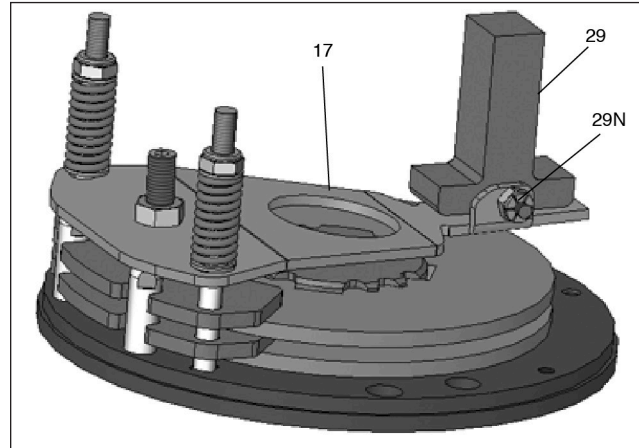

## BLOCK OPERATED LIMIT SWITCH

The block operated upper limit stop, furnished as standard equipment, is nonadjustable and designed to stop lower block at its high point of travel to guard against over-travel with possible damage to hoist. When high point is reached, limit stop switch automatically stops hook travel. If hook drifts upward slightly after stop switch is actuated, a reversing switch will close and automatically reverse direction of hook travel.

## SCREW-TYPE LIMIT SWITCH

This limit switch has a rotary screw driven by a gear reduction which is coupled to the end of the drum shaft. Adjustment discs operate the contacts of separate switches; one for the hoisting circuit and one for the lowering circuit. The switch assembly must be wired in accordance with the appropriate wiring diagram, which is packaged with hoist. Adjustment of this screw-type limit switch is accomplished as follows: (Refer to Figure 7-2).

### **WARNING**

Before attempting actual adjustments, be certain main power switch is **OFF** and locked in the open position.

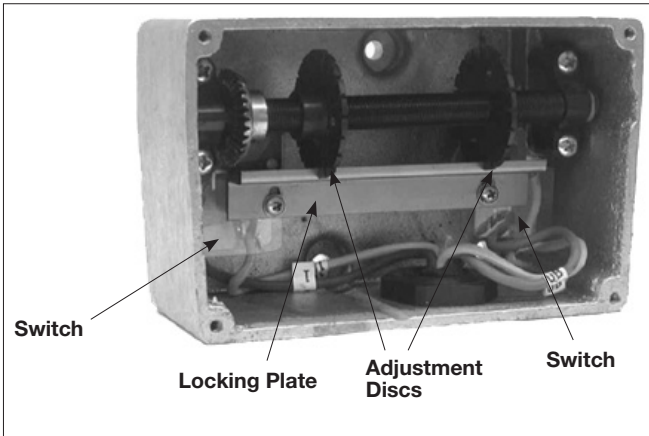

Figure 7-2. Screw-Type Limit Switch Adjustment (Wires not Shown for Clarity.)

- Remove four screws and lift off switch cover.
- Loosen locking plate screws. Slide locking plate away from adjustment discs.
- Turn proper adjustment disc (right for up, left for down) toward stich to reduce hook travel or away from switch to increase hook travel.
- Slide locking plate back into position ensuring slots on adjustment discs are fully engaged, tighten locking plate screws to 4 in-lbs.
- Replace cover.

### **WARNING**

Check limit switch operation carefully, without load, before placing hoist in service. If misadjusted, **SEVERE DAMAGE AND/OR A DROPPED LOAD COULD RESULT**. Allow 6" for hook drift in both directions. Never allow less than 1-1/2 complete wraps of rope on drum with hook in lowest position.

Provide a light film of NLGI No. 2 grease on bevel gear of limit switch.

## OVERLOAD CLUTCH ADJUSTMENT

When properly adjusted, the overload device is designed so that the hoist will lift its full rated load but will refuse to lift an excessive overload. The overload clutch is not externally adjustable. It is necessary to remove the overload clutch assembly from the hoist for proper adjustment. Therefore, it is strongly recommended that when adjustment and/or replacement parts are required, a YALE Authorized Repair Station be contacted. Consult your YALE Distributor for nearest Repair Station.

## **WIRING DIAGRAMS**

Wiring diagrams for YALE electric hoists have been omitted from this book because of many possible variations. This is due to different currents and types of electrical components used in their construction. A print of the correct wiring diagram for each hoist is furnished as a separate insert and shipped with hoist. We suggest you carefully file the wiring diagram with this book for future reference.

**WHEN ORDERING PARTS OR INFORMATION ON THIS EQUIPMENT, ALWAYS INCLUDE MODEL AND SERIAL NUMBER ON ORDER.**

## REPAIR PARTS LIST

### **WARNING**

Using "Commercial" or other manufacturer's parts to repair the YALE Hoists may cause load loss.

#### **TO AVOID INJURY:**

Use only YALE supplied replacement parts. Parts may look alike but YALE parts are made of specific materials or processed to achieve specific properties



### **ORDERING INSTRUCTIONS**

The following information must accompany all correspondence orders for replacement parts:

1. Hoist Model Number from identification plate.
2. Serial number of the hoist stamped below identification plate.
3. Voltage, phase, hertz from the identification plate.
4. Length of lift.
5. Part number of part from parts list.
6. Number of parts required.
7. Part name from parts list.

**NOTE: When ordering replacement parts, it is recommended that consideration be given to the need for also ordering such items as gaskets, fasteners, insulators, etc. These items may be damaged or lost during disassembly or just unfit for future use because of deterioration from age or service.**

### **GENERAL**

The parts lists and illustrations in this section of the manual, cover parts for all standard 800 YALE Electric Hoists. A typical hoist is shown as the basis for the exploded parts illustrations; therefore, certain variations may occur from the information given. For this reason, always give the Hoist Serial Number, Catalog Number, Motor Horsepower, Voltage, Phase, Frequency and Rated Load of Hoist when ordering parts.

Certain parts of your hoist will, in time, require replacement under normal wear conditions. It is suggested that these parts be purchased for your hoist as spares for future use. These

parts are indicated by a (†) symbol at the right side of the parts reference numbers.

**The numbers assigned to the parts of our various assemblies in our parts list are not the part numbers used in manufacturing the part. They are identification numbers, that when given with the model number, permit us to identify, select or manufacture, and ship the correct part needed.**

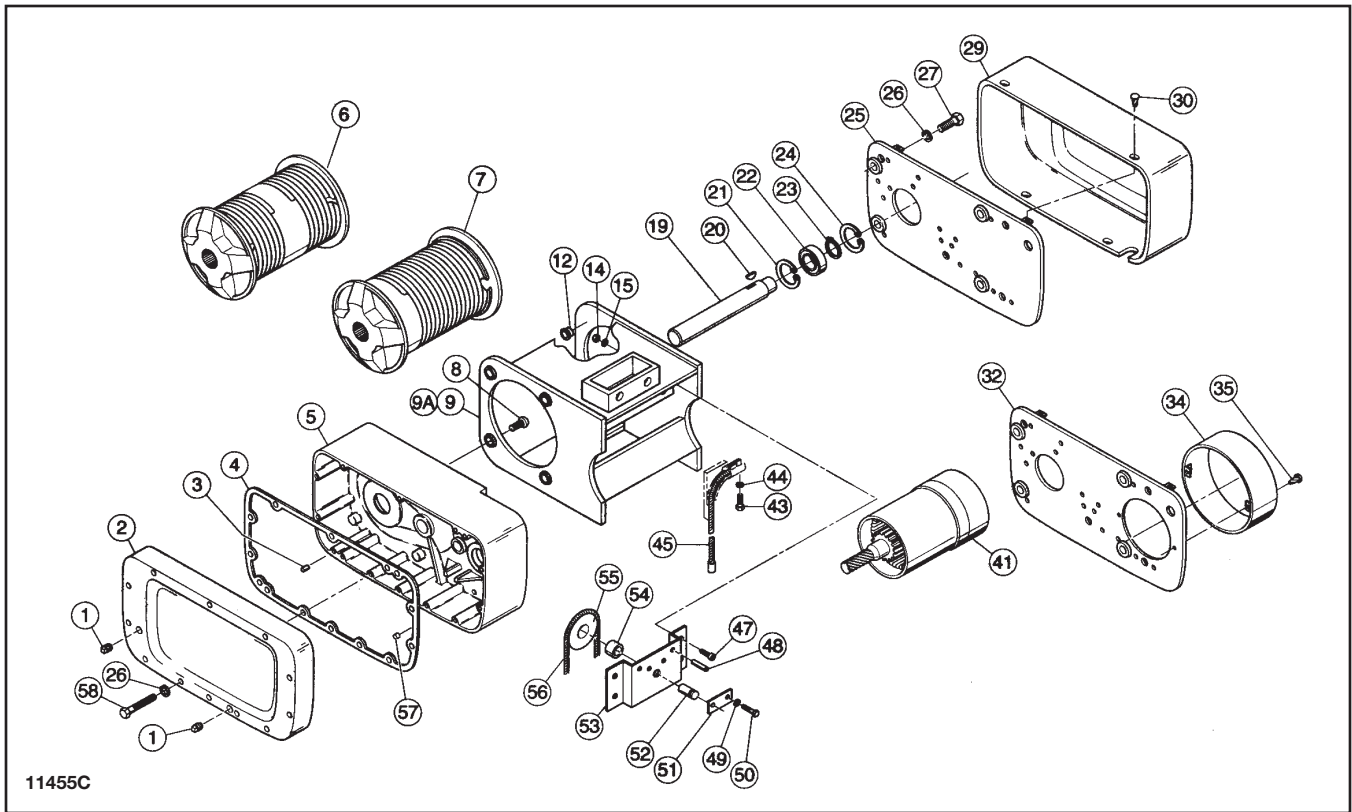

Figure 9-1. Frame, Gearcase and External Parts

Ref. No.	Item Number	Part Name	Quantity Required
1	800-197	Plug - Oil Level 2	
2	800-192	Cover & Bearing Assembly - Gearcase 1	
3	800-105	Dowel 2	
4†	800-106	Gasket - Gearcase 1	
5	800-107	Gearcase & Bearing Assembly 1	
6		Drum & Hub Assembly (Double Reeved Models) 1 1/2 & 1 Ton (3/6" Dia. Rope)	
	800-109	18' Lift	
	800-111	34' Lift	
	800-2100	47' Lift	
	800-108	2 Ton (1/4" Dia. Rope) 14' Lift	
	800-110	25' Lift	
	800-2101	36' Lift	
7		Drum & Hub Assembly (Single Reeved Models) 1 1/2 & 1 Ton (1/4" Dia. Rope)	
	800-113	25' Lift	
	800-115	50' Lift	
	800-112	2 Ton (5/16" Dia. Rope) 20' Lift	
	800-114	40' Lift	
	800-2102	3 Ton (5/16" Dia. Rope) 30' Lift	
	800-2103	45' Lift	
	800-2104	5 Ton (5/16" Dia. Rope) 20' Lift	
	800-2105	30' Lift	
8	800-116	Screw - Hex, Socket Button Head - Self-Locking 4	

Ref. No.	Item Number	Part Name	Quantity Required
9		Frame Assembly (Single Reeved Models) 1 1/2, 1 & 2 Ton	
	800-117	Short Frame	
	800-118	Long Frame	
	800-2106	3 Ton	
	800-2107	First Extension Second Extension	
	800-2108	5 Ton	
	800-2109	First Extension Second Extension	
9A		Frame Assembly (Double Reeved Models) 1/2, 1 & 2 Ton	1
	800-2110	Short Frame	
	800-2111	Long Frame	
	800-2112	First Extension	
12	800-121	Closure - 1/2" Plug	3
14	800-124	Nut - Hex (Double Reeved Models)	4
15	800-125	Lockwasher (Double Reeved Models)	4
19		Shaft - Extension, Drum	1
	800-130	Short Frame	
	800-131	Long Frame	
	800-2113	First Extension	
	800-2114	Second Extension	
20	800-132	Key - Woodruff ("Hi-Pro" Type)	1
21	800-133	Ring - Retaining, Hub (Internal)	1
22†	800-134	Bearing - Drum Shaft	1
23	800-135	Ring - Retaining, External	1

Ref. No.	Item Number	Part Name	Quantity Required
24	800-136	Ring - Retaining, Beveled Hub (Internal)	1
25	800-137a	Plate Assembly - Base	1
26	800-138	Lockwasher	16
27	800-139	Screw - Hex Socket Head Cap	4
29	800-194c	Cover Assembly - Electrical	1
30	800-2121	Screw - Self-Tapping	2
32	800-146a	Plate Assembly - Base (Short Frame)	1
34	800-2122	Shell - Brake, Short Frame	1
35	800-149	Screw - Self-Tapping	2
41	See Fig. 9-3 & Fig. 9-4	Motor & Brake	1
43	800-155	Screw - Hex Socket Head	1
44	800-156	Lockwasher	1
45†		Rope & Thimble Assembly (Single Reeved Models) 1/2 & 1 Ton (1/4" Dia. Rope)	1
	800-158	25' Lift	
	800-161	50' Lift	
		2 Ton (5/16" Dia. Rope)	
	800-157	20' Lift	
	800-160	40' Lift	
		3 Ton (5/16" Dia. Rope)	
	800-2115	30' Lift	
	800-2116	45' Lift	
		5 Ton (5/16" Dia. Rope)	

Ref. No.	Item Number	Part Name	Quantity Required
	800-2117	20' Lift	
	800-2118	30' Lift	
47	800-164	Screw - Hex Socket	4
48	800-165	Head Roll Pin	2
49	800-166	Lockwasher	2
50	800-167	Screw - Hex Head Cap	2
51	800-168	Key Plate	1
52	800-169	Shaft - Sheave (Double Reeved Models)	1
53	800-170	Bracket, Sheave (Double Reeved Models)	1
54†	800-171	Bearing, Sheave (Double Reeved Models)	1
55†	800-172	Sheave Assembly, Upper (Double Reeved Models) Includes Bearing	1
56†		Rope & Thimble Assembly (Double Reeved Models) 1/2 & 1 Ton (3/16" Dia. Rope)	
	800-174	18' Lift	
	800-176	34' Lift	
	800-2119	47' Lift	
		2 Ton (1/4" Dia. Rope)	
	800-173	14' Lift	
	800-175	25' Lift	
	800-2120	36' Lift	
57	800-177	Plug, Pin	
58	800-178	Bolt, Hex Head	
61	800-196	Label, Capacity (Specify Capacity)	

† Recommended spares

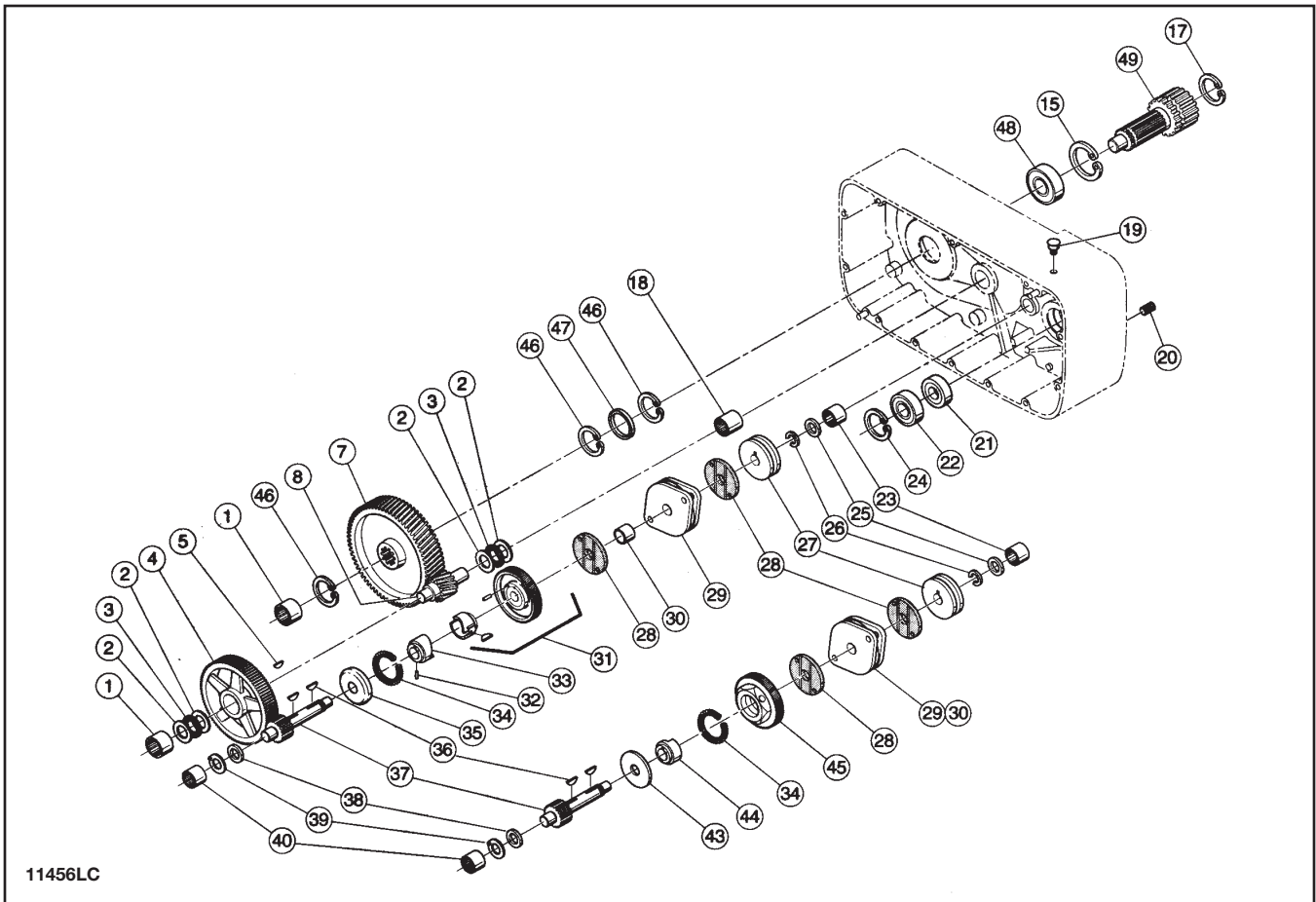

Figure 9-2. Gearing and Load Brake Parts

Ref. No.	Item Number	Part Name	Quantity Required	Ref. No.	Item Number	Part Name	Quantity Required
1†	800-201	Bearing Assembly - Needle, Intermediate & Drum Gear Shaft	2	19	800-269	Cover - Oil Hole	1
2†	800-202	Race - Thrust Bearing	4	20	800-224	Pipe Plug - Hex Socket	1
3†	800-203	Bearing Assembly - Needle Thrust	2	21†	800-225	Oil Seal - Motor Shaft	1
4		Gear - Intermediate	1	22†	800-226	Bearing Assembly - Ball, Motor Shaft	1
	800-204	104 Teeth		23†	800-227	Bearing Assembly - Needle, Load Brake Shaft	1
	800-205	109 Teeth		24	800-228	Ring - Retaining, Motor Shaft Bearing	1
	800-266	103 Teeth		25	800-229	Washer - Thrust (Steel)	1
	800-206	90 Teeth				Brake Assembly - Load, Complete (Includes Items 26 thru 37)	1
	800-2205A	107 Teeth			800-230	23 Teeth	
5	800-207	Key - Woodruff	1		800-231	36 Teeth	
7		Gear - Drum	1		800-267	24 Teeth	
	800-209	71 Teeth			800-232	18 Teeth	
	800-210	61 Teeth			800-2232A	20 Teeth	
	800-2209	71 Teeth		26	800-233	Ring - Retaining, Brake Flange	1
8		Shaft - Intermediate Gear	1	27	800-234	Flange - Load Brake	1
	800-211	14 Teeth		28*	800-235	Washer - Friction	2
	800-212	24 Teeth		29	800-236	Pawl & Ratchet Assembly - Load Brake (Available Only As An Assembly)	1
	800-2211	14 Teeth		30	800-237	Bushing - Ratchet	1
15	800-219	Ring - Retaining, Drum Shaft Bearing	1	31	800-238	Gear & Center Assembly	1
17	800-221	Ring - Retaining	1	32	800-239	Pin - Groove	2
18†	800-222	Bearing Assembly - Roller, Intermediate Shaft	1				

Ref. No.	Item Number	Part Name	Quantity Required
33†	800-240	Cam - Load Brake	1
34†	800-241	Spring - Load Brake	1
35	800-242	Retainer - Spring, Load Brake	1
36	800-243	Key - Woodruff	2
37		Shaft & Integral Pinion - Load Brake	1
	800-244	23 Teeth	
	800-245	36 Teeth	
	800-268	24 Teeth	
	800-246	18 Teeth	
	800-2246A	20 Teeth	
38†	800-247	Washer - Thrust (Used With 800-246 Only)	1
39†	800-248	Washer - Thrust (Bronze)	1
40†	800-249	Bearing Assembly - Needle, Load Brake Shaft	1
*	800-250	Load Brake - Clutch Assembly With Bearings (Complete)	1
**	800-251	Load Brake - Clutch Assembly (Includes Items 26 thru 30, 34, 36 thru 38 and 43 thru 45)	1
43	800-254	Spring Retainer	} Available only as part of 0-250 or 800-251 above
44	800-253	Brake Gear, Center	
45	800-252	Clutch Assembly	
46	800-260	Ring - Retaining	3
47	800-263	Oil Seal - Drum Shaft	1
48	800-261	Bearing Assembly - Ball, Drum Shaft	1
49	800-262	Shaft - Drum	1

† Recommended spares.

\* Recommended Replacement Kit for Load Brake Clutch (Complete).

\*\* Replacement Complete, Less Bearings and Thrust Washers.



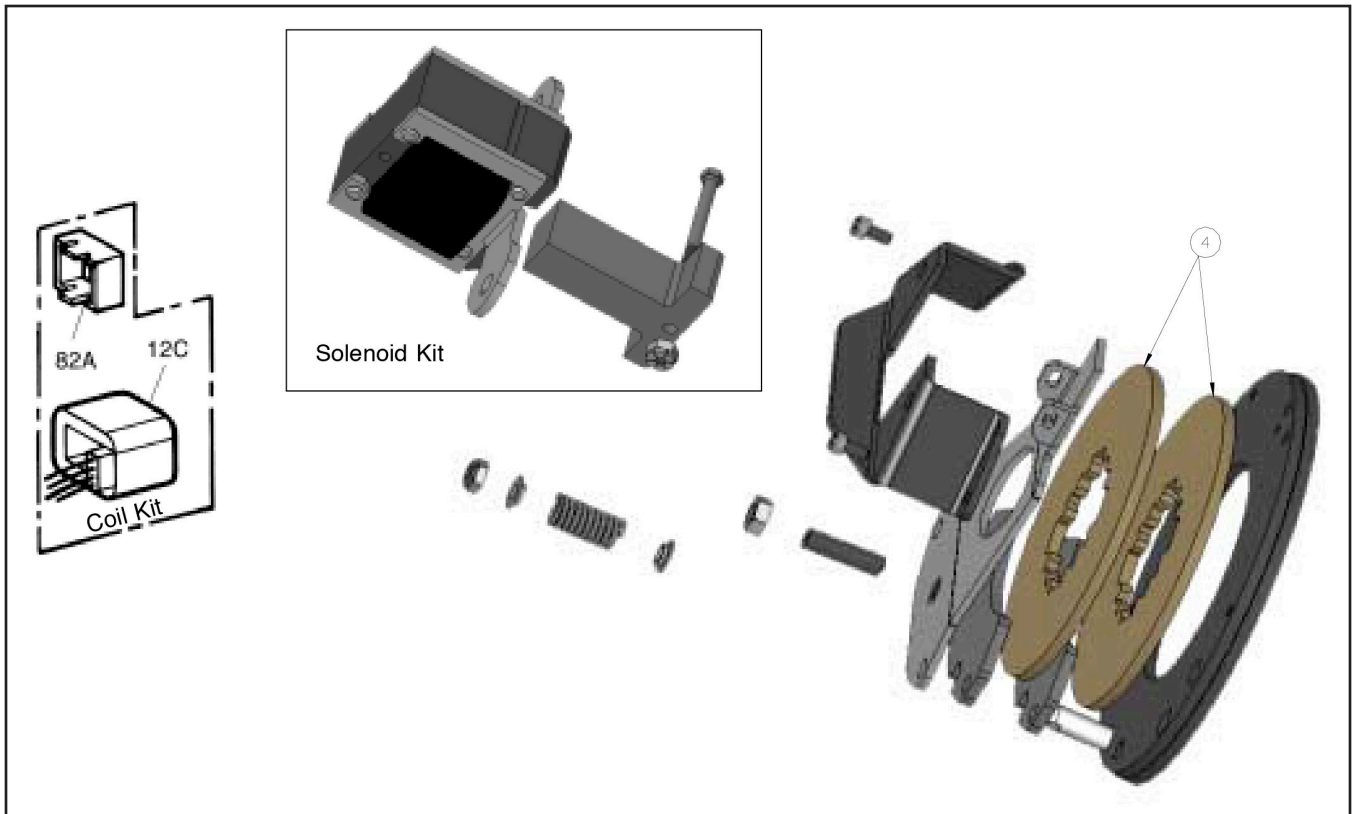

Figure 9-3. Hoist Motor Brake

Part No.	Motor HP	Motor RPM	Voltage	Coil Kit	Brake Torque ft. - lbs.
800-4047 800-4048	1	1800	208-230/460 575	800-5001 800-5002	6
800-2425 800-2426	2	1800	208-230/460 575	800-2427 800-2428	9
800-2425 800-2426	3 & 4	3600	208-230/460 575	800-2427 800-2428	9

Ref. No.	Item Number	Part Name
	800-5004	Solenoid Kit
4	800-5005	Friction Disc
	800-5006	Brake Hub (not shown)
	800-5007	Brake Cover - Partial Cover (short frame only)
	800-5008	Brake Cover - Primer (not shown - except short frame)

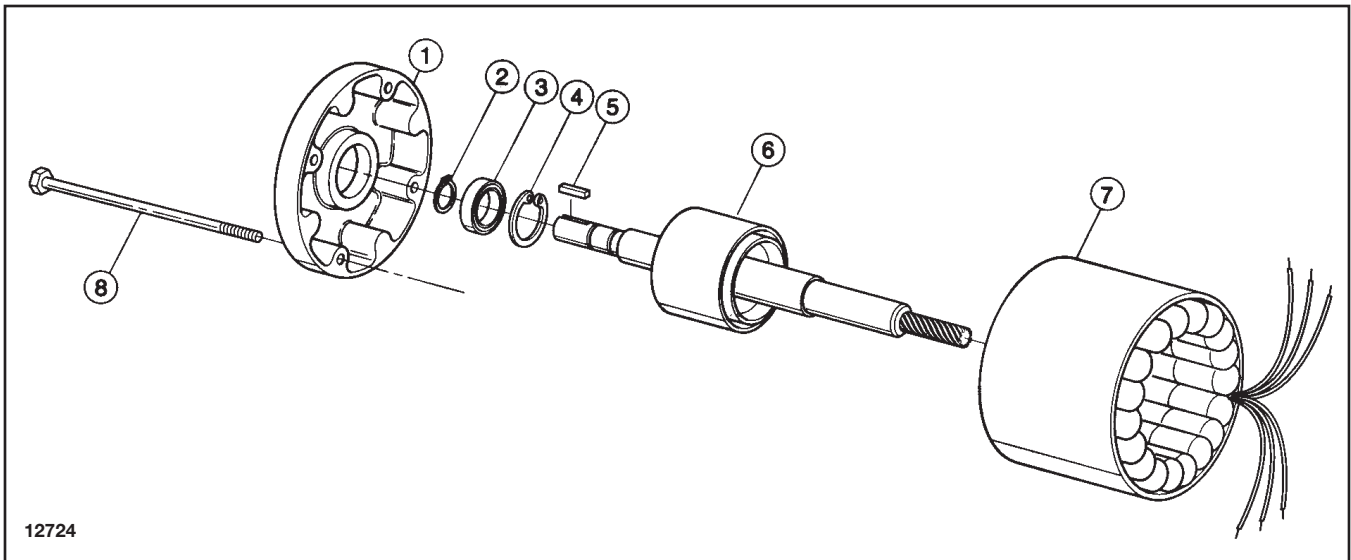
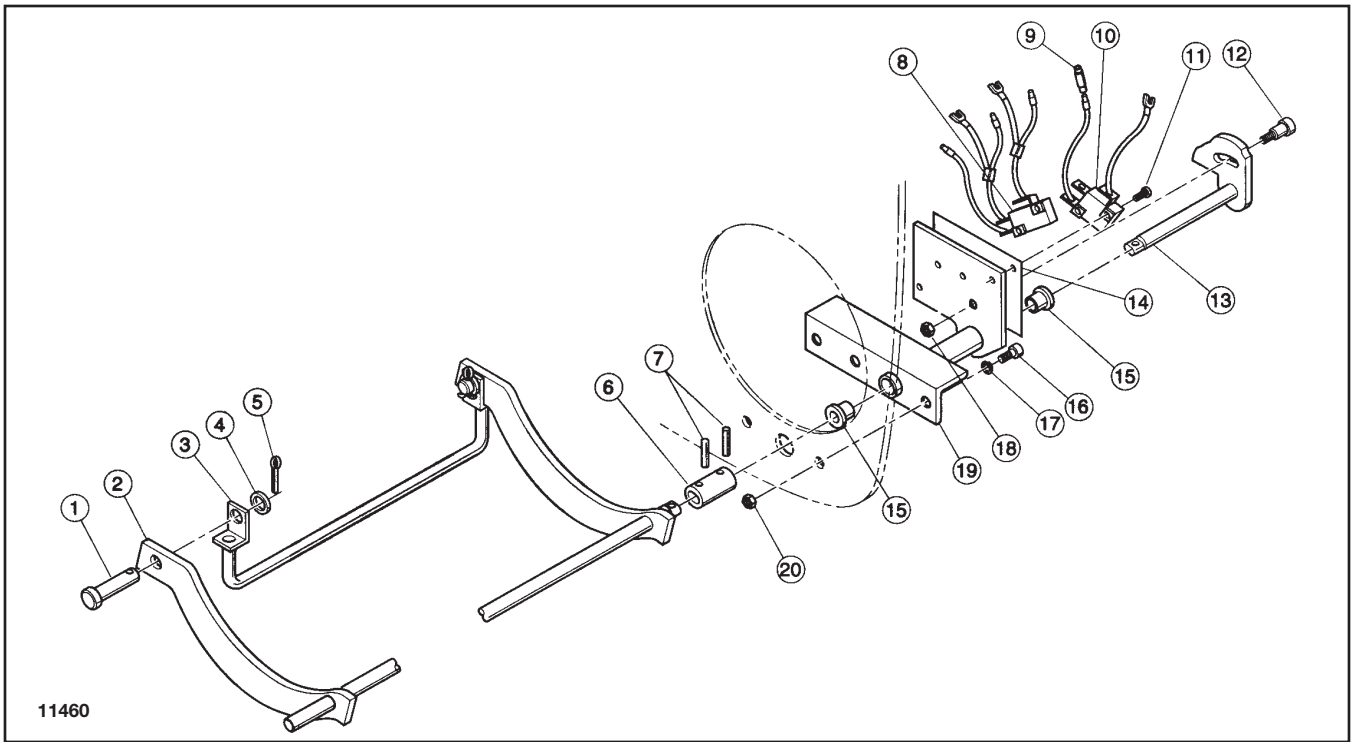

Figure 9-4. Three Phase Motor Assembly

Ref. No.	Item Number	Part Name	Quantity Required
		Motor Assembly (Includes Ref. Nos. 1 thru 8) 1 Horsepower (1 Speed)	1
	800-1301	200 Volt	
	800-1302	230/460 Volt	
	800-1303	575 Volt	
		2 Horsepower (1 Speed)	
	800-1304	200 Volt	
	800-1305	230/460 Volt	
	800-1306	575 Volt	
		4 Horsepower (1 Speed)	
	800-1307	200 Volt	
	800-1308	230/460 Volt	
	800-1309	575 Volt	
		1 - 1/3 Horsepower (2 Speed)	
	800-1310	200 Volt	
	800-1311	230 Volt	
	800-1312	460 Volt	
	800-1313	575 Volt	
		2 - 2/3 Horsepower (2 Speed)	
	800-1314	200 Volt	
	800-1315	230 Volt	
	800-1316	460 Volt	
	800-1317	575 Volt	

Ref. No.	Item Number	Part Name	Quantity Required
		3 - 1 Horsepower (2 Speed)	
	800-1318	200 Volt	
	800-1319	230 Volt	
	800-1320	460 Volt	
	800-1321	575 Volt	
		4 - 2 Horsepower (2 Speed)	
	800-1322	200 Volt	
	800-1323	230 Volt	
	800-1324	460 Volt	
	800-1325	575 Volt	
1	*	Bell - End	1
2	*	Ring - Retaining	1
3	*	Bearing - Ball	1
4	*	Ring - Retaining	1
5	*	Key - Brake	1
6	*	Rotor and Shaft Assembly	1
7	*	Stator Assembly	1
8	*	Bolt - Motor	4

\* Furnished only as part of motor assembly.



11460

Figure 9-5. Upper Limit Switch Parts

Ref. No.	Item Number	Part Name	Quantity Required
1	800-501	Pin - Pivot	2
2		Arm - Lever	1
	800-502	Short Frame	
	800-503	Long Frame	
	800-526	First Extension	
	800-527	Second Extension	
3		Lever - Floating	1
	800-504	Short Frame	
	800-505	Long Frame	
	800-528	First Extension	
	800-529	Second Extension	
4	800-506	Washer	2
5	800-507	Pin - Cotter	2
6	800-525	Coupling	1
7	800-509	Pin - Roll	2

Ref. No.	Item Number	Part Name	Quantity Required
8†	800-510	Switch Assembly - Limit, Reversing (Includes Wire Leads)	1
9	800-511	Connector - Wire	3
10†	800-512	Switch Assembly - Limit, Stop (Includes Wire Leads)	1
11	800-513	Screw - Round Head	4
12	800-514	Screw - Socket Head Shoulder	1
13	800-515	Shaft & Cam Assembly	1
14	800-516	Insulator - Limit Switch	1
15	800-517	Bearing - Nylon	2
16	800-518	Screw - Socket Head Cap	2
17	800-519	Lockwasher	2
18	800-520	Nut - Lock	1
19	800-521	Bracket Assembly - Mounting	1
20	800-522	Nut - Hex	2

† Recommended spares

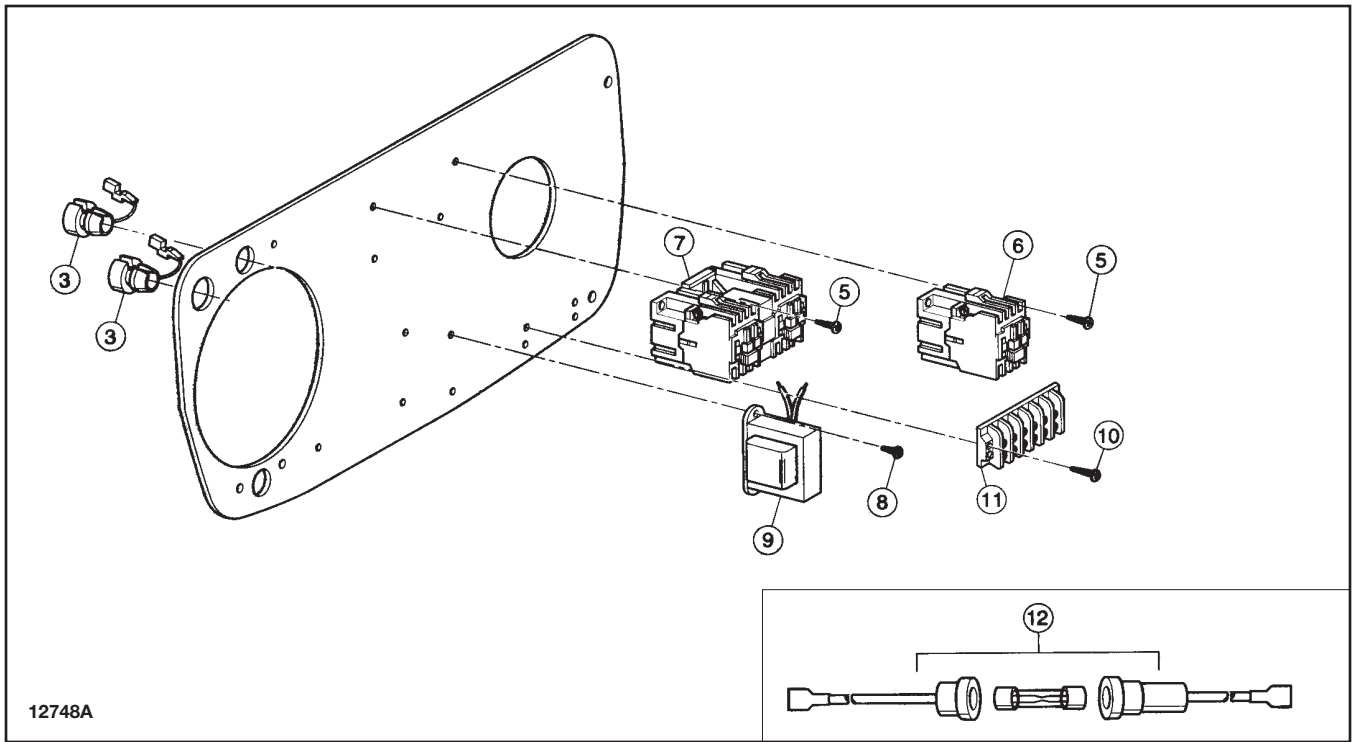
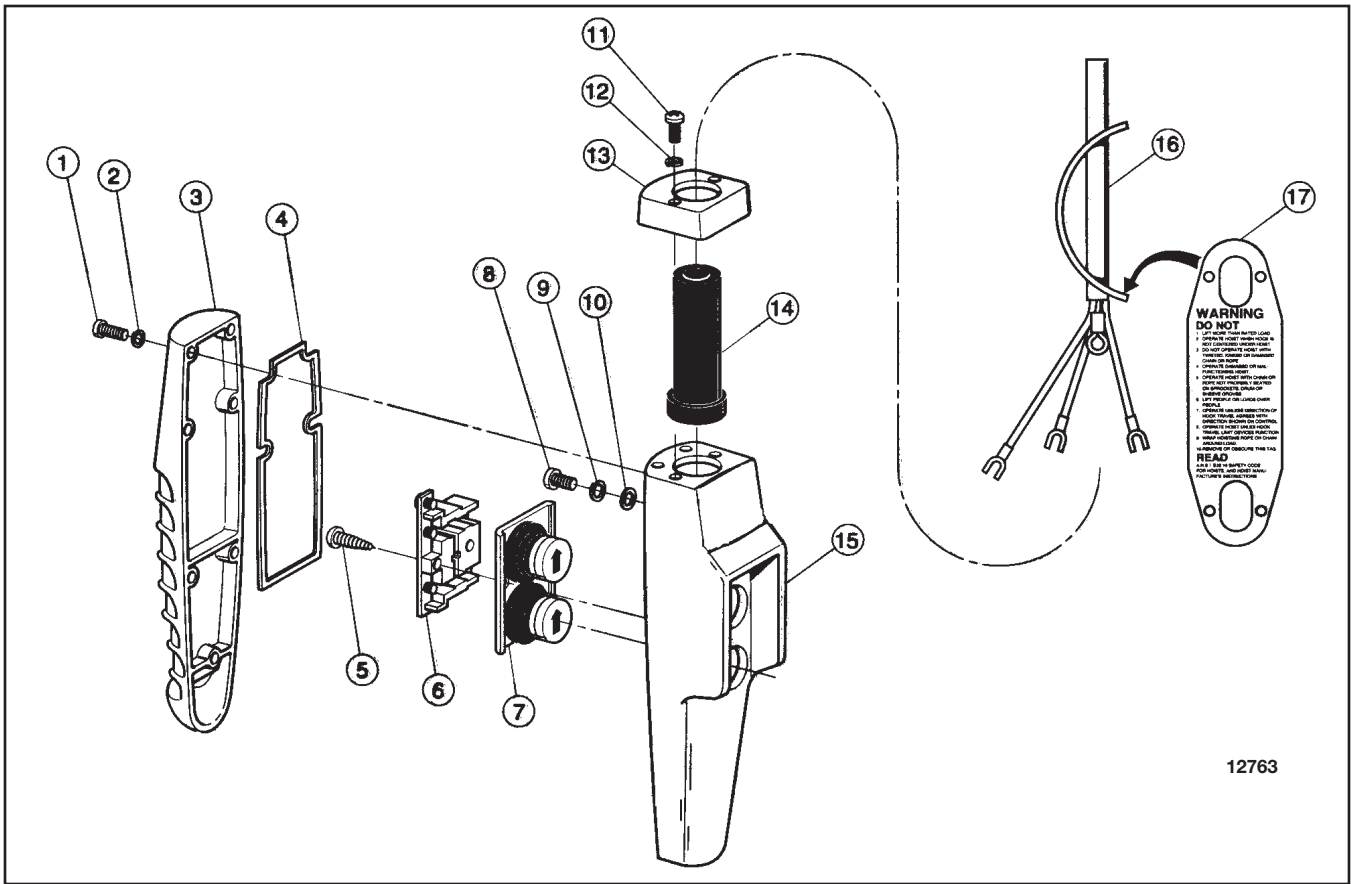

Figure 9-6. Electrical Control Equipment

Ref. No.	Item Number	Part Name	Quantity Required
3	800-670	Cord Grip - Conductor	2
5	800-654	Screw - Self-Tapping	4
6†	800-655	Contactor - Two Speed	1
7†	800-656	Contactor	1
8	800-657	Screw - Self-Tapping	2
9†	800-671	Transformer	1
10	800-663	Screw - Self-Tapping	4
11†	800-672	Terminal Board (Reconnectable Hoist Only)	1
12	800-673	Fuse, Fuse Holder and Wire Assembly	1
	800-674	Fuse Only (2A, 300V)	1

† Recommended spares



12763

Figure 9-7. Push Button Station and Conductor Cable Assembly. Single Speed Hoists

Ref. No.	Item Number	Part Name	Quantity Required
	800-2701	Push Button Station and Conductor Cable Assembly (Includes Ref. Nos. 1 thru 17)	1
	800-2702	Push Button Station (Includes Ref. Nos. 1 thru 15)	1
1	*	Type 1 Pan Head Machine Screw (M 3.5 x 0.6 x 12 PIttd.)	7
2	*	Lockwasher (M 3.5 PIttd.)	7
3	*	Rear Cover	1
4	800-2703	Gasket	1
5	*	Type 1 Pan Head Thread Cutting Screw (M 4 x 15 PIttd.)	2
6	800-2704	Contact Assembly	1
7	800-2705	Button Assembly	1

Ref. No.	Item Number	Part Name	Quantity Required
8	*	Type 1 Pan Head Machine Screw (M 6 x 1 x 12 PIttd.)	1
9	*	Lockwasher (M 6 PIttd.)	1
10	*	Plain Washer (M 6 PIttd.)	1
11	*	Type 1 Pan Head Machine Screw (M 3.5 x 1 x 14 PIttd.)	2
12	*	Lockwasher (M 3.5 PIttd.)	2
13	*	Housing Cap	1
14	800-2706	Grommet	1
15	*	Housing	1
16	800-2707	Conductor Cable Assembly	1
17	800-2708	Plastic Warning Tag	1

\* Not available separately. Order Push Button Station

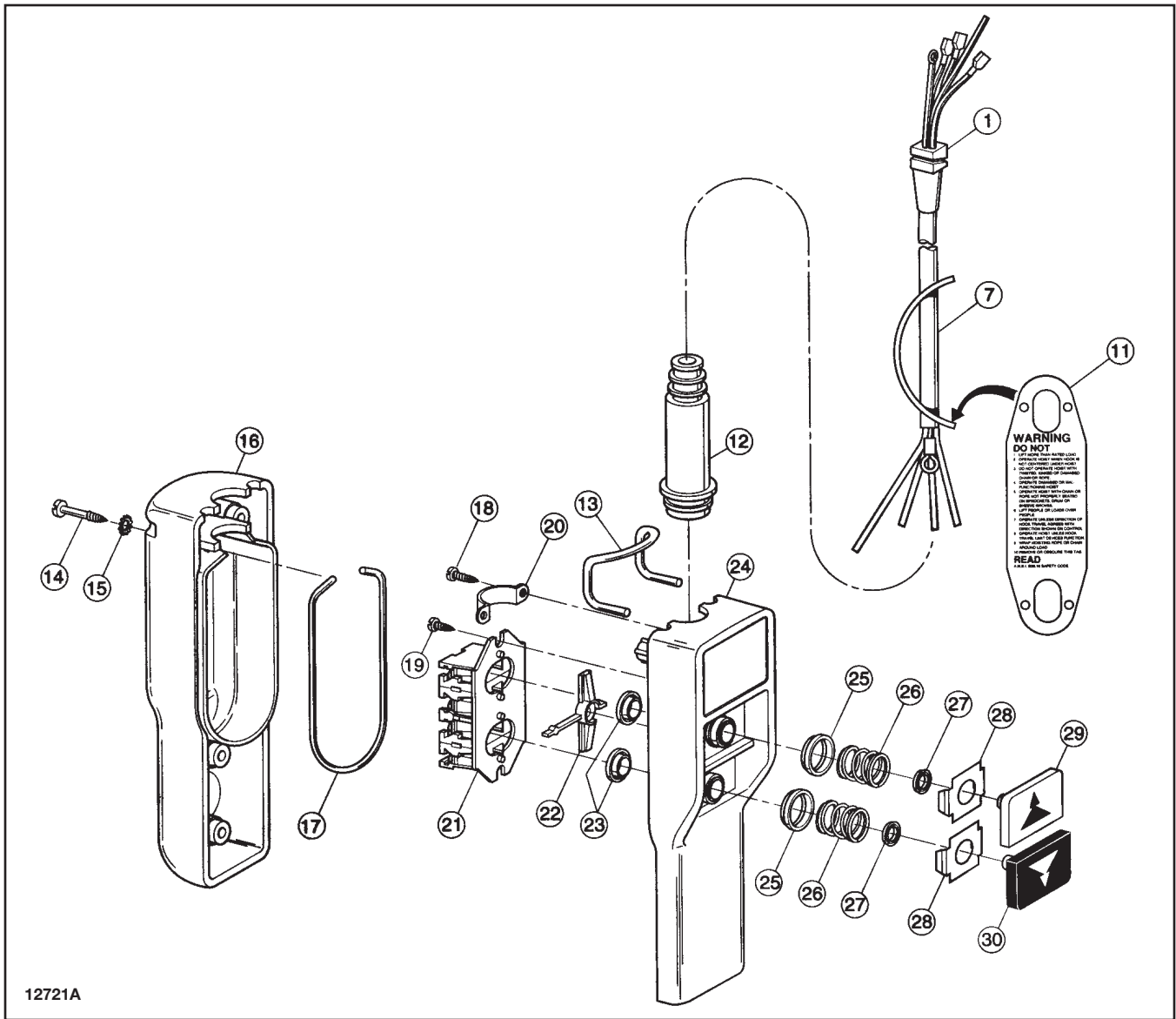

12721A

Figure 9-8. Push Button Station and Conductor Cable Assembly. (Two Speed Hoists Only)

Ref. No.	Item Number	Part Name	Quantity Required
	BH-4027	Push Button Station and Conductor Cable Assembly (Includes Ref. Nos. 1 thru 30)	1
1	BH-1981	Grommet	1
2	BH-1982	Conductor Cable	1
3	BH-1971	Operator Warning Label	1
	BH-4029	Push Button Station (Includes Ref. Nos. 12 thru 30)	1
4	BH-4030	Control Station Grommet	1
5	*	Control Station Hardware	4
6	*	Control Station Housing	4
7	BH-3403	Gasket	1
8	BH-4028	Button and Control Assembly	1
		Contact Block	2
		Contact Block	2

\* Not available separately. Order Push Button Station.

\*\* Not available separately. Order Push Button Assembly.

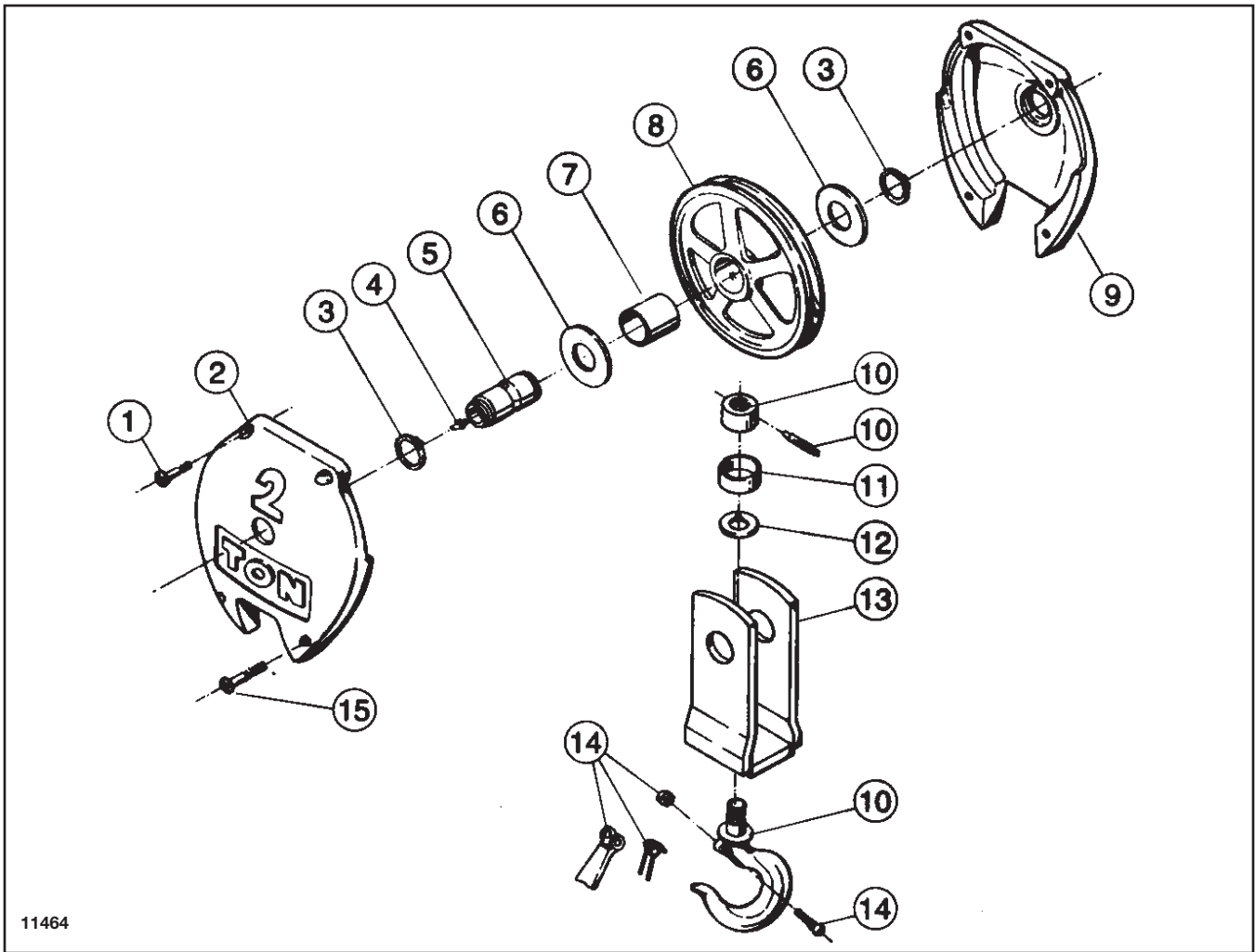

11464

Figure 9-9. Lower Block Assembly - Two Parts Rope, Single Reeved

Ref. No.	Item Number	Part Name	Quantity Required
	800-801	Block Assembly - Lower, Complete, 2 Ton	1
	800-802	Block Assembly - Lower, Complete, 1 Ton	1
	800-803	Block Assembly - Lower, Complete, 1/2 Ton	1
1	800-804	Screw - Flat Head, Self-Threading	2
2	800-805	Cover - 2 Ton	1
	800-806	Cover - 1 Ton	1
	800-807	Cover - 1/2 Ton	1
3	800-808	Ring - Retaining, 2 Ton	2
	800-809	Ring - Retaining, 1/2 & 1 Ton	2
4	800-810	Lube Fitting	1
5	800-811	Pin - Sheave, 2 Ton	1
	800-812	Pin - Sheave, 1/2 & 1 Ton	1
6	800-813	Spacers - 2 Ton	2
	800-814	Spacers - 1/2 Ton & 1 Ton	2
†	800-815	Sheave Assembly - 2 Ton (Consists of Items 7 and 8)	1
7	800-816	Bearing	1
8	800-817	Sheave	1

Ref. No.	Item Number	Part Name	Quantity Required
†	800-818	Sheave Assembly - 1/2 & 1 Ton (Consists of Items 7 and 8)	1
7	800-819	Bearing	1
8	800-820	Sheave	1
9	800-821	Cover - Lower Block, 2 Ton	1
	800-822	Cover - Lower Block, 1 Ton	1
	800-823	Cover - Lower Block, 1/2 Ton	1
10†	800-824	Hook Assembly - (Consists of Hook, Nut & Grooved Pin), 2 Ton	1
†	800-825	Hook Assembly - (Consists of Hook, Nut & Grooved Pin), 1/2 & 1 Ton	1
11	800-826	Shroud - Thrust Bearing, 2 Ton	1
	800-827	Shroud - Thrust Bearing, 1/2 & 1 Ton	1
12†	800-828	Bearing Washer - Thrust, 2 Ton	1
†	800-829	Bearing Washer - Thrust, 1/2 & 1 Ton	1
13	800-830	Body - Lower Block, 2 Ton	1
	800-831	Body - Lower Block, 1/2 & 1 Ton	1
14	800-832	*Safety Hook Latch Kit - 2 Ton	1
	800-833	*Safety Hook Latch Kit - 1/2 & 1 Ton	1
15	800-834	Screw - Flat Head, Self-Threading	2

† Recommended Spares

\* Furnished as standard with hook

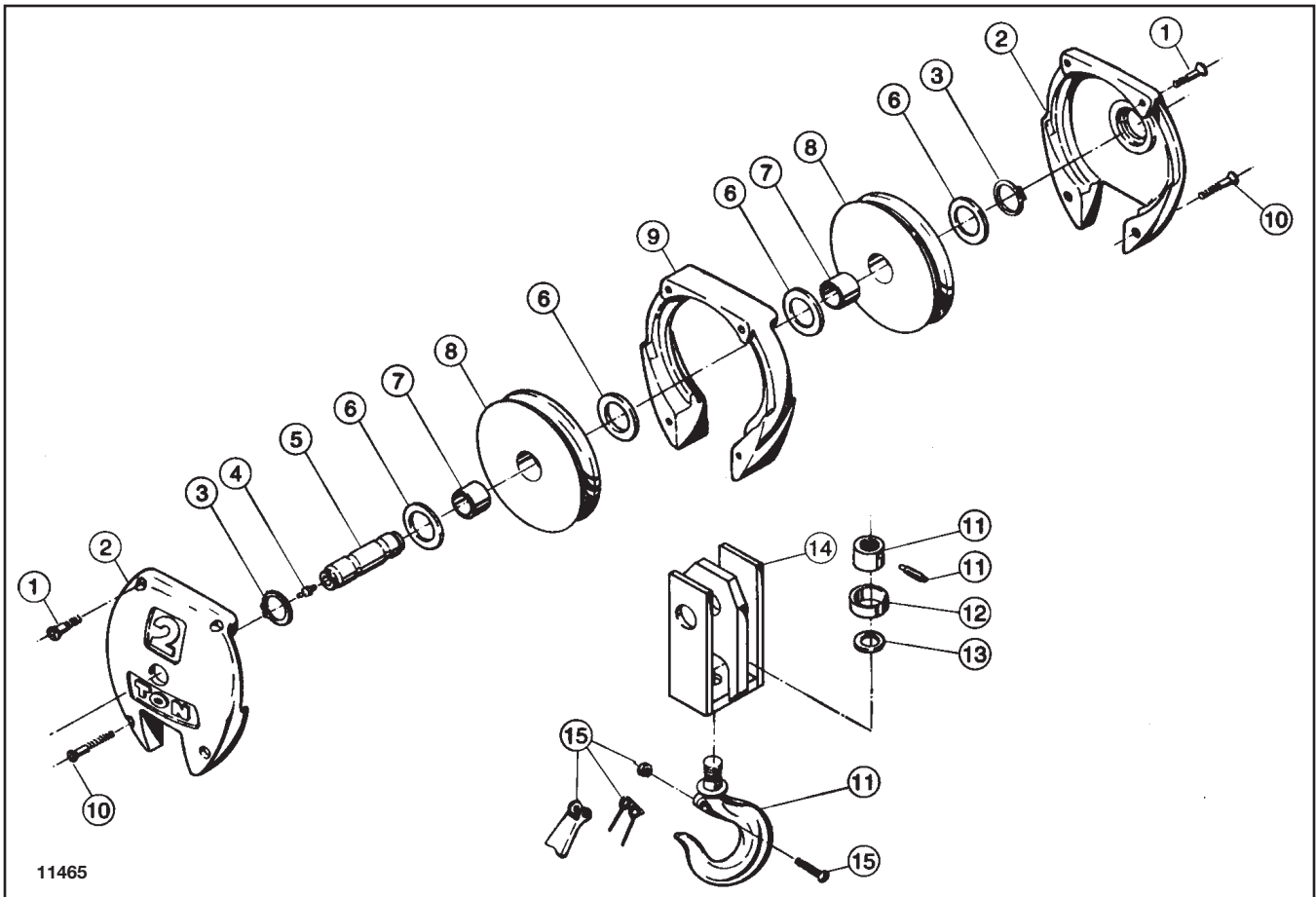

Figure 9-10. Lower Block Assembly—Two Parts Double Reeved

Ref. No.	Item Number	Part Name	Quantity Required
	800-851	Block Assembly - Lower, Complete, 2 Ton	1
	800-852	Block Assembly - Lower, Complete, 1 Ton	1
	800-853	Block Assembly - Lower, Complete, 1/2 Ton	1
1	800-804	Screw - Flat Heads Self-Threading	4
2	800-854	Cover - Lower Block, 2 Ton	2
	800-806	Cover - Lower Block, 1 Ton	2
	800-807	Cover - Lower Block, 1/2 Ton	2
3	800-809	Ring - Retaining	2
4	800-810	Fitting - Lube	1
5	800-855	Pin - Sheave	1
6	800-814	Spacer	4
†	800-818	Sheave Assembly - (Consists of Items 7 and 8)	2
7	800-819	Bearing	2

Ref. No.	Item Number	Part Name	Quantity Required
8	800-820	Sheave	2
9	800-856	Cover - Intermediate	1
10	800-834	Screw - Flat Head, Self-Threading	4
11†	800-824	Hook Assembly - (Consists of Hook, Nut & Grooved Pin), 2 Ton	1
†	800-825	Hook Assembly - (Consists of Hook, Nut & Grooved Pin), 1/2 & 1 Ton	1
12	800-826	Shroud - Thrust Bearing, 2 Ton	1
	800-827	Shroud - Thrust Bearing, 1/2 & 1 Ton	1
13†	800-828	Bearing - Thrust, 2 Ton	1
†	800-829	Bearing - Thrust, 1/2 & 1 Ton	1
14	800-857	Body - Lower Block, 2 Ton	1
	800-858	Body - Lower Block, 1/2 & 1 Ton	1
15	800-832	*Safety Hook Latch Assembly - 2 Ton	1
	800-833	*Safety Hook Latch Assembly - 1/2 & 1 Ton	1

† Recommended Spares

\* Furnished as standard with hook



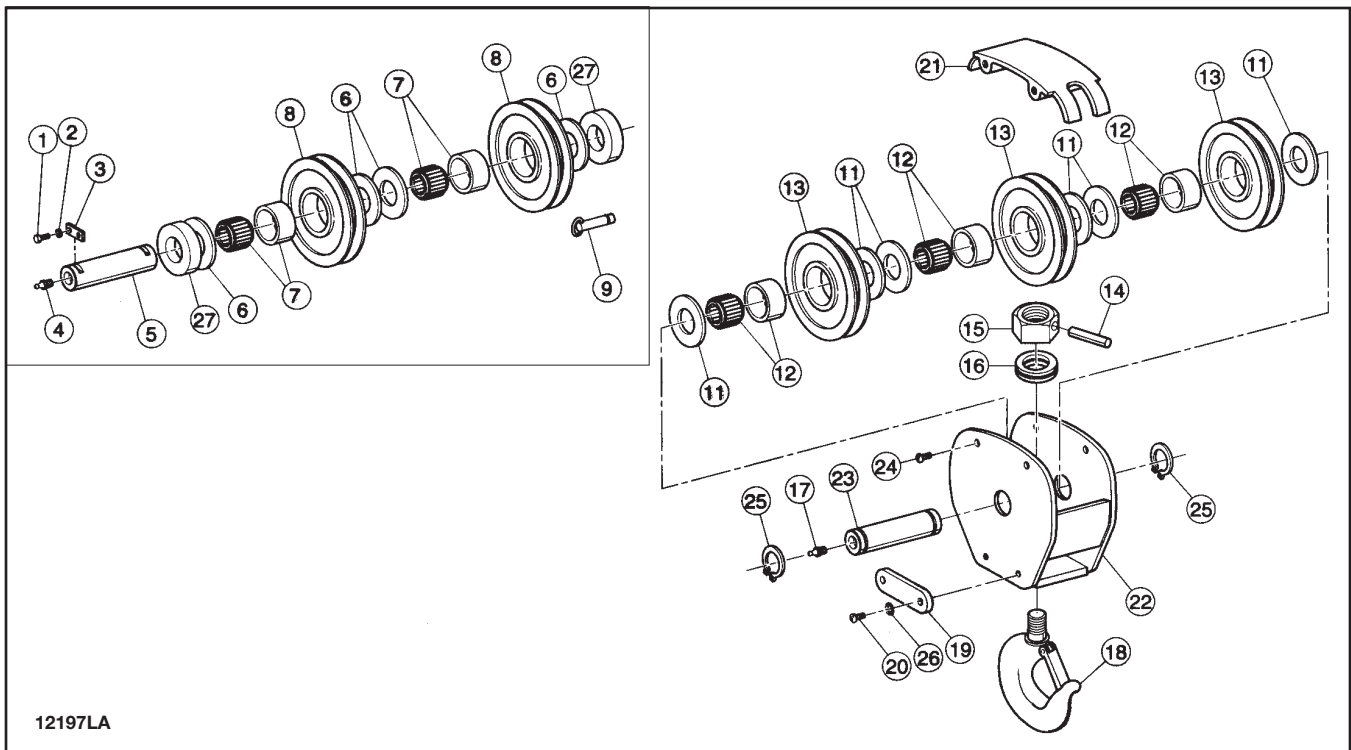

12197LA

Figure 9-11 . Upper and Lower Block Parts (3 & 5 Ton - Typical)

Ref. No.	Item Number	Part Name	QTY. Required	
			3-Ton/4 PS	5-Ton/6 PS
	800-1501	Block Assembly - Lower, 4 Part Single (Complete)	1	-
	800-1502	Block Assembly - Lower, 6 Part Single (Complete)	-	1
1	800-1503	Screw - Hex Head Cap	2	2
2	800-1504	Lockwasher	2	2
3	800-1505	Key Plate	1	1
4	800-1506	Fitting - Grease	1	1
5	800-1507	Pin - Upper Sheave	1	1
6	800-1508	Spacer Washer - Upper Sheave	2	4
7†	800-1509	Bearing - Upper Sheave (Includes Outer Race)	1	2
8†	800-1510	Sheave - Upper	1	2
9	800-1535	Pin - Rope Guide	2	2
11	800-1513	Spacer Washer - Lower Sheave	4	6
12†	800-1514	Bearing - Lower Sheave (Includes Outer Race)	2	3
13†	800-1515	Sheave - Lower	2	3
14	800-1516	Pin - Roll, Hook Nut	1	1

Ref. No.	Item Number	Part Name	QTY. Required	
			3-Ton/4 PS	5-Ton/6 PS
15	800-1517	Nut - Hook*	1	1
16†	800-1518	Bearing - Thrust, Hook	1	1
	800-1530	Shield - Bearing (Not Shown)	1	-
	800-1531	Washer - Thrust (Not Shown)	2	-
17	800-1519	Fitting - Grease	1	1
18†	800-1520	Hook Assembly - (includes Hook, Latch & Nut)	1	1
19	800-1521	Plate - Capacity	2	2
20	800-1522	Screw - Round Head, Self-Tapping (Capacity Plate)	4	4
21	800-1523	Guard - Sheave	1	1
22	800-1524	Body - Lower Block	1	1
23	800-1525	Pin - Lower Sheave	1	1
24	800-1526	Screw - Button Head Cap, Self-Locking (Sheave Guard)	4	4
25	800-1527	Ring - Retaining, External	2	2
26	800-1528	Lockwasher - (Capacity Plate)	4	4
27	800-1529	Spacer - Upper Block, 9/16"	2	-

† Recommended Spares

\* Hook Nuts with roll pins are not interchangeable - Available only as an assembly

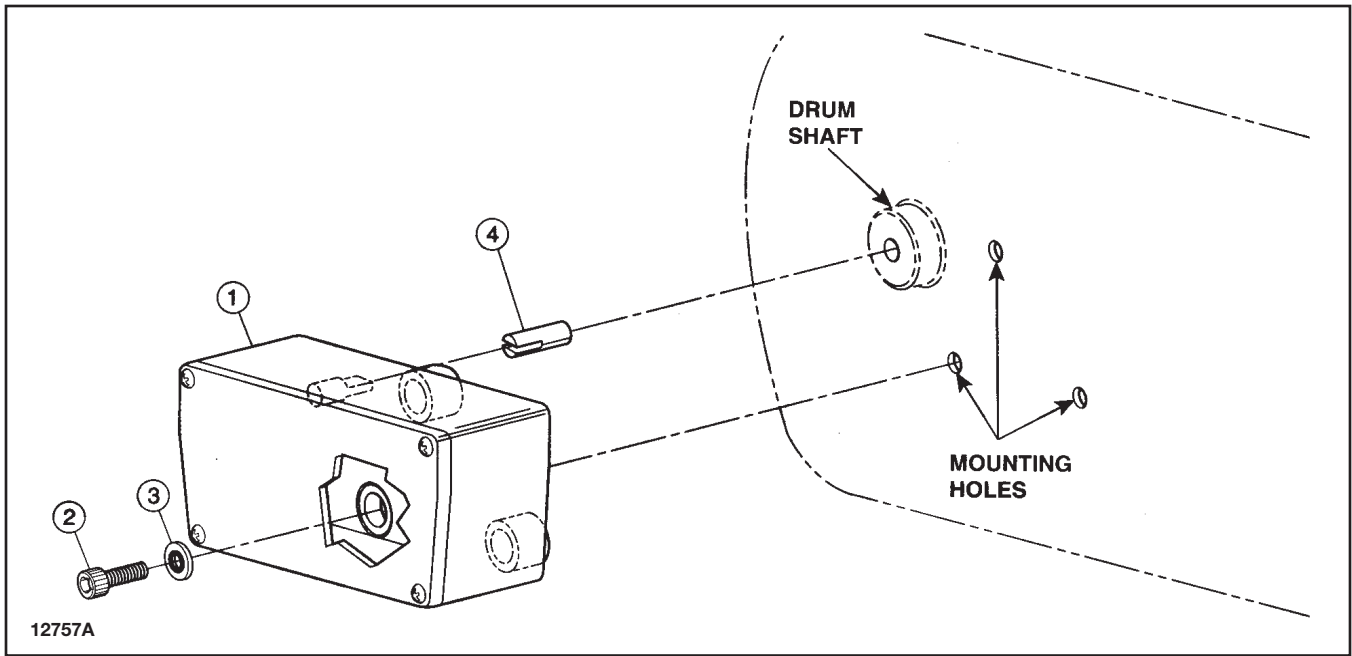

Figure 9-12. Screw-Type Limit Switch Parts

Ref. No.	Item Number	Part Name	Quantity Required
1	800-1655	Limit Switch Assembly (Includes Ref. Nos. 2, 3 and 4)	1
2	800-1651	Cap Screw - Hex Socket Head	3
3	800-1652	Sealing Washer	3
4	800-1657	Drum Shaft Insert	1

## **RECOMMENDED SPARE PARTS**

Certain parts of your hoist will, in time, require replacement under normal wear conditions. It is suggested that the following parts be purchased for your hoist as spares for future use.

**One friction disc kit**

**One motor brake solenoid coil**

**One set of contactors**

**One transformer**

**One wire rope assembly**

**One gearcase gasket**

**Note:** When ordering parts always furnish Hoist Serial Number, Catalog Number, Motor Horsepower, Voltage, Phase, Frequency and Rated Load of Hoist on which the parts are to be used.

### **PARTS AND SERVICES ARE AVAILABLE IN THE UNITED STATES AND IN CANADA**

Parts for your hoist or trolley are available from your local authorized repair station. For the name of the nearest parts or service center, visit our website [www.cmworks.com](http://www.cmworks.com) or call the Columbus McKinnon customer service department at (800) 888-0985.



# WARRANTY

## LIMITATION OF WARRANTIES, REMEDIES AND DAMAGES

**Note: When ordering parts, always furnish Rated Load, Voltage, Phase, Hertz and Serial Number of hoist on which the parts are to be used. For the location of the nearest Repair Station, see the list located on the inside front cover.**

THE WARRANTY STATED BELOW IS GIVEN IN PLACE OF ALL OTHER WARRANTIES, EXPRESS OR IMPLIED, OF MERCHANTABILITY, FITNESS FOR A PARTICULAR PURPOSE, OR OTHERWISE, NO PROMISE OR AFFIRMATION OF FACT MADE BY ANY AGENT OR REPRESENTATIVE OF SELLER SHALL CONSTITUTE A WARRANTY BY SELLER OR GIVE RISE TO ANY LIABILITY OR OBLIGATION.

Seller warrants that on the date of delivery to carrier the goods are free from defects in workmanship and materials.

### SELLER'S SOLE OBLIGATION IN THE EVENT OF BREACH OF

WARRANTY OR CONTRACT OR FOR NEGLIGENCE OR OTHERWISE WITH RESPECT TO GOODS SOLD SHALL BE EXCLUSIVELY LIMITED TO REPAIR OR REPLACEMENT, F.O.B. SELLER'S POINT OF SHIPMENT, OF ANY PARTS WHICH SELLER DETERMINES TO HAVE BEEN DEFECTIVE or if Seller determines that such repair or replacement is not feasible, to a refund of the purchase price upon return of the goods to Seller.

Any action against Seller for breach of warranty, negligence or otherwise, must be commenced within one year after such cause of action occurs.

NO CLAIM AGAINST SELLER FOR ANY DEFECT IN THE GOODS SHALL BE VALID OR ENFORCEABLE UNLESS BUYER'S WRITTEN NOTICE THEREOF IS RECEIVED BY SELLER WITHIN ONE YEAR FROM THE DATE OF SHIPMENT. Seller shall not be liable for any damage, injury or loss arising out of the use of the goods if, prior to such damage, injury or loss, such goods are (1) damaged or misused following Seller's delivery to carrier; (2) not maintained, inspected, or used in compliance with applicable law and Seller's written instructions and recommendations; or (3) installed, repaired, altered or modified without compliance with such law, instructions or recommendations.

UNDER NO CIRCUMSTANCES SHALL SELLER BE LIABLE FOR INCIDENTAL OR CONSEQUENTIAL DAMAGES AS THOSE TERMS ARE DEFINED IN SECTION 2-715 OF THE UNIFORM COMMERCIAL CODE.

### INDEMNIFICATION AND SAFE OPERATION

Buyer shall comply with and require its employees to comply with directions set forth in instructions and manuals furnished by Seller and shall use and require its employees to follow such instructions and manuals and to use reasonable care in the use and maintenance of the goods. Buyer shall not remove or permit anyone to remove any warning or instruction signs on the goods. In the event of personal injury or damage to property or business arising from the use of the goods, Buyer shall within 48 hours thereafter give Seller written notice of such injury or damage. Buyer shall cooperate with Seller in investigating any such injury or damage and in the defense of any claims arising therefrom.

If Buyer fails to comply with this section or if any injury or damage is caused, in whole or in part, by Buyer's failure to comply with applicable federal or state safety requirements, Buyer shall indemnify and hold Seller harmless against any claims, loss or expense for injury or damage arising from the use of the goods.

### CMCO Warranty (HOISTS)

A. Columbus McKinnon Corporation ("Seller") warrants to the original end user ("Buyer") that, for a period of one (1) year from the date of Seller's delivery of the goods (collectively, the "Goods") to the carrier, the Goods will be free from defects in workmanship and materials.

B. IN THE EVENT OF ANY BREACH OF SUCH WARRANTY, SELLER'S SOLE OBLIGATION SHALL BE EXCLUSIVELY LIMITED TO, AT THE OPTION OF SELLER, REPAIR OR REPLACEMENT, F.O.B. SELLER'S POINT OF SHIPMENT, OF ANY GOODS THAT SELLER DETERMINES TO HAVE BEEN DEFECTIVE OR, IF SELLER DETERMINES THAT SUCH REPAIR OR REPLACEMENT IS NOT FEASIBLE, TO A REFUND OF THE PURCHASE PRICE UPON RETURN OF THE GOODS TO SELLER. NO CLAIM AGAINST SELLER FOR ANY BREACH OF

(i) SUCH WARRANTY WITH RESPECT TO THE ELECTRICAL COMPONENTS OF ANY GOOD SHALL BE VALID OR ENFORCEABLE UNLESS BUYER'S WRITTEN NOTICE THEREOF IS RECEIVED BY SELLER WITHIN ONE (1) YEAR FROM THE DATE OF SELLER'S DELIVERY TO THE CARRIER AND (ii) SUCH WARRANTY WITH RESPECT TO THE MECHANICAL COMPONENTS OF ANY GOOD SHALL BE VALID OR ENFORCEABLE UNLESS BUYER'S WRITTEN NOTICE THEREOF IS RECEIVED BY SELLER WITHIN ONE (1) YEAR FROM THE DATE THE DATE ANY ALLEGED CLAIM ACCRUES. EXCEPT FOR THE WARRANTY SET FORTH ABOVE, SELLER MAKES NO OTHER WARRANTIES WITH RESPECT TO THE GOODS, WHETHER EXPRESSED OR IMPLIED, INCLUDING ANY WARRANTIES OF MERCHANTABILITY, FITNESS FOR A PARTICULAR PURPOSE, QUALITY AND/OR THOSE ARISING BY STATUTE OR OTHERWISE BY LAW OR FROM ANY COURSE OF DEALING OR USE OF TRADE, ALL OF WHICH ARE HEREBY EXPRESSLY DISCLAIMED.

C. IN NO EVENT SHALL SELLER BE LIABLE TO BUYER OR ANY THIRD PARTY WITH RESPECT TO ANY GOOD, WHETHER IN CONTRACT, TORT OR OTHER THEORY OF LAW, FOR LOSS OF PROFITS OR LOSS OF USE, OR FOR ANY INCIDENTAL, CONSEQUENTIAL, SPECIAL, DIRECT OR INDIRECT DAMAGES, HOWSOEVER CAUSED. SELLER'S MAXIMUM LIABILITY TO BUYER WITH RESPECT TO THE GOODS SHALL IN NO EVENT EXCEED THE PRICE PAID BY BUYER FOR THE GOODS THAT ARE THE SUBJECT OF THE APPLICABLE CLAIM.

D. Seller shall not be liable for any damage, injury or loss arising out of the use of the Goods if, prior to such damage, injury or loss, such Goods are: (1) damaged or misused following Seller's delivery to the carrier; (2) not maintained, inspected, or used in compliance with applicable law and Seller's written instructions and recommendations; or (3) installed, repaired, altered or modified without compliance with such laws, instructions or recommendations.

E. This warranty is limited and provided only to the original end user. Each Good must be registered within sixty (60) days of receipt of each product to establish eligibility. Please register at [www.cmworks.com/hoist-warranty-registration](http://www.cmworks.com/hoist-warranty-registration) or submit registration card via US mail.

F. Any action against Seller for breach of warranty, negligence or otherwise must be commenced by Buyer within one (1) year after: (a) the date any alleged claim accrues; or (b) the date of delivery of the Goods to Buyer, whichever is earlier.

## WARNING

Alterations or modifications of equipment and use of non-factory repair parts can lead to dangerous operation and injury.

### TO AVOID INJURY:

- Do not alter or modify equipment.
- Do use only factory replacement parts.



USA: Ph: (800) 888.0985 • (716) 689.5400 • Fax: (716) 689.5644 • [www.cmworks.com](http://www.cmworks.com)

CANADA: Ph: (877) 264.6478 • Fax: (877) 264.6477 • [www.cmworks.com](http://www.cmworks.com)