

OPERATION, SERVICE & PARTS MANUAL

WIRE ROPE HOISTS



GLOBAL KING™

ELECTRIC WIRE ROPE HOISTS

Before installing hoist, fill in the information below.
Refer to the Hoist and Motor data plates.

Model No. _____
Serial No. _____
Purchase Date _____
Voltage _____
Rated Load _____

RATED LOADS THRU 20 METRIC TONNE

Follow all instructions and warnings for inspecting, maintaining and operating this hoist.

The use of any hoist presents some risk of personal injury or property damage. That risk is greatly increased if proper instructions and warnings are not followed. Before using this hoist, each operator should become thoroughly familiar with all warnings, **instructions and recommendations in this manual. Retain this manual for future reference and use.**

Forward this manual to operator. Failure to operate equipment as directed in manual may cause injury.

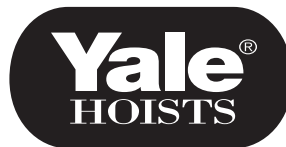

B, C & D-FRAME MODELS
(TOP RUNNING)

P/N: 11817502 REV. AB August 2017

FOREWORD

This manual contains important information to help you install, operate, maintain and service your new YALE electric hoist. We recommend that you study its contents thoroughly before putting the hoist into use. We also recommend that you read Section IX - Series Lifting Equipment of the European Federation of Materials Handling and Storage Equipment (FEM) and the applicable performance and safety standards referenced therein. Then, through proper installation, application of correct operating procedures, and by practicing the recommended maintenance procedures, you can expect maximum lifting service from the hoist.

It will likely be a long time before parts information found in the Parts List is needed. Therefore, after the hoist is installed and you have completely familiarized yourself with operation and preventative maintenance procedures, we suggest that this book be carefully filed for future reference.

When ordering replacement parts from this book, it will be necessary that you include with your order: the Hoist Serial Number and Model Number that are found on the nameplate attached to

the hoist as shown in Figure 4-1. For your convenience, a space has been provided on the front cover of this Manual for entering this information. We recommend that you fill it out immediately so it is readily at hand when needed.

The contents of this manual are of necessity, general in nature and may cover features not incorporated on your hoist; or, you may have ordered features not covered by this manual. Therefore, the user must exercise care in applying instructions given in this manual. If specific information not in this manual is required, contact the factory.

THE INFORMATION CONTAINED IN THIS MANUAL IS FOR INFORMATIONAL PURPOSES ONLY AND YALE DOES NOT WARRANT OR OTHERWISE GUARANTEE (IMPLIEDLY OR EXPRESSLY) ANYTHING OTHER THAN THE COMPONENTS THAT YALE MANUFACTURES AND ASSUMES NO LEGAL RESPONSIBILITY (INCLUDING, BUT NOT LIMITED TO CONSEQUENTIAL DAMAGES) FOR INFORMATION CONTAINED IN THIS MANUAL.

NOTICE: Information contained in this book is subject to change without notice.

INDEX

SECTION I GENERAL DESCRIPTION Page	
Paragraph 1-1 General.....	3
Paragraph 1-2 Basic Construction.....	3
Paragraph 1-3 Selection and Application Guide.....	3
SECTION II INSTALLATION	
Paragraph 2- 1 General.....	4
Paragraph 2-2 Bridge Requirements.....	4
Paragraph 2- 3 Lubrication	4
Paragraph 2- 4 Connecting Hoist to Electrical Service.....	4
Paragraph 2- 5 Pre-Operation Checks	5
SECTION III OPERATION	
Paragraph 3-1 General.....	6
Paragraph 3-2 Push Button Operation.....	6
Paragraph 3-3 Operating Precautions	6-7
SECTION IV LUBRICATION	
Paragraph 4-1 General.....	7
Paragraph 4-2 Changing Gear Case Oil.....	7
Paragraph 4-3 Lubrication of Hoist Cable	8
Paragraph 4-4 Lubrication of Limit Switch	8
Paragraph 4-5 Lubrication of Geared Trolley Wheels and Pinions	8
Paragraph 4-6 Lubrication of Rope Guide.....	8
Paragraph 4-7 Lubricant Specifications.....	9
SECTION V INSPECTION AND PREVENTIVE MAINTENANCE	
Paragraph 5-1 General	10
Paragraph 5-2 Inspection of Lower Block.....	13
Paragraph 5-3 Inspection of Upper Block	13
Paragraph 5-4 Inspection of Electrical Controls	13
Paragraph 5-5 Inspection of Rope Guide	13
Paragraph 5-6 Rope Inspection, Replacement & Maintenance.....	15
Paragraph 5-7 Rope Reeving.....	16
Paragraph 5-8 Inspection of Rope Drum & Shaft	17
Paragraph 5-9 Inspection of Hoist Gearing	17
Paragraph 5-10 Inspection of Motor Brake & Actuating Mechanism	21
Paragraph 5-11 Inspection of Traverse Drive.....	21
Paragraph 5-12 Testing Block Operated Limit Switch	22
Paragraph 5-13 Testing Over-Capacity Limit Switch	22
Paragraph 5-14 Testing Hoist	22
SECTION VI TROUBLESHOOTING CHART.....	23-24
SECTION VII ADJUSTMENTS	
Paragraph 7-1 Motor Brake Adjustment.....	25
Paragraph 7-2 Block Operated Limit Switch Adjustment	25
Paragraph 7-3 Geared Rotary Limit Switch Adjustment.....	25
Paragraph 7-4 Over-Capacity Limit Switch Adjustment	25
Paragraph 7-5 Shortening of Push Button Station	26
SECTION VIII WIRING DIAGRAMS	26-28
SECTION IX PARTS LIST	
Paragraph 9-1 General.....	29
Paragraph 9-2 List of Parts Illustrations.....	29

No part of this document may be reproduced in any form, in an electronic retrieval system or otherwise, without prior written permission of the publisher.

SECTION I - GENERAL DESCRIPTION

1-1. GENERAL

Yale “Global King” electric hoists are wire rope and drum type hoists that are manufactured with an integral trolley. These hoists are all low headroom models with the rope drum and upper block supported on opposite sides of the beam, by the trolley frame. There is one basic frame configuration for both the two and four part single reeved hoists. Both reeving configurations are referred to as “A” Frame hoists with the distinction made between reeving styles. The S4 designation refers to the 3.2 tonne (3200 kg) capacity with a four parts of rope single reeving configuration. The S2 designation refers to the 1.6 tonne (1600 kg) capacity with a two part of rope single reeving configuration. Both hoists feature an integral trolley that are offered with three different flange width ranges; 4-5/8” through 6”, 6-1/8” through 10” and 10-1/8” through 14” on a maximum flange thickness of 1-5/8”

Trolley is also available for operation on patented track beams using an optional wheel arrangement and special alignment bars.

The hoist motor is 2-speed with a 4:1 ratio between high and low speeds, as standard. The motor driven trolley has two available speeds with 1, 2 speed, or variable frequency control.

Throughout this manual, you will see references to the “S2” and “S4” Frame hoists. If you are unsure about which frame you have, count the number of rope falls that are supporting the lower block and/or see Section IV, Paragraph 4-2 for a simple gearcase measurement to determine the configuration of your hoist.

1-2. BASIC CONSTRUCTION.

Yale “Global King” hoists consist of a rugged steel frame which houses a lifting drum and serves as the suspension for carrying the entire hoist load. An aluminum gearcase, attached to one end of the drum frame, houses a triple-reduction, helical gear train. Applying power to the gearcase is a 2-speed, AC hoisting motor with a 4:1 speed ratio coupled with a 200% torque DC brake. High strength wire rope and a covered lower sheave block act as the load carrying means. Standard equipment includes a rope guide, a rotary-gear limit switch to limit hook travel in both up and down directions and an overload capacity limit switch. A block operated limit switch can be used to limit the upward travel of the lower block. An integral trolley, consisting of a 2-speed AC motor and a sealed worm reducer, applies torque to the trolley wheels through a cross shaft and pinion arrangement, which provides traverse motion to the hoist. A single NEMA 4/12 control enclosure houses both the hoist and trolley electrical system controls. A push button control station (purchased separately) for operating the hoist is suspended on a wire strain cable attached to the hoist.

1-3. SELECTION & APPLICATION GUIDE.

Hoist Duty Classification

Your YALE “Global King” hoist was designed to meet a specific duty classification as described by the FEM “Rules for the Design of Serial Lifting Equipment”. The methodology used to determine the duty class requirements of your specific application is shown below.

YALE “Global King” hoists are defined as “mechanisms” by the FEM and are classified as such by the following factors: **Class of Operating Time** and **Load Spectrum**. Your application must be definable by these two factors in order to determine duty classification.

Class of Operating Time

Class of Operating Time indicates the average period per day during which the mechanism is in operation, which is anytime the equipment is in motion. The Class of Operating Time is determined by calculation of the average daily operating time (average daily use):

Where:

- t = Average Daily Operating Time (hr/day)
- H = Average Hoist Height (ft)
- N = Number of Cycles Per Hour (cycles/hr)
- T = Daily Working Time (hr/day)
- V = Hoisting Speed (ft/min)

$$t = \frac{2 \times H \times N \times T}{V \times 60}$$

Load Spectrum

Load Spectrum indicates the extent of which the mechanism is subjected to maximum stresses (full capacity lifts) or whether it is subject to smaller loads only. Use the charts below to estimate your load spectrum. For an exact means of calculating your load spectrum, refer to FEM 9.511 “Classification of Mechanisms”.

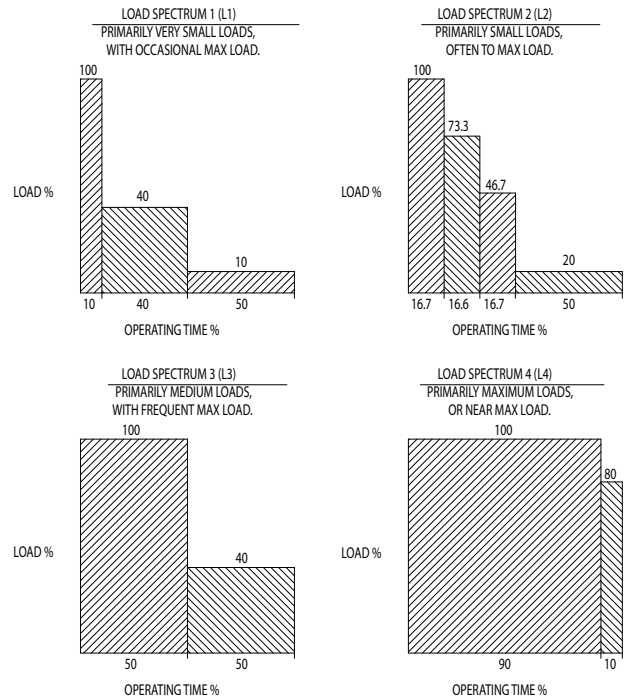

Once the average daily operating time, “t”, is calculated for a specific application, the Class of Operating Time can be identified. Using the Class of Operating Time along with the Load Spectrum, one can determine the duty classification requirement of the application. Defining the proposed equipment usage in this manner is critical to selecting the correct hoist for the application.

Classification of Mechanisms

Load Spectrum	Class of Operating Time				
	T2	T3	T4	T5	T6
	Average Daily Operating Time (hr/day)				
	¼ – ½	½ – 1	1 – 2	2 – 4	4 – 8
L1	1Dm	1Cm	1Bm	1Am	2m
L2	1Cm	1Bm	1Am	2m	3m
L3	1Bm	1Am	2m	3m	4m
L4	1Am	2m	3m	4m	5m

Example:

An application requires that a hoist be used to repeatedly lift and move small to medium size loads, but occasionally will be required to lift heavy loads equal to 3.2 metric tonne. This hoist will be operated daily for a single 8-hour shift and will be required to perform 15 lifting cycles per hour. The average height, which the load is lifted, is 18 ft. at a desired speed of 20ft/min.

The average daily operating time can be calculated from the above information:

$$t = \frac{2 \times 18 \times 15 \times 8}{20 \times 60} = 3.6 \text{ hr/day}$$

The description of the example application implies that the load spectrum is likely an L1 or L2. Choosing an L2 load spectrum factor and using the calculated average daily operating time, one can determine from the "Classification of Mechanisms" table above, the duty classification for this application is 2m for a 5 metric ton rated hoist.

For a more thorough explanation of the determination of mechanism classification, refer to FEM 9.511 "Classification of Mechanisms".

Your Yale "Global King" hoist was designed to meet the duty classifications as described above. The standard 5t, 10t, 15t and 20t capacity models are rated at 2m duty classification, while the 7.5t capacity model is rated at 3m duty classification.

SECTION II - INSTALLATION

2-1. GENERAL

Yale "Global King" electric hoists are lubricated and tested before being shipped from the factory. To place a hoist in service, connect to electrical service (Paragraph 2-4) and perform pre-operation tests and checks (Paragraph 2-5).

 WARNING
Working in or near exposed energized electrical equipment presents the danger of electric shock.
TO AVOID INJURY: DISCONNECT POWER AND IMPLEMENT LOCKOUT/TAGOUT PROCEDURE BEFORE REMOVING COVER OR SERVICING THIS EQUIPMENT.

2-2. BRIDGE REQUIREMENTS.

The successful operation of a double girder trolley depends upon a properly installed bridge. The bridge should be for adequacy of the following:

- a. Trolley rail must be sized properly. Acceptable rail sizes are 25# - 80# A.S.C.E. rail depending on the hoist model and capacity.
- b. Trolley rails are to be securely fastened to the supporting girder.
- c. The rails shall be straight, parallel, level and at the same elevation. The distance (gauge) center-to-center of bridge rails, as well as, the rail elevation shall be within a tolerance of plus or minus 1/8".

- d. Rail joints must be smooth and held in tight alignment by properly fitted rail joint bars so that the ends are held tightly with no cracks or openings.
- e. The bridge should be designed in accordance with specifications outlined by the Crane Manufacturers Association of America for the maximum wheel loads involved. loads involved.
- f. Size and placement of trolley bumper stops should be checked to insure that they are of the proper height and width to fully contact the trolley bumpers and also placed so as to stop the trolley with sufficient clearance between any portion of the trolley and the surrounding structures.

 WARNING
Failure to use proper end stops on the crane bridge may result in serious injury, death and /or damage to equipment and property.
TO AVOID INJURY: Once the trolley has been installed on the rails, end stops suitable for the application must be installed at both ends of each rail to prevent the trolley from running off the ends of the rails.

2-3. LUBRICATION.

All Yale trolleys are completely lubricated at the factory. It is important that all components requiring lubrication be checked. Complete instructions concerning initial lubrication are to be found in SECTION IV. Refer to the manufacturer's manuals on purchased equipment (those components not built by Yale® Shaw-Box®). The manufacturer's lubrication instructions supersede instructions given in this manual for similar equipment.

2-4. CONNECTING HOIST TO ELECTRICAL SERVICE.

Electrical service to the hoist may be power cable or a guarded system having sliding shoe or wheel type collectors.

Follow ANSI/NFPA 70, state, and local electrical codes including the grounding provisions thereof when providing electrical service to the hoist.

Make electrical connections using the appropriate wiring diagrams furnished with the hoist. All electrical connections, including connections to collectors or power cord, shall be made only by qualified journeyman electricians.

NOTICE
Be certain that electrical power supply is OFF and locked in the open position before attempting any electrical connections to the hoist. This equipment must be effectively grounded according to the National Electric Code ANSI/NFPA 70, or other applicable codes.

CAUTION

Power supply to hoist and trolley must be the same voltage, frequency, and phase that are specified on the hoist and trolley nameplate.

2-5. PRE-OPERATIONAL CHECKS

- a. Check Oil Level. (Figure 4-1) The gearcase has been filled with oil to the proper level. However, this should be re-checked before operating the hoist.

Check oil level by removing the plug indicated in Figure 4-1. When properly filled, oil should be level with the bottom of the tapped hole. Fill to this level with oil as specified in Paragraph 4-2.e.

- b. Check trolley wheel engagement to the rail for float clearance. Make visual checks as well as measurement checks.
- c. Check all connections for tightness of bolts, inclusion of lock washers or other type fasteners to ensure correct components have been used. This check must be made for all connections: mechanical, structural and electrical, including both field and factory-made connections.
- d. Check to ensure that all shipping supports, tie-downs, brackets or other items used only for shipping or storage purposes are removed from the equipment.
- e. Check to be certain that the trolley and bridge is clear and free of all obstructions.
- f. Check Push Button Operation and Phasing.

To properly check the phase of the hoist, follow these steps:

1. With "POWER OFF", operate all the push buttons and determine that they do not bind or stick in any position.

WARNING

If any push button binds or sticks in any position - DO NOT TURN POWER ON - determine the cause and correct the malfunction before operating.

2. Connect hoist to power source.
3. Operate "UP" button briefly to determine direction of hook travel.
4. If hook raises when "UP" button is depressed, phasing is correct.
5. If hook lowers when "UP" button is depressed, hoist is "Reverse Phased." TURN AND LOCK POWER OFF and check the pushbutton wiring. If the pushbutton was wired properly, correct the problem by interchanging any two leads at power source connection. Do not change internal wiring of hoist.

WARNING

On three phase hoists, it is possible to have "Reverse Phasing" causing the block to lower when the "UP" button is depressed. When this condition exists, the automatic limit switch is inoperative and hoist operation will be dangerous.

- g. Check Lower Block and Hoisting Cable. Depress "DN" push button and run lower block to its lowest position. No less than two wraps shall remain on the drum with the loaded hook in its lowest position. Also check to see that the lower block and rope do not twist excessively. If it does twist to the extent that two ropes rub against each other, disengage the swaged rope end from the frame anchor and twist the rope four or five turns in a direction opposite to that which the block turns. Reconnect rope to the frame anchor, holding firmly to eliminate rope twisting back to its original position. Operate hoist up and down a few times. If lower block still rotates excessively, repeat process until twisting is corrected.
- h. Lubricate Hoisting Cable. For longer cable life, it is recommended that the cable be lubricated at time of installation by applying a heavy coating of lubricant CL (Para. 4-7) as outlined in SECTION IV, Paragraph 4-3.
- i. Check Limit Switch Operation.
1. A geared rotary type upper and lower limit switch is provided as standard equipment on Yale "Global King" hoists. This switch is adjustable and although preset by the factory, it should be adjusted at time of installation to the desired high and low limits of lower block travel. Refer to SECTION VII, Paragraph 7-3.
 2. A block operated upper limit switch is furnished on Yale "Global King" hoists. This limit stop is factory set to stop the lower block at the safest high position, guarding against over travel and possible damage to hoist. Minimal adjustments can be made. When equipped with this option, the hoist should be tested by jogging the lower block against the limit switch actuator arm to assure the switch is functioning properly. When the lower block lifts the actuator, the hoist will automatically stop. If the lower block coasts through the limit switch when lifting, a reverse switch will automatically close and reverse direction of motion to lowering.
- j. An over-capacity limit switch is provided as standard equipment on Yale "Global King" hoists. This switch is adjustable and although preset by the factory, it should be adjusted at the time of installation to the desired setting. Refer to SECTION VII, Paragraph 7-4.
- k. When first using the hoist and trolley, operate with lighter loads through full travel before applying maximum load.

WARNING

Damage to the hoist, a dropped load, and injury may result if limit switches fail due to improper use.

TO AVOID INJURY:

UNDER NORMAL OPERATING CONDITIONS, STOP HOIST TRAVEL BEFORE ENGAGING LIMIT SWITCHES. LIMIT SWITCHES ARE SAFETY DEVICES AND SHOULD NOT BE USED AS NORMAL OPERATING CONTROL.

WARNING

Some hoists may be shipped with the electrical controls loose (disconnected) and will not have the upper and lower limit switches connected. **DO NOT OPERATE HOIST UNTIL LIMIT SWITCHES ARE PROPERLY CONNECTED AND ADJUSTED.** Failure to do so may allow hoist to be operated beyond proper travel limits, which can cause load to drop, resulting in damage to equipment or injury.

SECTION III - OPERATION

3-1. GENERAL

Operation of YALE "Global King" hoists is controlled by a convenient pendant push button station. With it, the hoist can be controlled to give fast lifting and lowering; or controlled to lift or lower the load in small increments, providing accurate positioning capability. The push button station has a built-in interlock to prevent depressing opposing buttons simultaneously.

When first using the hoist, break in by operating under lighter loads to full travel before applying maximum load.

3-2. PUSH BUTTON OPERATION

- a.) For the hoist motion depress push button marked "UP" to raise load.
- b.) For the hoist motion depress push button marked "DN" to lower load.
- c.) For the trolley traverse motion:
With two speed control depress buttons marked "<<" , ">>" or "N", "S" to activate the trolley traverse motion

With one speed control depress buttons marked "<" , ">" or "N", "S" to activate the trolley traverse motion.
- d.) On two-speed hoist or trolley motions, partial depression of a button operates hoist or trolley at slow speed; depressing button completely operates hoist or trolley at full speed.

CAUTION

Excessive "jogging" will cause premature burning of contact tips, motor overheating and premature brake wear.

3-3. OPERATING PRECAUTIONS

Safe operation of an overhead hoist is the operator's responsibility. Listed below are some basic rules that can make an operator aware of dangerous practices to avoid and precautions to take for his own safety and the safety of others. Observance of these rules, in addition to frequent examinations and periodic inspection of the equipment, may prevent injury to personnel and damage to equipment.

WARNING

Equipment covered herein is not designed or suitable as a power source for lifting or lowering persons.

- a) **DO** read applicable sections of FEM Section IX, Series Lifting Equipment and the Operation, Service and Parts Manual.
- b) **DO** be familiar with hoist operating controls, procedures, and warnings.
- c) **DO** make sure hook travel is in the same direction as shown on the controls. If opposite direction occurs, see Pre-Operation Checks, Section II, Paragraph 2-4.b.
- d) **DO** make sure hoist limit switches function properly.
- e) **DO** maintain firm footing when operating hoist.
- f) **DO** make sure that the load slings or other approved attachments are properly sized and seated in the hook saddle.
- g) **DO** make sure that the hook latch is closed and not supporting the load.
- h) **DO** make sure that load is free to move and will clear all obstructions.
 - i) **DO** take up slack carefully, check load balance, lift a few inches and check load's holding action before continuing.
 - j) **DO** avoid swinging of load or load hook.
 - k) **DO** make sure that all persons stay clear of the suspended load.
 - l) **DO** warn personnel of an approaching load.
- m) **DO** protect wire rope from weld splatter or other damaging contaminants.
- n) **DO** promptly report any malfunction, unusual performance, or damage of the hoist.
- o) **DO** inspect hoist regularly, replace damaged or worn parts, and keep appropriate records of maintenance.
- p) **DO** use the hoist manufacturer's recommended parts when repairing a hoist.
- q) **DO** use hook latches.
- r) **DO** apply lubricant to the wire rope as recommended.
- s) **DO NOT** lift more than rated load.
- t) **DO NOT** use the hoist load-limiting device to measure the load.
- u) **DO NOT** use damaged hoist or hoist that is not working properly.
- v) **DO NOT** use the hoist with twisted, kinked, damaged, or worn wire rope.
- w) **DO NOT** lift a load unless wire rope is properly seated in its groove(s).
- x) **DO NOT** use wire rope as a sling or wrap rope around the load.
- y) **DO NOT** lift a load if any binding prevents equal loading on all

supporting ropes.

- z) **DO NOT** apply the load to the tip of the hook.
- aa) **DO NOT** operate unless load is centered under hoist.
- bb) **DO NOT** allow your attention to be diverted from operating the hoist.
- cc) **DO NOT** operate the hoist beyond limits of wire rope travel.
- dd) **DO NOT** use limit switches as routine operating stops unless recommended. They are emergency devices only.
- ee) **DO NOT** use hoist to lift, support, or transport people.
- ff) **DO NOT** lift loads over people.
- gg) **DO NOT** leave a suspended load unattended unless specific precautions have been taken.
- hh) **DO NOT** allow sharp contact between two hoists or between hoist and obstructions.
 - ii) **DO NOT** allow the rope or hook to be used as a ground for welding.
 - jj) **DO NOT** allow the rope or hook to be touched by a live welding electrode.
- kk) **DO NOT** remove or obscure the warnings on the hoist.
 - ll) **DO NOT** adjust or repair a hoist unless qualified to perform hoist maintenance.
- mm) **DO NOT** attempt to lengthen the wire rope or repair damaged wire rope.
- nn) **DO NOT** allow personnel not physically fit or properly qualified, to operate hoist.
- oo) **DO NOT** operate hoists unless hook moves in the same direction as indicated on the push button. If opposite direction occurs, see pre-operation checks, Section II Paragraph 2-4.b.
- pp) **DO NOT** operate hoist unless limit switches are operating properly.
- qq) **DO** avoid operating hoist when hook is not centered under hoist. Avoid side pulls and swinging of load or load hook when traveling hoist.
- rr) **DO** operate hoist within recommended duty cycle and **DO NOT** “jog” unnecessarily.
- ss) **DO** conduct regular visual inspections for signs of damage and wear.
- tt) **DO NOT** operate hoist with hooks that have opened up. See Section V, Paragraph 5-2.f.
- uu) **DO** provide supporting structure that has an appropriate design factor based on the load rating and dead weight of the hoist. If in doubt of the supporting structure’s strength, consult a structural engineer.
- vv) **DO NOT** use hoist in location that will not allow operator movement to be free of the load.
- ww) **DO**, when starting to lift, move the load a few inches at which

time the hoist should be checked for proper load holding action. The operation shall be continued only after the operator is assured that the hoist is operating properly and that the load is supported in the center of the base/bowl/saddle of the hook.

- xx) **DO** observe recommended inspection and maintenance procedures.
- yy) **DO** use common sense and best judgment whenever operating a hoist.
- zz) **DO NOT** lift guided loads.

SECTION IV - LUBRICATION

4-1. GENERAL

The lubrication services outlined in Paragraphs 4-3 thru 4-6 should be performed before initial operation of the hoist. The lubrication services outlined in Paragraphs 4-2 thru 4-6 should be performed at regular intervals at least every six (6) months, coinciding with spring and fall seasons is recommended. The reason for this is that on hoists installed outside or in unheated areas a “cold test” oil is required in such (below freezing) climates making seasonal changes necessary.

4-2. CHANGING GEARCASE OIL

Figure 4-1. View of Hoist Showing Location of Name Plates

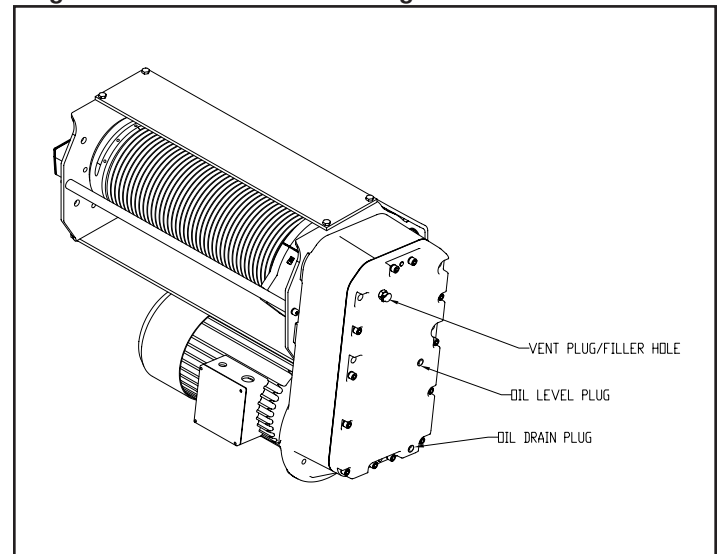

and Oil Plugs (“B” & “C” Frame Shown)

- a) Add 5% solution of Mobilsol A (or equivalent) to the oil and run for a short time. This will clean components and hold particles in suspension for draining.
- b) Remove oil drain plug from bottom of gearcase and drain oil out. Dispose of oil in accordance with local environmental codes.

⚠ WARNING

DO NOT operate hoist with the hoisting rope out of the drum grooves. Such operation may result in damage to the rope guide and rope and could result in the rope breaking. This may result in dropping the load that can cause damage to equipment and injury to operator or other personnel. Hoist rope will remain in the drum grooves during operation under normal operating conditions, however, slack or kinked rope, excessive side pulls, swinging or jerking of load, or similar abuse, may cause damage to the rope guide causing the rope to leave the grooves.

⚠ CAUTION

Avoid skin contact with Mobilsol A. In case of skin contact: dry wipe the skin, cleanse the area with a waterless hand cleaner and follow by washing thoroughly with soap and water.

4.7 LUBRICANT SPECIFICATIONS		AMBIENT TEMPERATURE		
		-20° to +50° F (-29 to +10°C)	50° to 125° F (10° to 52°C)	125° to 250°F (52° to 121°C)
GCOH	AGMA Lubricant	No. 6	No. 7 EP	No. 7
Gear Case Oil Hoise Gearcase	Viscosity @ 100° F	1335-1632 SUS	1919-2346 SUS	1919-2346 SUS
	Viscosity Index	154	95	158
	Pour Point	-40° F	20°F	-37°F
	Mobil® Oil Corp	Mobil® SHC 632	Mobilgear® 600, XP-460	Mobil® SHC 634
	Shell® Oil Corp	Omala® RL 320	Omala® 460	Omala® RL 460
	Texaco® Inc.	Pinnacle® 320	Meropa® 460	Pinnacle® 460
SG	NLGI Grease	No.1		
Spline Grease	ASTM D217 Worked Penetration	310-340		
	Dropping Point	320°F (160°C)		
	Base	Lithium		
	Mobile® Oil Corp.	----- Mobilux® EP 111 -----		
WG	Viscosity @ 100° F	25,000 SUS (contains diluent)		
Wheel Gear and Pinion Grease	Mobil® Oil Corp.	----- Molitac® 375 NC -----		
	Texaco® Inc.	----- Crater H® -----		
CL	No Specification			
Cable Lubricant Wire Rope Lubricant	Amoco® Oil Co.	----- Amovis® 5-X -----		
	Mobil® Oil Corp.	----- Mobilarma® 798 -----		
	Sun® Oil Corp.	----- Sunoco® Wire Robe Lubricant -----		
	Texaco® Inc.	Crater A	Texclad® 2	
GO	AGMA Lubricant	No. 1	No. 2	
General Oil General Oiling to Prevent Rusting or Provide Limited Lubrication for Points Not Considered Normal Wear Points	Viscosity @ 100° F	193-235 SUS	284-347 SUS	
	Viscosity Index	60 Min.	60 Min.	
	Pour Point	-20°F (-29°C)	10°F (-12°C)	
	Amoco® Oil Co.	Rykon® Oil 46	American Industrial Oil® 68	
	Mobil® Oil Corp.	----- Mobil® DTE Oil Heavy-----		
	Shell® Oil Co.	Rotella® 10W	Rotella® 10W-30	
	Sun® Oil Co.	Sunvis® 932	Sunvis® 968	
	Texaco® Oil Inc.	Rando® Oil 46	Rando® Oil 68	
MPG	NLGI Grease	No.1	No. 2	
Multipurpose Grease Grease Lubricated Wear Points Provided	6ASTM Worked Penetration	310-340	265-295	
	Dropping Point	360°F (182°C)	360°F (182°C)	
	Base	Lithium	Lithium	
	Amoco® Oil Co.	Amolith® Grease 1 EP	Amolith® Grease No. 2 EP	
	Mobil® Oil Corp.	Mobilith® AW1	Mobilith® AW 2	
	Shell® Oil Co.	----- Retinax LC-----		
	Sun® Oil Co.	Presitge® 741 EP	Sunoco® Multipurpose 2	
	Texaco Oil Inc.	Multifak® EP 1	Multifak® EP 2	
GCOT	AGMA Lubricant	No. 7 or 7C (Compounded)	No. 8 or 8C Compounded	Refer to YALE Hoist Field Service Department for Gearcase Operating Temperatures above 125° F
Gear Case Oil	ISO Viscosity Grade	460	680	
	Amoco® Oil Corp.	Worm Gear Oil	Cylinder #680	
Traverse Gear Case	Mobil® Oil Corp.	Mobil® SHC 643 Synthetic, Mobil® 600W	Mobil® SHC 634 Sythetic, Extra Hecla Super	
	Shell® Oil Co.	Valvata® J460	Valvata® J680	
	Texaco Oil Inc.	Meropa® 460	Meropa® 680	

SECTION V - INSPECTION AND PREVENTIVE MAINTENANCE

5-1. GENERAL

All YALE “Global King” hoists are inspected and tested at the factory. Regular in-service inspection and preventative maintenance programs not only help reduce overall maintenance costs but may also prevent service shutdowns by forewarning of problems that could cause these shutdowns. Regular inspections, periodic minor adjustments, regular cleaning and lubrication and replacement of worn parts can help preserve good performance and operation of your hoist.

Many factors influence the inspection and preventative maintenance program required for your hoist. Frequency and severity of service and material handled, local environmental conditions and various applicable codes are some of the factors that the user must consider to adjust inspection and maintenance program outlined in this section to meet his specific conditions.

The inspection and maintenance intervals outlined in this section are considered a minimum. Recommended in the schedule are minimum inspection and maintenance intervals based on average daily use in a normal environment. Your YALE “Global King” hoist was designed to meet a specific duty classification as described by the FEM “Rules for the Design of Serial Lifting Equipment” and is to be used in accordance with the duty rating identified on the equipment nameplate. For more details regarding hoist duty cycles and average daily use, please reference FEM Section IX, Series Lifting Equipment or the Hoist Duty Classification page in this manual.

Environmental conditions in which the hoist operates are also important considerations for the user, when adjusting hoist inspection and maintenance programs to local conditions. Frequency of inspection and maintenance must be increased if hoist is subjected to severe atmospheric environmental conditions, such as corrosive vapors, extreme heat or cold, cement or dust and other airborne contaminants. The user should carefully consider all environmental conditions and adjust frequency and degree of maintenance for his local conditions. Consult the factory’s Field Service Department for advice regarding unusual environmental conditions.

Various codes also regulate inspection and maintenance programs. Attention must be given to applicable federal standards, OSHA regulations, national standards, state and local codes which may include mandatory rules relating to hoist inspection and maintenance. The user should become familiar with all applicable codes for his area and be guided accordingly.

Listed on the Recommended Inspection and Maintenance Schedule are inspection frequencies and requirements. Perform these inspections regularly as scheduled and additional inspections as may be required for activity, service, and environment of your hoist. The hoist operator must be responsible for determining the operating conditions and severity of service.

Inspection Schedule and Maintenance Report Form.

Shown on page 12 of this manual is a recommended Inspection Schedule and Maintenance Report form that lists various components of the hoist. The form also includes trolley components, runway components, and miscellaneous items. This form is suggested as a guide for written inspection reports. Inspections are recommended each month and should be performed thoroughly enough to inform the hoist user of deficiencies for any item listed. This form does not supersede the Inspection and Maintenance Schedule listed on page 11

of this manual but may be used to record scheduled inspection and maintenance services required.

The user should revise the inspection interval, add additional units or provide a similar form to suit particular conditions that may exist. However, written, dated and signed inspection reports should be maintained particularly on critical items such as hoist hooks, hoisting rope, sheaves, drums and brakes. Periodic review of old inspection reports can point out service life of hoist components, forecasting need for adjustment, repair or replacement of these components.

As a matter of expedience, appointed maintenance personnel inspecting hoist can also take care of minor adjustments, repairs and cleaning, where required. Note column on Inspection Schedule and Maintenance Report form headed Corrective Action and Notes. When corrective action is made during inspection, note condition of part or unit as inspected in appropriate Condition column with a check mark (Ö). Note “during inspection” corrective action taken and date in space provided. In this manner, items requiring further attention will be checked (Ö) without showing corrective action. This will advise the person responsible for hoist operation and safety, or whoever reviews the inspection reports, that deficiencies exist. The designated person will check all deficiencies as listed and re-examine or otherwise determine whether they constitute a safety hazard.

WARNING

Deficiencies may be hazardous to personnel and equipment. Do not operate a hoist having deficiencies unless a designated qualified person has determined that these deficiencies DO NOT constitute a safety hazard.

Written, dated and signed inspection reports for many items are mandatory under OSHA regulations, and many state safety codes.

It is strongly recommended that the Inspection Schedule and Maintenance Report, shown herein, be completed by a qualified person designated with the responsibility for hoist operation and safety or an inspector appointed by this person.

Inspection records can point out the service life of hoist components and help forecast the need for adjustments, repairs, and ordering of replacement parts. File and review these reports after each inspection.

All YALE “Global King” hoists are equipped with a Pulse™ monitor, which is wired into the control circuit in the control enclosure. This equipment consists of a circuit board, a serial communications port, and onboard memory, which will retain data even when the hoist is removed from power. The Pulse monitor takes the “pulse” of the equipment by recording the most recent hoist activities including all normal operation events, motor starts, overcapacity lifts and thermal overload events. In addition, the monitor records the total cumulative operating time and motor starts for the life of the equipment. Each Pulse monitor is programmed with the equipment serial number at the factory.

Data may be downloaded from the monitor, via the serial communications link, by a certified technician. Pulse monitor data may be used to determine equipment usage and to verify that the application does not exceed the hoist duty rating as identified on the equipment nameplate. The data can also be helpful in establishing and scheduling preventative maintenance as well as an aid in troubleshooting the equipment. For additional information refer to the Pulse monitor manual (P/N 11817503) sent with this manual.

INSPECTION SCHEDULE AND MAINTENANCE REPORT

HOIST SERIAL NO. (MFGRS) _____

CUSTOMER CRANE IDENTITY NO. _____

RATED LOAD _____

LOCATION IN PLANT _____

TYPE _____

THIS INSPECTION IS MONTHLY ANNUAL

VOLTAGE _____

SEMI-ANNUAL

INSPECTED BY: _____ **DATE** _____

Component, Unit Or Part and Location		* Recommended Inspection Interval			CONDITION (Check column best indicating condition when part or unit is inspected. Use note column to the right if condition is not listed below.)						Corrective Action Notes
		MONTHLY	SEMI-ANNUAL	ANNUAL	GOOD	ADJUSTMENT REQUIRED	REPAIR REQUIRED (Loose Parts or Wires)	REPLACEMENT REQUIRED (Worn or Damaged)	LUBRICATION REQUIRED (Low Oil or Grease, Rust or Corrosion)	CLEANING OR PAINTING REQUIRED	
HOIST	Motor	<input type="radio"/>									(Indicate corrective action taken during inspection and note date. For corrective action to be done after inspection, a designated person must determine that the existing deficiency does not constitute a safety hazard before allowing unit to operate. When corrective action is completed, describe and note date in this column.) DATE
	Motor Brake	<input type="radio"/>									
	Mechanical Load Brake	<input type="radio"/>									
	Overload Clutch	<input type="radio"/>									
	Couplings	<input type="radio"/>									
	Gears, Shafts, & Bearings	<input type="radio"/>									
	Upper Block	<input type="radio"/>									
	Lower Block	<input type="radio"/>									
	Hook & Throat Opening	<input checked="" type="radio"/>		X						Record Hook Throat Opening	
	Hoist Rope	<input checked="" type="radio"/>									
	Rope Drum		<input type="radio"/>								
	Rope Guide		<input type="radio"/>								
	Guards		<input type="radio"/>								
Limit Switch	<input type="radio"/>										
CONTROL STATION OR PUSH BUTTON	Pushbutton		<input type="radio"/>								
	Wiring		<input type="radio"/>								
TROLLEY	Motor	<input type="radio"/>									
	Brake (when so equipped)	<input type="radio"/>									
	Couplings	<input type="radio"/>									
	Gears, Shafts, & Bearings	<input type="radio"/>									
	Frame			<input type="radio"/>							
	Wheels		<input type="radio"/>								
	Bumpers		<input type="radio"/>								
	Guards		<input type="radio"/>								
	Conductors	<input type="radio"/>									
	Collectors	<input type="radio"/>									
RESISTORS	Hoist		<input type="radio"/>								
	Trolley		<input type="radio"/>								
RUNWAYS	Monorail Joints		<input type="radio"/>								
	Monorail		<input type="radio"/>								
	Main Conductors	<input type="radio"/>									
	Main Collectors	<input type="radio"/>									
MISC.	General Condition		<input type="radio"/>								
	Load Attachment Chains	<input checked="" type="radio"/>									
	Rope Slings & Connections	<input checked="" type="radio"/>									
	Change Gearcase Lub.			<input type="radio"/>							
	Grounding Faults		<input type="radio"/>								

*See text for DAILY & WEEKLY REQUIREMENTS. ● SIGNED & DATED REPORT REQUIRED – OSHA.
 INSPECTION INTERVAL X MAGNETIC PARTICLE OR EQUIVALENT EXAMINATION REQUIRED.

Typical Inspection Schedule and Maintenance Report form.
 User must adjust inspection interval and components to suit his individual conditions and usage.

⚠ WARNING

Do not operate a hoist having unusual vibrations, sounds, or with anything visibly or otherwise wrong. Danger may be present that the hoist operator cannot see. Determine and correct the cause of unusual conditions and make certain hoist can be operated safely.

5-2. INSPECTION OF LOWER BLOCK

Refer to the Section IX, Figure 9-4.
Lower Block Assembly.

- Check lubrication of all parts. Also lubricate the shank of the hook that passes through the crosshead. If the thrust bearing is removed, apply MPG grease (Section IV, Paragraph 4-7).
- Check each sheave to insure rope groove is smooth and free from burrs, or other surface defects.
- Check each sheave for freedom of rotation; replace bearings if defective.
- Make certain that the spring pin holding the hook nut to the hook is securely in position.
- If hook is equipped with a hook latch or rotational lock, check to determine that they are in good operating condition.
- Check throat opening of the hook. (Refer to Figure 5-2.) It is recommended that upon receipt of the hoist, a measurement be made and recorded of the hook throat opening. OSHA regulations require that the hook be replaced if the throat opening exceeds 15 percent of the original opening, or if the hook is twisted more than 10 degrees from the unbent plane. We suggest that a gage block properly identified to the hoist, similar to the one shown in Figure 5-2, be made for each hook for use in these measurements.

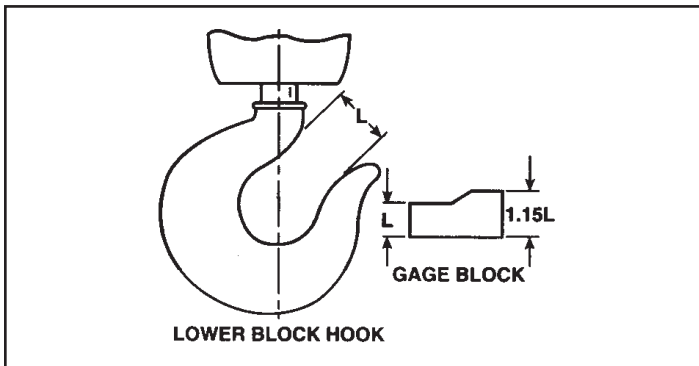

Figure 5-2. Gage Block

- Hooks showing signs of cracks must be replaced. Hooks should be inspected at least once per year using dye penetrants, magnetic particle, or other suitable non-destructive test methods.
- Check wear of the hook, especially at the saddle and replace if worn more than 10% of original dimensions.

5-3. INSPECTION OF UPPER BLOCK

Refer to the Section IX, Figure 9-5.
Upper Block Assembly.

- Check upper block sheaves for wear, damage and freedom of rotation. If sheaves do not rotate freely, disassemble block and inspect bearings. Replace worn or damaged bearings, washers, pins, or sheaves.
- Make certain that all sheaves, bearing and hanger pins are free of foreign material. Bearings without grease fittings are lubricated for the life of the bearing and require no further lubrication.
- Make certain that the rope retention bolts are not bent, loose or otherwise distorted; bolts must have close clearance to sheave flange to keep rope in sheave grooves.

5-4. INSPECTION OF ELECTRICAL CONTROLS

Arrangement of electrical control equipment varies with the type of control, physical space and the optional control features ordered with the hoist.

Note the location in the electrical enclosure of the control circuit fuse, transformer, limit stop switches and the hoist contactors. Trolley contactors and optional hoist and trolley fuses are also located in this enclosure.

Use wiring diagrams furnished with hoist to determine electrical components on your hoist; then determine component location and identity on your hoist.

⚠ WARNING

Be certain that main power switch is locked in open position (OFF) before opening hinged control enclosure cover mounted to the counterweight.

- Open hinged control panel enclosure cover mounted to the counterweight and inspect wiring and terminals. Terminals should be securely crimped to wires and insulation sound. Terminal screws should be tight.
- Check condition of contactor assembly, transformer, and upper limit switches.

5-5. INSPECTION OF ROPE GUIDE

- General. The rope guide is intended to help prevent the rope from "back-winding" and to hold the rope in the proper groove. Side pulling and excessive load swing will severely damage the rope guide and must be avoided.

⚠ WARNING

Side pulling and excessive load swing will severely damage the rope and rope guide. Failure of these components may result in injury.

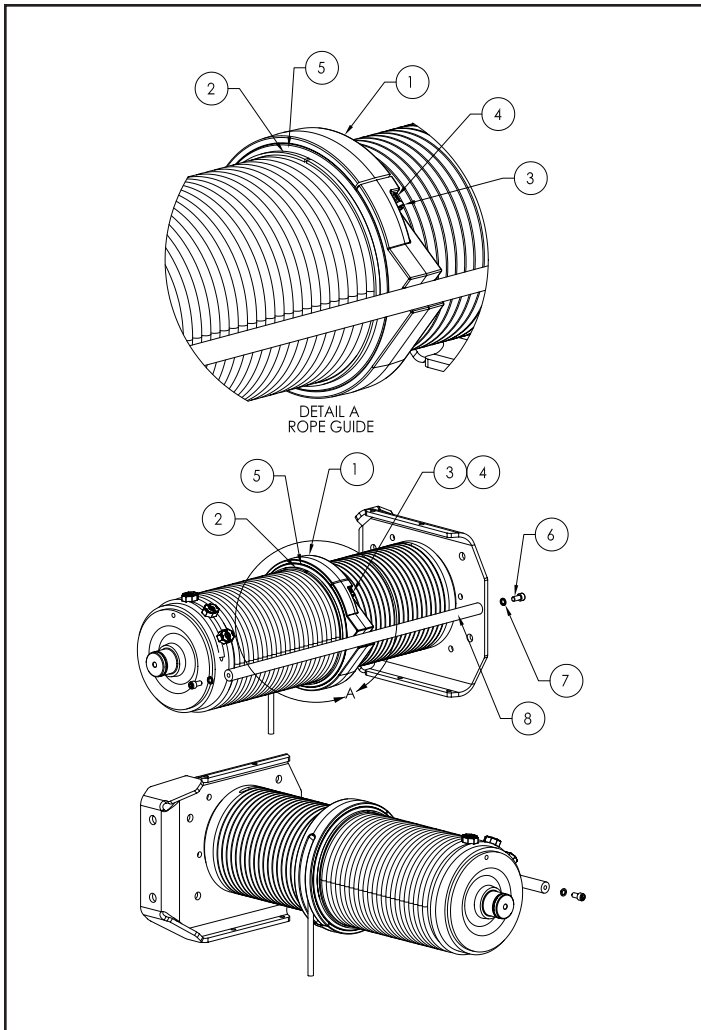

Figure 5-3a Rope Guide Assembly (“B” & “C” Frame)

b) **Disassembly for “B” & “C” Frames.** Refer to Fig. 5-3a. For further assistance in locating components, refer to the parts list in Section IX.

- (1) Remove socket head cap screws and lock washers (Items 6 and 7). Remove drum frame rod (Item 8).
- (2) Remove shoulder bolts (Item 3) and compression springs (Item 4). The two halves of the rope guide body (Item 1) can now be pulled off the drum separately. When reassembling be sure that the half with the rope slot is on the top half of the drum.

⚠ WARNING

Once shoulder bolts are removed, the halves will separate and, if not properly supported, the halves could fall.

- (3) Carefully unhook the rope tensioning spring (Item 5), which is under tension.

⚠ WARNING

The rope tensioning spring is under considerable tension; use caution when unhooking to avoid injury.

- (4) Remove the split plastic shroud (Item 2) from the drum. When reassembling the rope guide, be sure the plastic shroud (Item 2) fits snugly in the rope guide body groove.
 - (5) Thoroughly clean and inspect all components.
 - (6) Follow steps in reverse to reassemble. Be sure to re-grease the rope guide with **MPG** (Paragraph 4-7), after assembling.
- c) **Disassembly for 15 TONNE “D” Frame.** Refer to Fig. 5-3b. For further assistance in locating components, refer to the parts list in Section IX.
- (1) Remove hex head cap screws and lock washers (Items 1 and 2) Pull back on drum frame rod assembly (Item 3) until the free end pulls free of the gearcase end drum bracket.
 - (2) Slide the rope guide assembly (Item 4) off the end of the drum frame rod and remove from drum groove area. Note the required orientation of the rope guide assembly for re-installation.
 - (3) Thoroughly clean and inspect all components.
 - (4) Follow steps in reverse to re-install, paying attention to orientation and making sure to seat the assembly into the correct drum groove. Be sure to regrease the rope guide with MPG (Paragraph 4-7), after assembling.

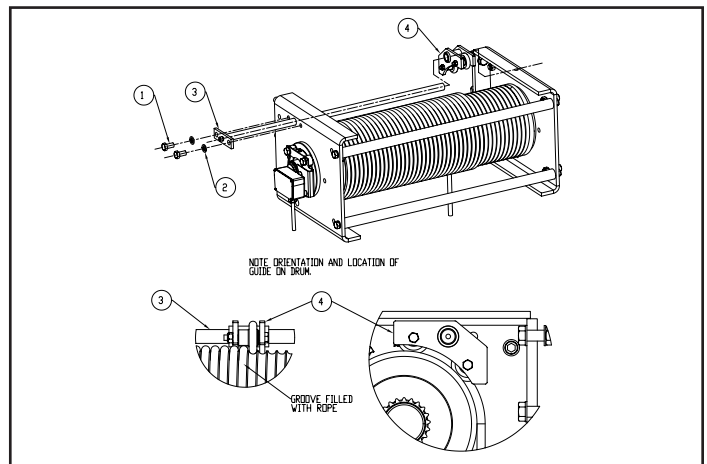

Figure 5-3b. Rope Guide Assembly (15 TONNE “D” Frame)

INSPECTION OF 20 TONNE “D” FRAME WRAP-AROUND ROPE GUIDE

- a) General. The rope guide is intended to help prevent the rope from “back-winding” and to hold the rope in the proper groove. Side pulling and excessive load swing will severely damage the rope guide and must be avoided.

⚠ WARNING

Side pulling and excessive load swing will severely damage the rope and rope guide. Failure of these components may result in injury.

- b) **Disassembly for 20 TONNE “D” Frame.** For further assistance in locating components, refer to the parts list in SECTION IX, Fig. 9-7c.

- (1) Remove all weight and tension from the lower block.

- (2) Remove anti-rotation assembly mounting bolts and lock washers (items H and K). Then loosen mounting bolts and lock washer (items J and K), this will allow the complete removal of the anti-rotation assembly items (F and G). Note the placement and length of mounting bolts (items J and H) improper placement of bolts will result in damage to the rope.
- (3) Remove shoulder bolts (Item D) and compression springs (Item E). The two halves of the rope guide body can now be pulled off the drum separately. When reassembling be sure that the half with the rope slot is on the back side of the drum.

⚠ WARNING

Once shoulder bolts are removed, the halves will separate, and, if not properly supported the halves could fall.

- (4) Carefully unhook the rope tensioning spring (Item C), which is under tension.

⚠ WARNING

The rope tensioning spring is under considerable tension; use caution when unhooking to avoid injury.

- (5) Remove the split plastic shroud (Item I) from the drum. When reassembling the rope guide, be sure the plastic shroud fits snugly in the rope guide body groove.
- (6) Thoroughly clean and inspect all components.
- (7) Follow steps in reverse to reassemble. Torque anti-rotation assembly mounting bolts (items H and J) to between 8 and 10 ft-lbs. Torque shoulder bolts (items D) to between 35 and 36 ft-lb.

5-6. ROPE INSPECTION, MAINTENANCE AND REPLACEMENT

⚠ WARNING

Wire Rope improperly handled or abused can create a SAFETY HAZARD. Read and comply with inspection, maintenance and replacement information given herein.

- a) Inspection. Wire rope on your hoist is one of the most important components requiring frequent inspection and maintenance. All wire ropes will eventually deteriorate to a point where they are not safe and will require replacement. Wire rope should be thoroughly inspected at regular monthly intervals by an authorized person and a determination made when further use of the rope would constitute a safety hazard. Each inspection should include a written dated and signed report of rope condition. Reports should be filed and reviewed each month and any rope deterioration carefully noted. Inspections revealing, but not limited to the following conditions, should cause inspector to question remaining strength of rope and consider replacement. Inspections should take place at the most active sections of the rope, which may be identifiable through visual inspection of rope color. Ropes will wear more quickly in areas that are more frequently in contact with the running sheaves and drum.

- (1) Replace wire rope if the number of visible broken wires exceeds 13 over a length of 6 times the nominal diameter (6d) or exceeds 26 wires over a length of 30d.
- (2) Replace wire rope, if a complete strand has broken.
- (3) Replace wire rope, if rope exhibits swelling, bruises, permanent bends, kinks, crushing, bird-caging or especially heavy wear.
- (4) Replace wire rope, if rope has suffered heat damage from any cause.

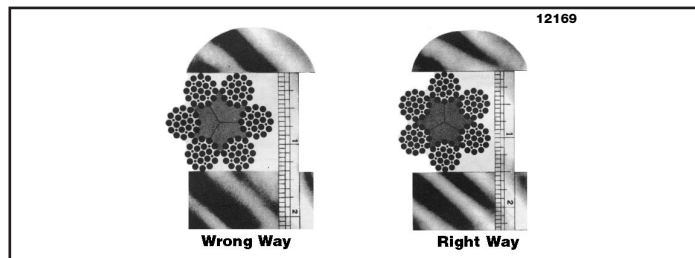

Figure 5-4. Correct Method of Measuring Rope

- (5) Rope corrosion and/or rust formation, internal or external.
- (6) Effects from improper lubrication.
- (7) Rope being idle for one month or more due to shutdown or inactivity.

Special attention should be exercised when inspecting rope normally hidden during inspecting procedures.

Please refer to FEM Section IX, Series Lifting Equipment, namely Section 9.661, "Dimensions and Design of Rope Reeving Components" and ISO 4309, "Wire Ropes - Care, Maintenance, Installation, Examination and Discard", for illustrations and definitions when following the above guidelines for rope inspection.

- b) Maintenance. Keep rope well lubricated to help reduce internal friction and prevent corrosion. Lubricant, as described in Paragraph 4-3, should be applied as a part of the regular maintenance program. Special attention is required to lubricate sections of rope over equalizing sheaves and other hidden areas.

⚠ WARNING

Use only factory-approved rope with swaged wire rope socket.

Avoid dragging ropes in dirt or around sharp objects that will scrape, nick, crush, or induce sharp bends in the rope.

- c) Replacement. When recommended by an authorized inspector, the rope should be replaced. Replacement rope assemblies are shipped from the factory carefully coiled to prevent damage by kinking. Care must be taken to avoid twisting or kinking when uncoiling and handling during reeving.

Before replacing rope, check condition of grooves in sheaves and drums to determine if they are excessively worn.

When first using hoist after rope replacement, break in rope by operating under lighter loads to full travel before applying maximum load.

5-7. ROPE REEVING

- a) General. Place reel on stand with shaft through the center of reel so rope can be pulled straight out with reel rotating.

⚠ WARNING

It is imperative that rope reel or coil rotates as rope unwinds. If coil or reel does not rotate the wire will be twisted as it is uncoiled and kinking will result. A kinked rope is unsafe and must be removed from service.

- b) Before removing the old rope, refer to reeving diagram, Figure 5-5. To assist with re-reeving your hoist, refer to the reeving diagram and corresponding paragraph that describes

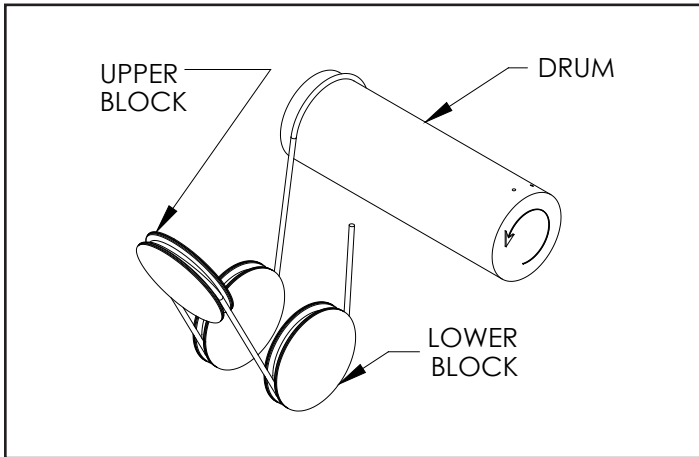

the reeving procedure.

Figure 5-5a. Reeving Diagram - 4 Part Single Reeved.

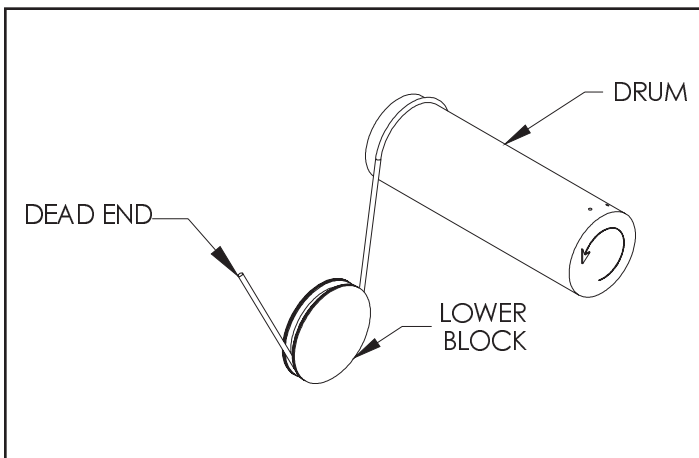

(Note: Arrow on Drum Indicates Direction of Drum when Lowering.)

**Figure 5-5b. Reeving Diagram
2 Part Single Reeved**

- c) Removing old rope. Please refer to Section IX to assist in locating components referred to in the following paragraphs.
- (1) Lower the lower block to a scaffold 6 to 7 feet below hoist to relieve tension on wire rope. (Lower block may be lowered to the floor if desired; however, to handle

⚠ CAUTION

Be certain all personnel are clear of hoist as components, hardware, and wire rope are removed from hoist.

less weight and for ease of reeving, adequate scaffold below the hoist is recommended.)

NOTE

It may be necessary to adjust the geared limit switch in order to completely unwind all of the rope from the rope drum.

⚠ WARNING

Winding rope on rope drums with power can be hazardous. Keep hands safe distance from drum; wear gloves and use extreme care when winding rope.

- (2) Remove the cap screws and hex nuts that retain the lower block sheave covers. Remove covers.
- (3) Remove retaining rings from lower block sheave pin.
- (4) Slide out lower block sheave(s) and remove wire rope.
- (5) Remove two (2) rope retention bolts and nuts from the upper block yoke, as needed.
- (6) Remove one retaining ring on upper block to allow removal of upper block sheave pin.
- (7) Securely grasp the upper block sheave before carefully sliding the sheave pin out. Note that two spacers will Also be released as the pin is removed.
- (8) Remove wire rope from sheave.
- (9) Remove retaining ring(s) and washer from dead end anchor pin. Securely grasp the swaged wire rope before removing the anchor pin.
- (10) Remove rope guide per Section V, Paragraph 5-5.
- (11) Make certain all personnel are clear of hoist and operate hoist "DN" to completely unwind all wire rope from drum. Stop hoist so all (3) rope clamps are accessible. Remove rope clamps and wire rope from drum.

- (b) With the rope lying in the bottom of the drum groove, begin by tightening the rope clamp at the tail end of the rope. Torque the "A" Frame clamps to 12-15 ft.-lbs. (16-20 N-m).
- (c) Applying tension to the rope and keeping it properly seated in the drum groove, install the remaining two clamps to the specified torque above.
- (2) With all personnel clear of hoist - TURN ON POWER.
- (3) Operate hoist "UP" guiding six (6) wraps of new rope into drum grooves with gloved hand.

d) Installing new rope.

⚠ WARNING

Geared limit switch must be reset after replacing wire rope. Check limit switch operation carefully, without load, before placing hoist in service. SEVERE DAMAGE AND/OR A DROPPED LOAD COULD RESULT. Allow 3" for hook drift in both directions. Do not allow less than two (2) complete wraps of rope on drum with hook in lowest position.

⚠ WARNING

The hoist must be removed from service and placed on the ground for any maintenance that requires removal of the output shaft assembly or drum.

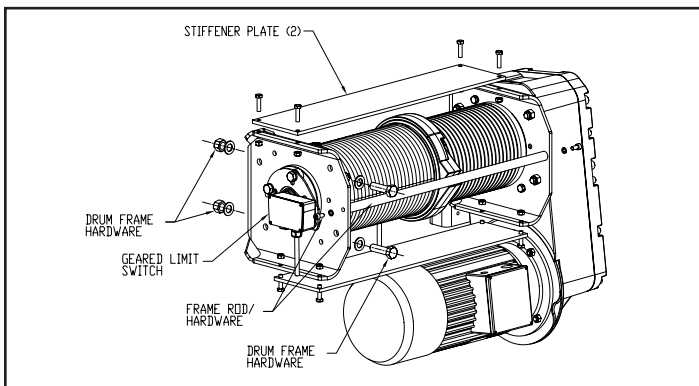
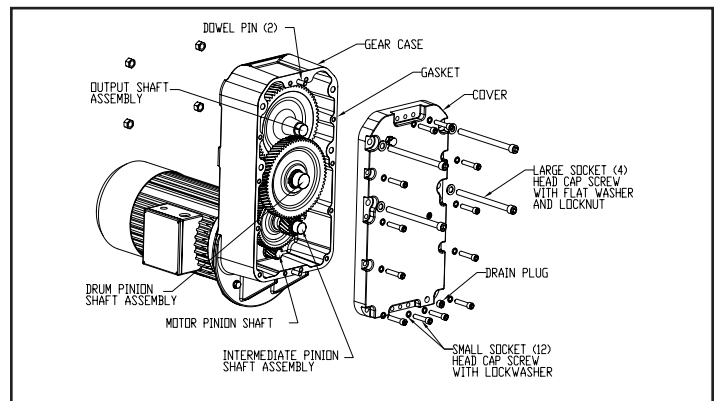

- (1) Thread rope to drum from trolley frame side then secure with rope clamps as follows:
 - (a) Make sure that the rope clamp is orientated such that the clamp grooves capture and fully seat the rope in the drum grooves. The clamps are designed for use specifically with the 6.4mm wire rope that was supplied with your "A" Frame hoist.

- (4) Reinstall rope guide over rope in rope drum grooves as shown in Figure 5-3a. & 5-3b. and outlined in Section V, Paragraph 5-5. Continue lubricating as rope is spooled onto the drum until about 24'-0" remain unwound.
- (5) With outer lower block covers removed, thread the wire rope through the sheaves of the upper and lower block as shown in Figures 5-5a and 5-5b.
- (6) Attach swaged rope end to the dead end anchor pin and fasten with the retainer rings provided with the hoist.
- (7) Replace the lower block sheave covers.
- (8) Lubricate cable per Paragraph 4-3.
- e) Checking for and removal of rope twisting.
 - (1) To remove rope twist in "A" Frame single reeved hoists:
 - (a) Observe direction block tends to rotate.
 - (b) Lower the block to a low position and TURN OFF (lock out) POWER.
 - (c) Remove swaged fitting from anchor pin and rotate rope several turns in a direction tending to correct block rotation.

 WARNING

If output shaft assembly is pulled out of the gear case with the cover, it will disengage from the drum allowing the drum to drop. Be certain all shaft assemblies stay in the case.

- (d) TURN ON POWER; raise and lower the block several times to feed the correcting twist in the rope through the reeving.

Figure 5-6. Drum Frame & Geared Limit Switch ("B" & "C" Frame Shown)

 WARNING

The hoist must be removed from service and repaired on the ground for any maintenance that requires removal of the output shaft assembly or drum.

5-8. INSPECTION OF ROPE DRUM AND SHAFT

- a) To remove the rope drum, remove the rope guide and hoisting cable, as outlined in Section V, Paragraphs 5-5. and 5-7.c., respectively.
- b) Remove the geared limit switch or disconnect the wires so that the electrical cable will not inhibit removal of the drum. (see Figure 5-6).
- c) Remove the hoist from the beam, place it on the ground and provide adequate means to support the drum before removing the frame rod cap screws and rods at the outboard end drum frame (see Figure 5-6).
- d) The hardware attaching the drum frame to the hoist and trolley frame may then be removed. Access the drum frame hardware (locknuts) from the clearance holes on the side, opposite that of the drum, of the load girt.
- e) Keeping the drum level, remove the drum from the splined output shaft at the gear case end.
- f) Inspect the gearcase output shaft and drum splines for wear.
- g) Before re-assembling, by reversing above instructions, make sure to apply a liberal amount of SG (Paragraph 4-7) spline grease to both the output shaft and drum splines. Torque "A" Frame drum mounting bolts to 60-80 ft.-lbs. (81-108 N-m).

5-9. INSPECTION OF HOIST GEARING

Figure 5-7. Hoist Gear Case Assembly ("B" & "C" Frame)

- a) General. The hoist gear case is a triple-reduction, splash lubricated, vertically split, cast aluminum case and cover. A helical gear train provides smooth and quiet hoisting

NOTICE

Failure to use a factory replacement seal will cause premature seal failure due to specific lip material requirements that must be met.

operation. The gear shafts are supported with ball and roller bearings housed in the back of the case and in the cover. The input pinion is integrated onto the motor shaft. An oil seal housed in the gear case at the motor input seals the motor shaft as it passes into the gear case. Since the entire motor shaft is submerged in oil, anytime the motor is removed, the oil must be drained from the gear case. All pinions are integral with their shafts while the gears are keyed and pressed onto their shafts, with exception of the integral output shaft. The output shaft passes through an oil seal in the back of the gear case and drives the drum by means of a crowned spline. One end of the rope drum is supported on this output shaft.

b) Inspection and Disassembly.

Gearcase. (See Figure 5-7.)

- (1) Lower hook block to the floor and relieve all load from ropes.
- (2) Make sure power to hoist is off and locked out.
- (3) Drain the oil from the gear case per Section IV, Paragraph 4-2.
- (4) On the "A" Frame hoist, the bolts supporting the gearcase are installed through tabs on the outside of the housing and do not pass through the gearcase cover. These bolts are not to be removed, unless the entire gearcase assembly is being removed from the hoist.
- (5) Provide adequate means to support the gearcase cover. Remove the smaller socket head cap screws

Do not attempt to assemble the cover to the gear case without a gasket, as the spacing between bearings will be reduced. Severe damage to the hoist will occur if no gasket or the wrong gasket is used. Refill gear case with new lubricant per Section IV, Paragraph 4-2 before use. Using SG (Paragraph 4-7), grease the spline teeth on the output shaft before reinstalling rope drum.

- (10) Test hoist per Section V, Paragraph 5-14 to ensure proper lubrication.

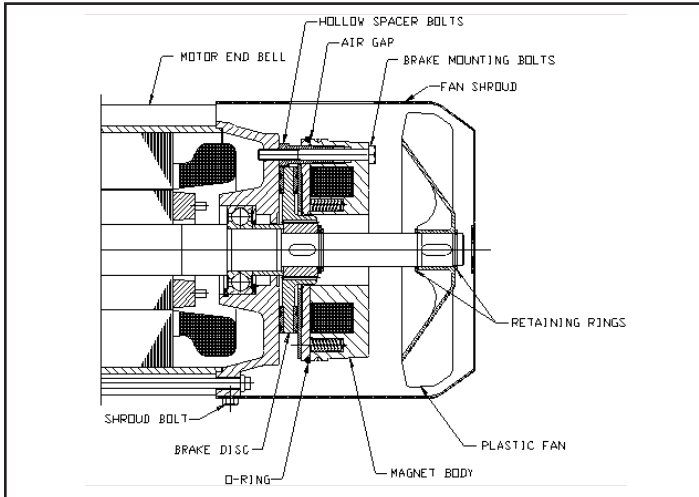

and lockwashers holding the cover to the gearcase. Carefully draw the cover directly away from the gearcase, as damage to this surface will prevent the gasket from sealing properly. If needed, lightly tap on the top and bottom cover tabs to release. As the cover is removed, ensure that all gear and shaft assemblies remain in the

⚠ WARNING

Check to be certain main power switch is locked in open position (OFF), before removing fan shroud.

case and are fully supported by the gearcase bearings.

- (6) If it is necessary to remove the output shaft assembly from the gear case, the rope drum must first be removed from the hoist. See Section V, Paragraph 5-8. Only once the output shaft is free of the rope drum, can the output shaft assembly be safely removed from the gearcase. Provide an adequate means to support this shaft and gear assembly before removing, as it is heavy. The "A" Frame gear assembly weighs 14 lbs.
- (7) The pinion shaft and gear assemblies may be removed as necessary.
- (8) Inspect all gears, pinions, bearings, and the output shaft spline for wear, pitting, or mechanical damage. Replace the gearcase assembly, as necessary. Thoroughly clean the output shaft external spline teeth before reassembly.
- (9) Assembly is opposite of removal. Use a new gasket.

Hoist Motor.

- (1) Lower hook block to the floor and relieve all load from ropes.
- (2) Make sure power to hoist is off and locked out.
- (3) Drain the oil from the gear case per Section IV, Paragraph 4-2.
- (4) Disconnect the wiring and conduit from the motor junction box.

motor seats properly into the rabbet fit machined in the gear case. Fasten the motor to the gear case.

- (10) Reconnect the conduit and power leads to the motor. See Section VIII and refer to the specific wiring diagrams shipped with your hoist.
- (11) Refill gear case with lubricant per Section IV, Paragraph 4-2.
- (12) Test hoist to ensure proper operation per Section V, Paragraph 5-14.

5-10. INSPECTION OF MOTOR BRAKE AND ACTUATING MECHANISM

(1) ABM Motor Brake

- a) General Operation. The hoist brake is an electro-magnetically released, spring set non-adjustable brake. Torque is generated by compressing a friction disk between the stationary motor end bell and the spring loaded brake armature. The friction disk is fixed to and rotates with the motor shaft. When the magnet coil is energized, the armature plate is pulled across the air gap. The friction disk is carried by a splined hub that permits axial movement when the brake is released. This axial movement releases both sides of the friction disk from their mating stationary surfaces and allows the friction disk to rotate freely when the brake is energized. When power is removed from the magnetic coil, the compression springs push the armature against the friction disk and the other side of the friction disk against the motor end bell generating the torque necessary to stop the hoist machinery and hold the load.

It will be necessary to compensate for the friction disk wear when a greater amount of hook movement (drift) is noticed when stopping. There is no torque adjustment of the brake. Friction disk wear can only be compensated for by resetting air gap.

Figure 5-8a. ABM Motor Brake

b) Friction Disk Inspection and Air Gap Adjustment.

- (1) Lower hook block to the floor and relieve all load from ropes.
- (2) Make sure power to the hoist is off and locked out.
- (3) Remove the four (4) bolts attaching the fan shroud to the motor and remove the fan shroud. See Figure 5-8.
- (4) Carefully roll the large O-ring from the groove over the air gap back toward the magnet body. Do not excessively stretch this O-ring.
- (5) Measure the air gap using feeler gages. If the air gap exceeds the maximum value shown in Table 5-1a, the air gap must be reset.
- (6) To measure the thickness of the friction disk, it is necessary to remove the brake body from the motor end bell. Remove the three (3) brake mounting bolts and draw the brake body away from the friction disk. Carefully set the brake body down on the motor shaft directly in front of the fan. Draw the friction disk away from the end bell and measure the thickness across the friction surfaces. If the friction disk thickness is less than the minimum shown in Table 1, it must be replaced. See Section IX, Figure 9-8. If the friction disk thickness is within the allowable, reassemble the brake body to the motor end bell and torque the mounting bolts to the value shown in Table 5-1a. Whenever the friction disk is replaced, it is necessary to reset the air gap.

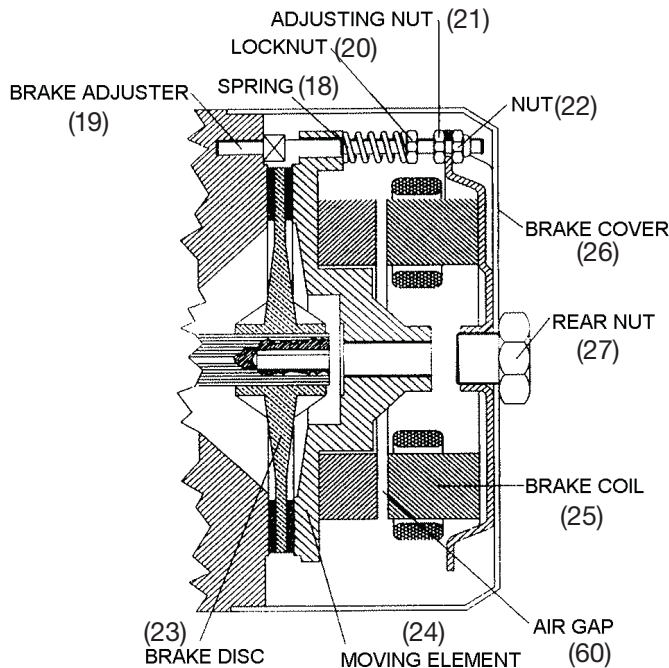

- (5) Provide a means to support the hoist motor. The "A" Frame S4 hoist motor weighs approximately 70 lbs. and the S2 hoist motor weighs approximately 50 lbs. The motor must be adequately supported and held horizontally while removing and installing, to avoid input seal damage.
- (6) Once the motor is properly supported, remove the hardware fastening it to the gear case. Carefully withdraw the motor horizontally straight out from the gear case. Do not tip or move the motor from side to side.
- (7) Replace the motor shaft seal using an appropriate seal driver. It is recommended that a new seal be installed each time the motor is removed from the case.

IMPORTANT!

- (8) Before reinstalling the motor, pack the gear teeth with MPG grease (Paragraph 4-7) and wrap the gear teeth with a number of layers of Teflon tape to protect the seal lip from being damaged by the gear teeth. Coat the seal lip and the motor shaft with MPG grease.
- (9) Install the motor to the gear case. The motor shaft must be in line with the seal bore and perpendicular to the mounting surface before attempting to insert the shaft through the seal. The motor shaft must remain horizontal and not rock up and down or side-to-side while installing the motor or seal damage will occur. It may be necessary to rotate the rope drum slightly to align the gear teeth to mesh with the teeth on the motor shaft. Ensure that the

Hoist	"B" Frame	"C" Frame	"D" Frame
Mounting Bolt Torque	7.5 ft-lbs. (10 Nm)	18 ft-lbs. (25 Nm)	18 ft-lbs. (25 Nm)
Minimum Air Gap	0.012 in. (0.3 mm)	0.016 in. (0.4 mm)	0.016 in. (0.4 mm)
Maximum Air Gap	0.031 in. (0.8 mm)	0.043 in. (1.1 mm)	0.043 in. (1.1 mm)
Minimum Brake Disk Thickness	0.335 in. (8.5 mm)	0.472 in. (12.0 mm)	0.472 in. (12.0 mm)

Table 5-1a. ABM Motor Brake Data)

- (7) To reset the air gap, begin by releasing the (3) mounting bolts 1/2 turn. Turn the hollow spacer bolts into the magnet body approximately 1/4 turn. Retighten all three mounting screws. Measure the air gap at a minimum of three places around the circumference. Threading the hollow spacer bolts into the magnet body will decrease the air gap, while backing these spacer bolts out of the magnet body will increase the air gap. Repeat this step, as necessary, until the required air gap is achieved. The air gap must be the same all the way around the brake. Once the air gap is correct, torque the mounting bolts to the value shown in Table 5-1.
 - (8) Replace the large O-ring over the air gap and reassemble the fan shroud to the motor.
 - (9) Test hoist per Section V, Paragraph 5-14 to ensure proper brake operation.
- c) **Brake Disassembly.**
- (1) Lower hook block to the floor and relieve all load from ropes.
 - (2) Make sure power to the hoist is off and locked out.
 - (3) Remove the four (4) bolts attaching the fan shroud to the motor and remove the fan shroud. See Figure 5-8.
 - (4) Remove the snap ring behind the plastic fan. Carefully remove the fan and key from the motor shaft. Remove the snap ring in front of where the fan was mounted.
 - (5) Disconnect the two wires from the terminal block on the magnetic body.
 - (6) Remove the three mounting bolts that attach the brake body to the motor end bell and remove the brake body from the motor. Remove the friction disk from the motor shaft.
 - (7) Clean and inspect all components and working surfaces. Replace all damaged or worn components as necessary. Measure friction disk thickness and replace if less than the minimum thickness shown in Table 5-1a.
- d) **Brake Re-assembly.**
- (1) Install the friction disk on the splined hub. The friction disk must slide on the splined hub and seat against the end bell of the motor.
 - (2) Install the brake body to the motor end bell using the three (3) mounting bolts. The air gap must be reset as described in Section V, Paragraph 5-10.b. Torque the mounting bolts to the values shown in Table 5-1a. Install the large O-ring in the groove over the air gap. Ensure this O-ring is not pinched in the air gap.
 - (3) Connect the brake leads to the terminal block on the brake body.
 - (4) Install the forward fan mounting retaining ring and install

the fan. Install the rear retaining ring. Install the fan shroud and bolts.

- (5) Test hoist per Section V, Paragraph 5-14.

Figure 5-8b. MGM Motor Brake

(2) MGM Motor Brake

- a) **General Operation.** The hoist brake is an electro magnetically released, spring set adjustable brake. Torque is generated by compressing a friction disk between the stationary motor end bell and the spring loaded brake armature. The friction disk is fixed to and rotates with the motor shaft. When the magnet coil is energized, the armature plate is pulled across the air gap. The friction disk is carried by a splined hub that permits axial movement when the brake is released. This axial movement releases both sides of the friction disk from their mating stationary surfaces and allows the friction disk to rotate freely when the brake is energized. When power is removed from the magnetic coil, the compression springs push the armature against the friction disk and the other side of the friction disk against the motor end bell generating the torque necessary to stop the hoist machinery and hold the load.

It will be necessary to compensate for the friction disk wear when a greater amount of hook movement (drift) is noticed when stopping. There is no torque adjustment of the brake. Friction disk wear can only be compensated for by resetting air gap.

Verify that all motor and brake supply terminals are properly tightened to the terminal board as well as the earthing terminal to the motor frame. As a result of normal wear of the brake disc lining, check that the air gap does not exceed the values shown on table 1. Please note that the brake linings wear is greater during the run-in. (few thousands stops). For the air gap adjustment, follow the instructions given into the paragraph "Air Gap Adjustment". Check the wear on both friction surfaces of the brake disc (on one side only for BAPV series) to be sure that their thickness is not less than 2 mm. Verify also that there are no damages on disc surfaces and in particular, in the hub toothing. (For replacement, refer to the paragraph "Brake Disc" Replacement"). For those brake disc with rivets on disc lining verify that braking surface has not reached the rivets; moreover check that no play should be between the brake disc and the brake disc hub in correspondence of the hub nails. Verify periodically that the braking torque is suitable. If needed, proceed to its adjustment as stated in the paragraph "Braking Torque Adjustment". Verify regularly the brake adjuster (19-42) wear conditions and their steady fastening on the rear cover brake Figure 5-8b. MGM Motor Brake surface (17). All brake assembly components, in particular the brake disc (23, 39-41 for BAF series, 45 for BAPV) and the brake adjusters (19, 42 for BAF-BAPV series) are subject to wear. In consideration of safety it's needed to replace them periodically. The replacement frequency comes from the motor duty (number of start/stop, applied moment of inertia, environment conditions and so on), we recommend however to replace them at least every 18 months. Periodically check and verify the shaft splines wear, exactly where the disc slides.

Braking Torque Adjustment. The brake torque is proportional to the spring (18) compression. The compression of the springs must be as uniform as possible. Spring height "H" must be maintained to ensure proper brake torque. As the friction disc wears, the spring

height and air gap must be adjusted. To prevent damage to the brake, do not over compress the springs. If the brake coil (25) is not able to call the brake moving element (24) back with a quick stroke and keep it attracted without vibrations, verify the exact air gap adjustment and if this inconvenience still persists, loosen the locknut (20) and try it again until desired functioning is obtained. After every intervention please verify that "H" Dim is correct. Never exceed the maximum braking torque value stated on the motor name plate. It's recommended to avoid adjusting the braking torque to values lower than 30% of the maximum value.

Brake Disc Replacement. Loosen the rear nut (27), remove the end cover (26) and unscrew the locknuts (22).

CAUTION

Damage to the hoist may occur if the block operated limit switch fails during testing.

Damage can be avoided by immediately releasing the pushbutton once the lower block has traveled through the limit switch weight.

Take off the brake coil (25) from the brake adjusters (19), remove the nuts (20-21) and the springs (18). Remove the brake moving element (24) sliding it through the brake adjusters (19). Take off the old brake disc (23) and put in the new one. For re-assembling, proceed backwards. We recommend that the new brake disc must be handled with clean hands, because even a small trace of grease will decrease the braking performance and also increase noise. In the BAF series otherwise than in the BA series there are 2 brake discs (39-41) with an intermediate brake moving element (40) in between. After the brake coil (25) replacement, proceed to the air gap adjustment (see the pertinent paragraph). For the flywheel (45) replacement on the BAPV series, follow up the specific instructions.

WARNING

Check limit switch operation carefully, without load, before placing hoist in service. If misadjusted, SEVERE DAMAGE AND/OR A DROPPED LOAD COULD RESULT. Allow 3" for hook drift in both directions. Never allow less than two (2) complete wraps of rope on drum with hook in lowest position.

Hoist	"A" S2	"A" S4
Brake Adjuster Stud Torque	N/A	15.49 ft-lbs. (21 +/-2 Nm)
Minimum Air Gap	N/A	0.012 in. (0.3 mm)
Maximum Air Gap	N/A	0.024 in. (0.6 mm)
Minimum Brake Disk Thickness	N/A	0.079 in. (2 mm)
Spring Height "H"	N/A	15 mm

Table 5-1b. Motor Brake Data (MGM Motor Brake)

Brake Coil Replacement. Loosen the rear nut (27), remove the end 5-11. INSPECTION OF HOIST TRAVERSE DRIVE cover (26), disconnect the brake coil (25). Unscrew the locknuts (22) and pull off the brake coil (25) from brake adjusters (19). Reassemble the new brake coil on the brake adjusters (19) and reconnect the electrical connectors. Pay attention to place the electrical connectors in the right position so that to allow their insertion. Before reassemble the end cover (26) and the nuts verify that the connections and relative cables are properly tightened. Proceed with the air gap adjustment as stated in the respective paragraph. Verify that the brake coil functions correctly; when the brake is energized, the brake coil (25) should attract the brake moving element (24) with a quick stroke, and hold it without any vibration or noise. In case of any vibration, check that terminal connectors are coupled correctly and tightly.

Air Gap Adjustment.

The air gap *(60) i.e. the distance between the two magnetic cores of the brake coil (25) and the brake moving element (24), must be as shown on Table 5-1b. It's strongly unadvisable to exceed these values in order to avoid vibrations of the brake moving element, prominent noise, the burning of the brake coil or the brake assembly damaging. It's advisable to check periodically the air gap, because the wear of the brake disc linings, it tends to increase. Please note that the brake linings wear is greater during the run-in (few thousand stops). In order to set the air gap back to the required value, operate on the nuts (21-22) to obtain the brake coil forward displacement towards the brake moving element (24). It's strongly recommended to avoid to tighten

WARNING

Working in or near exposed energized electrical equipment presents the danger of electric shock.

TO AVOID INJURY:

DISCONNECT POWER AND IMPLEMENT LOCKOUT/TAGOUT PROCEDURE BEFORE REMOVING COVER OR SERVICING THIS EQUIPMENT.

the locknut (22) located on one brake adjuster (19, 42 for BAPV-BAF series motors) before having completed the positioning of the brake coil (25) on all the brake adjusters. Therefore don't regulate the position of the brake coil adjusting the nut (21) on one brake adjuster, if previously you didn't loose the locknuts (22) on all the brake adjusters (19, 42 for BAPV-BAF series motors). This wrong operation could stress the air gap adjusters. Please verify that the air gap is uniform. The air gap must be uniform to guarantee the right working and avoid mechanical stresses due to a wrong alignment. When the air gap adjustment has been settled, the locknuts (22) should be tightened. For brake

SECTION VI - TROUBLESHOOTING

TROUBLE	PROBABLE CASE	REMEDY
6-1. Hoist Will Not Operate	a. No power to hoist	a. Check switches, circuit breakers or fuses and connections in power supply lines. Check power collectors.
	b. Wrong voltage	b. Check voltage required on motor data plate against power supply.
	c. Loose or broken wire connections in hoist electrical system	c. Shut off and lock out power supply; remove electrical cover on hoist and check wiring connections. Also check connections in push button station and limit switches.
	d. Contactor assembly not functioning	d. See that necessary jumper wires are properly installed. Verify that the contactor armatures are free to move. If binding occurs, replace contactor. Check for burned out contactor coils.
	e. No control voltage	e. Check transformer fuse. If blown, check for grounding and/or shorts in the push button station. Check the transformer coil for signs of overheating. Replace transformer if burned out. Verify the transformer secondary is the same voltage as the coils to which it is connected.
	f. Motor burned out	f. Replace motor. Check input power supply. Check hoist motor connections.
	g. Reverse phasing on three-phase hoists	g. Check phase protection device (PPD), if amber LED is steady; interchange any two power supply line leads per Section II, Paragraph 2-4.b.
6-2. Hook Moves in Wrong Direction	a. Reverse phasing on three-phase hoists	a. Check PPD, if green LED is steady; interchange any two sets (each winding) of motor power leads.
	b. Hoist wired incorrectly	b. Check wiring connections with appropriate wiring diagram.
6-3. Hook Will Raise But Not Lower	a. Lower electrical circuit open	a. Check for loose connections. See that necessary jumper wires are properly installed on contactor.
	b. Contactor assembly not functioning	b. See that necessary jumper wires are properly installed. Verify that the contactor armatures are free to move. If binding occurs, replace contactor. Check for burned out contactor coils.
	c. Down, push button inoperative	c. Check push button contacts and wires.

SECTION VI - TROUBLESHOOTING

TROUBLE	PROBABLE CASE	REMEDY
6-4. Hook Will Lower But Not Raise	a. Excessive load	a. Reduce loading to rated load of hoist, as shown on nameplate.
	b. Hoist electrical circuit open	b. Check for loose connections. See that necessary jumper wires are properly installed on contactor.
	c. Contactor assembly not functioning	c. See that necessary jumper wires are properly installed. Verify that the contactor armatures are free to move. If binding occurs, replace contactor. Check for burned out contactor coils.
	d. Up, down button inoperative	d. Check push button contacts and wires.
6-5. Hoist Will Not Lift Rated Load	a. Low voltage	a. See that power supply current is the same voltage listed on motor data plate. Check hoist motor connections. Check size of power supply lines.
6-6. Hoist Motor Overheats	a. Excessive load	a. Reduce loading to rated load as shown on nameplate.
	b. Excessive duty-cycle	b. Reduce frequency of lifts or amount of jogging.
	c. Wrong voltage or frequency	c. Check current rating on motor data plate against power supply. Check hoist and inspect for defective, worn or damaged parts.
	d. Defective motor or worn bearings in hoist frame	d. Disassemble hoist and inspect for defective, worn or damaged parts.
	e. Brake not adjusted properly	e. Adjust brake per Section VII, Paragraph 7-1.
6-7. Load Drifts Excessively When Hoist Is Stopped	a. Excessive load	a. Reduce loading to rated load, as shown on nameplate.
	b. Motor brake not holding	b. With No Load, check hoist for drift. If drifting is excessive, inspect motor brake (Section V, paragraph 5-10) and adjust as outlined in Section VII, paragraph 7-1.
6-8. Hoist Operates Intermittently	a. Collectors make poor contact	a. Check collectors for free movement of spring arm, weak spring or electrical connections.
	b. Loose connections	b. Check all wiring for loose connections.

SECTION VII - ADJUSTMENTS

7-1. MOTOR BRAKE ADJUSTMENT

These brakes are designed so that adjustment is seldom required. If, after a period of service, the load hook “drifts” downward more than usual for your hoist before coming to a stop, the motor brake may require adjustment to compensate for brake disc wear.

WARNING

Check to be certain main power switch is locked in open position (OFF) before removing brake cover.

Refer to Figure 5-9 and proceed as outlined in Section V, Paragraph 5-10.

7-2. BLOCK OPERATED LIMIT SWITCH ADJUSTMENT

The block operated limit stop is minimally adjustable and designed to stop the lower block at the safest high point of travel to eliminate any possibility of double-blocking. When the safest high point is reached, the limit switch automatically stops hook travel. If the block switch is not tripping after contact with the lower block body, loosen the limit switch hub retaining screw and rotate the hub and rod downward to ensure earlier contact. Retighten and test, repeat as needed until switch functions properly.

7-3. GEARED ROTARY LIMIT SWITCH ADJUSTMENT

The geared rotary type limit switch is standard equipment and is located on the drum end opposite the gearcase end.

This limit switch has a rotary screw driven by a gear reduction that is coupled to the end of the drum shaft. Adjustment discs operate the contacts of separate switches, one for the hoisting circuit and one for the lowering circuit. The switch assembly must be wired in accordance with the appropriate wiring diagram, which is shipped with the hoist. Instructions for adjusting limit switch are inside cover and are repeated below (see Figure 7-2).

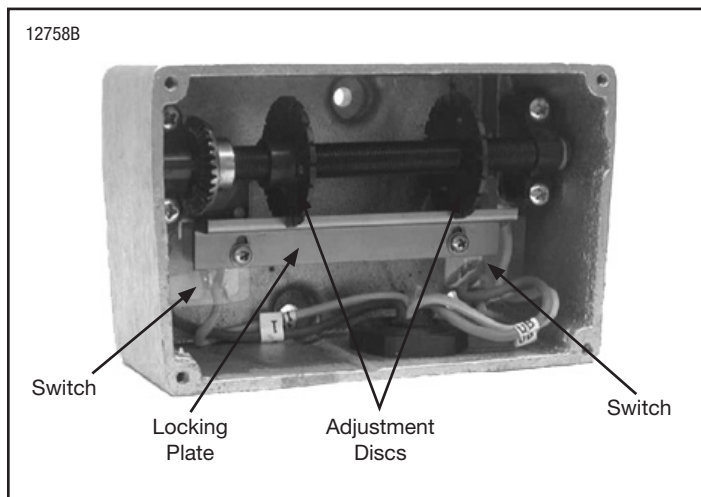

Figure 7-2. Screw-Type Limit Switch Adjustment (Wires Not Shown for Clarity.)

WARNING

Be certain that electrical power supply is OFF and locked in the open position before removing limit switch cover.

- Remove four screws and lift off switch cover.
- Loosen locking plate screws. Slide locking plate away from adjustment disc.
- Turn proper adjustment disc (right for up, left for down) toward switch to reduce hook travel or away from switch to increase hook travel.
- Slide locking plate back into position ensuring slots on adjustment discs are fully engaged, tighten locking plate screws to 4 in-lbs.
- Replace cover.
- Carefully check limit switch operation without load before placing hoist in service. If misadjusted, repeat steps above. Allow 3” for hook drift in both directions. Never allow less than two (2) complete wraps of rope on drum with hook in lowest position.

WARNING

Check limit switch operation carefully, without load, before placing hoist in service. If misadjusted, SEVERE DAMAGE AND/OR A DROPPED LOAD COULD RESULT. Allow 3” for hook drift in both directions. Never allow less than two (2) complete wraps of rope on drum with hook in lowest position.

Provide a light film of **MPG** grease (Paragraph 4-7) on gear of both limit switches.

7-4. OVER-CAPACITY LIMIT SWITCH ADJUSTMENT

The over-capacity limit switch is standard equipment and is integrated into the wire rope dead end assembly (see Figure 7-3). The device is designed to prevent overloading of the equipment, but is not intended to be used as a load-measuring device.

The limit switch is factory preset to prevent the lifting of loads weighing 125-150% of rated capacity. At times, it may be necessary to adjust the limit switch setting.

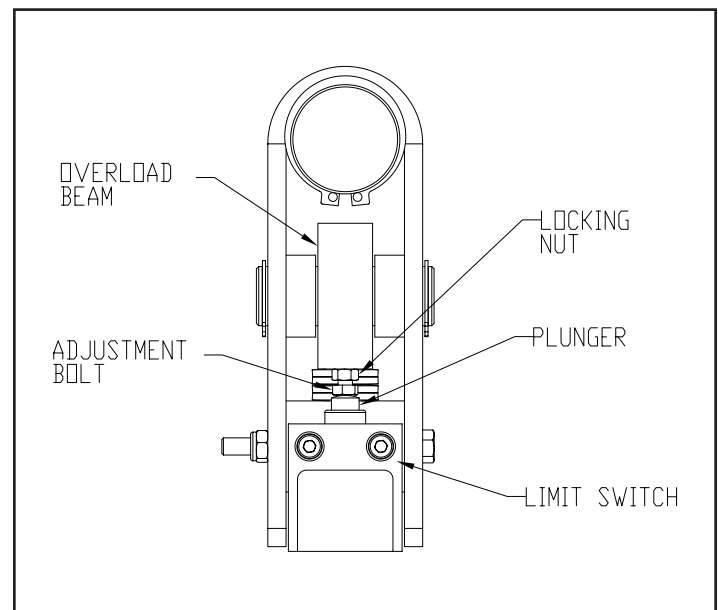

Figure 7-3a. Over-Capacity Limit Switch (‘B’ & ‘C’ Frames)

FIGURE 8-1. ELEMENTARY WIRING DIAGRAM FOR A TWO-SPEED HOIST AND TROLLEY WITH STANDARD FEATURES

ELEMENTARY DIAGRAM

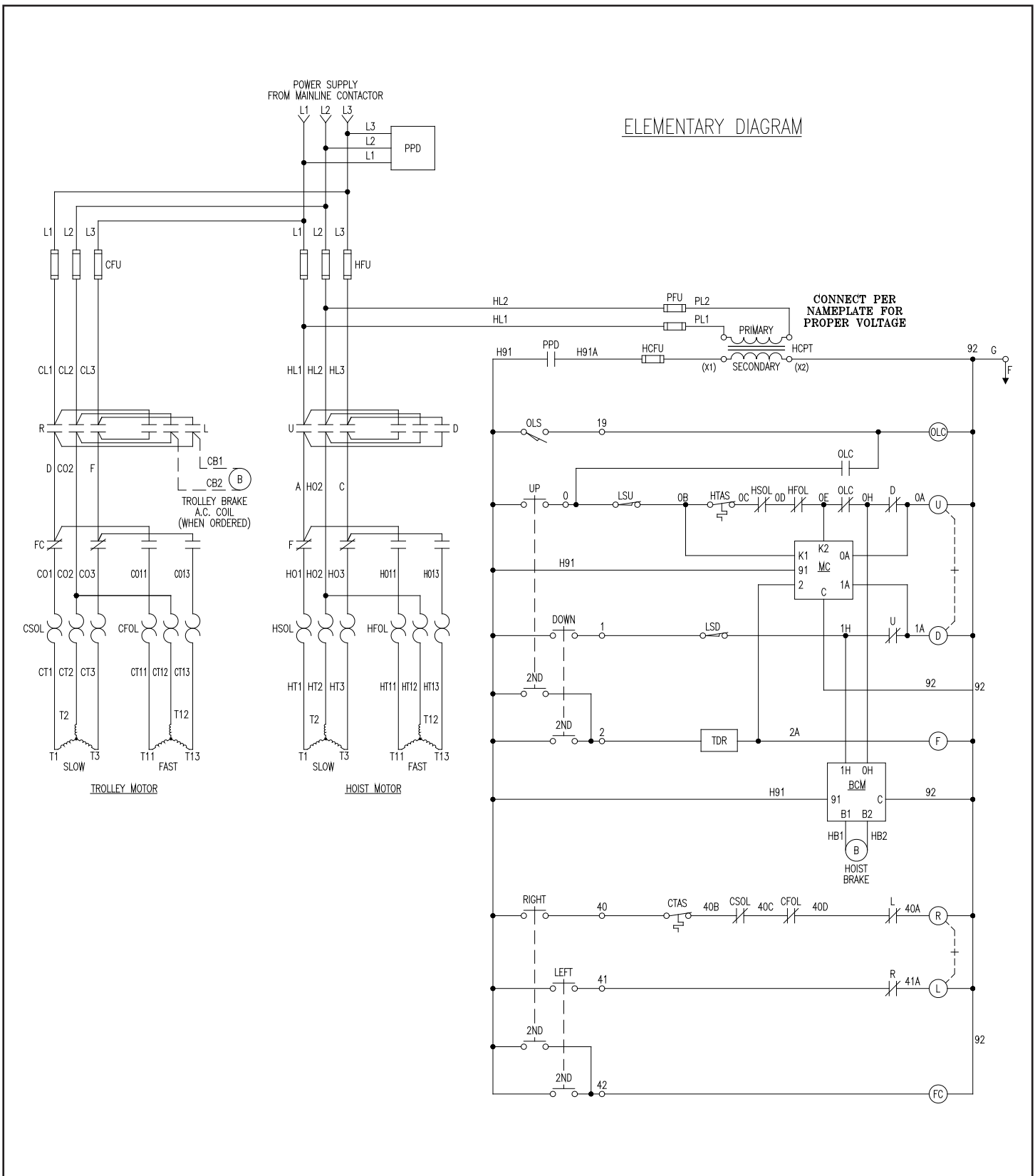
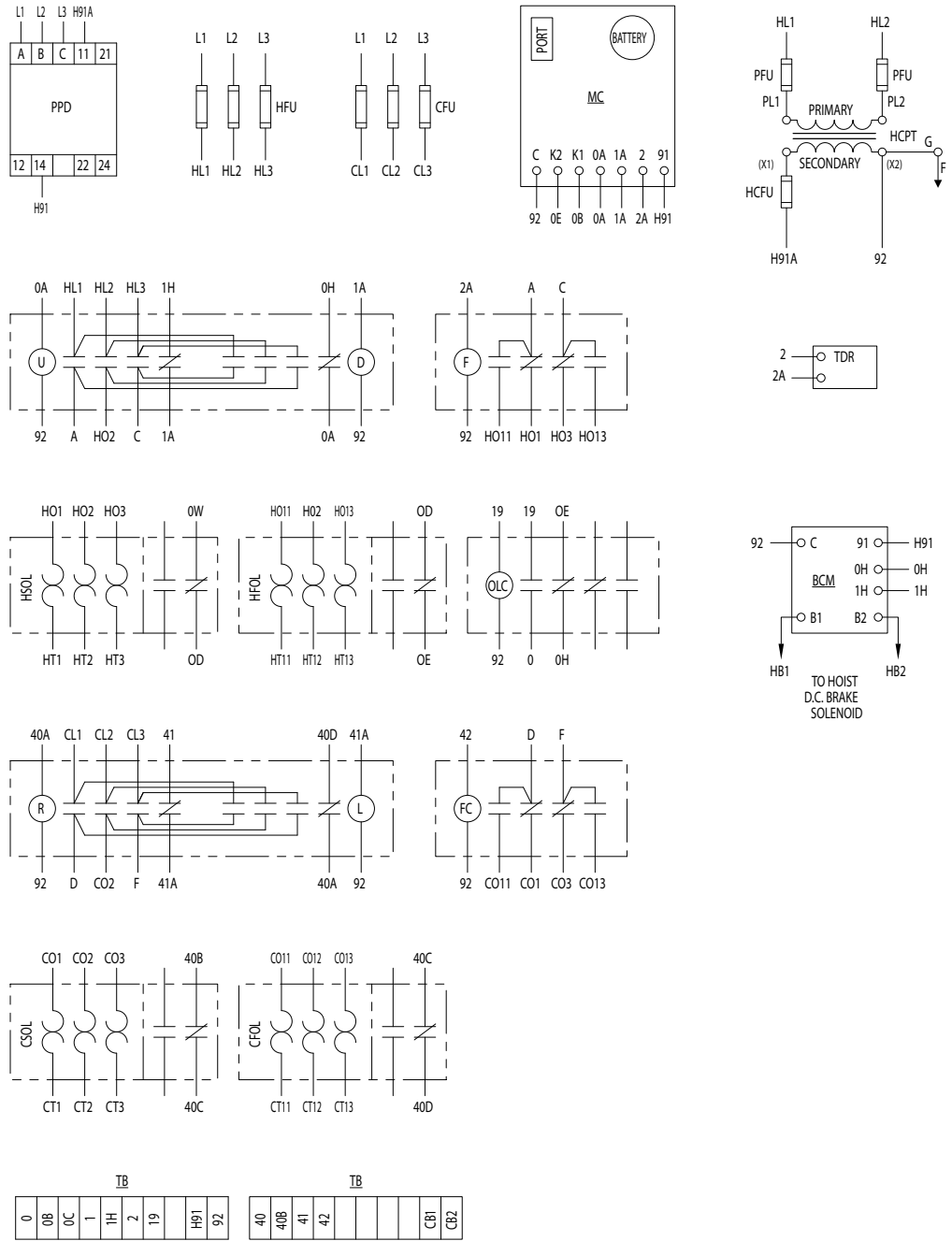

FIGURE 8-2. COMPONENT DIAGRAM FOR A TWO-SPEED HOIST AND TROLLEY WITH STANDARD FEATURES

WIRE #	DEVICE CONNECTED
L1	HFU, CFU, PPD
L2	HFU, CFU, PPD
L3	HFU, CFU, PPD
HL1	HFU, U-D, PFU
HL2	HFU, U-D, PFU
HL3	HFU, U-D
CL1	CFU, R-L
CL2	CFU, R-L
CL3	CFU, R-L
PL1	PFU, HCPT
PL2	PFU, HCPT
A	U-D, F
C	U-D, F
D	R-L, FC
F	R-L, FC
HO1	F, HSOL
HO2	U-D, HSOL, HFOL
HO3	F, HSOL
HO11	F, HFOL
HO13	F, HFOL
CO1	FC, CSOL
CO2	R-L, CSOL, CFOL
CO3	FC, CSOL
CO11	FC, CFOL
CO13	FC, CFOL
HT1	HSOL
HT2	HSOL
HT3	HSOL
HT11	HFOL
HT12	HFOL
HT13	HFOL
CT1	CSOL
CT2	CSOL
CT3	CSOL
CT11	CFOL
CT12	CFOL
CT13	CFOL
0	TB OLC
0A	D, U, MC
0B	TB MC
0C	TB HSOL
0D	HSOL, HFOL
0E	HFOL, OLC, MC
0H	OLC, D, BCM
1	TB
1A	U, D, MC
1H	TB U, BCM
2	TB TDR
2A	TB TDR, F, MC
19	TB OLC
40	TB
40A	L, R
40B	TB CSOL
40C	CSOL, CFOL
40D	CFOL, L
41	TB
41A	R, L
42	TB FC
H91	PPD, BCM, MC
H91A	HCFU, PPD
92	TB HCPT, OLC, U, D, F, BCM, MC, R, L, FC
CB1	TB R-L
CB2	TB R-L
HB1	BCM
HB2	BCM



DANGER:

(PPD) - PHASE REVERSAL/LOSS PROTECTION DEVICE SHOWS A STEADY AMBER LED WHEN IN PHASE REVERSAL CONDITION. CORRECT IMPROPER PHASING BY INTER-CHANGING INPUT POWER LEADS L1 AND L2. DO NOT CHANGE PUSHBUTTON OR MOTOR CIRCUIT WIRING.

WARNING:

THIS EQUIPMENT MUST BE EFFECTIVELY GROUNDED ACCORDING TO APPLICABLE CODES.

AVERTISSEMENT:

CET EQUIPEMENT DOIT ETRE MIS A LA TERRE EN ACCORDANCE AVEC LES NORMES EN VIGUEUR.

PPD - PHASE REV./LOSS PROTECTION DEVICE

- HFU - HOIST MOTOR CIRCUIT FUSING
- PFU - TRANSFORMER PRIMARY FUSING
- HCPT - CONTROL CIRCUIT TRANSFORMER
- HCFU - CONTROL CIRCUIT FUSING
- U - HOIST UP CONTACTOR
- D - HOIST DOWN CONTACTOR
- F - HOIST FAST SPEED CONTACTOR
- HSOL - HOIST SLOW SPEED THERMAL OVERLOAD RELAY
- HFOL - HOIST FAST SPEED THERMAL OVERLOAD RELAY
- LSU - HOIST UPPER GEAR TYPE LIMIT SWITCH
- LSD - HOIST LOWER GEAR TYPE LIMIT SWITCH
- BCM - D.C. BRAKE CONTROL MODULE
- TDR - TIMER DELAY MODULE
- HTAS - HOIST MOTOR TEMPERATURE ACTUATED SWITCH
- OLS - OVERLOAD LIMIT SWITCH
- OLC - OVERLOAD LIMIT SWITCH CONTACTOR

SYMBOL DESIGNATIONS

- CFU - TROLLEY MOTOR CIRCUIT FUSING
- R - TROLLEY RIGHT CONTACTOR
- L - TROLLEY LEFT CONTACTOR
- FC - TROLLEY FAST SPEED CONTACTOR
- CSOL - TROLLEY SLOW SPEED THERMAL OVERLOAD RELAY
- CFOL - TROLLEY FAST SPEED THERMAL OVERLOAD RELAY
- CTAS - TROLLEY MOTOR TEMPERATURE ACTIVATED SWITCH
- MC - MONITOR CARD
- TB - TERMINAL BOARD
- G - FRAME GROUND

SECTION IX - PARTS LIST

9-1. GENERAL

The parts lists and illustrations in this section of the manual cover parts for models of YALE "Global King" Electric hoists. A typical hoist is shown as the basis for the exploded parts illustrations; therefore, certain variations may occur from the information given. For this reason, always give the Hoist Serial Number, Catalog Number, Motor Horsepower, Voltage, Phase, Frequency and Capacity of Hoist when ordering parts.

Yale "Global King" hoists are built in three basic frame sizes, "B", "C" and "D" Frame. To determine the size of your hoist, measure the width of hoist gearcase (see Figure 4-2). The "B" Frame measures 9-3/4" wide and requires approximately 5 quarts of oil. The "C" Frame measures 12-1/2" and requires approximately 11 quarts of oil. The "D" Frame measures 17" and requires approximately 12 quarts of oil..

Certain parts of your hoist will, in time, require replacement under normal wear conditions. It is suggested that these parts be purchased for your hoist as spares for future use. These parts are listed at the end of this manual.

The numbers assigned to parts of our various assemblies in our Parts List are the part numbers used in manufacturing. Some of these itemized parts are not for individual sale, but must be grouped with other related replacement items.

WHEN ORDERING PARTS OR INFORMATION ON THIS EQUIPMENT, ALWAYS INCLUDE MODEL AND SERIAL NUMBER ON ORDER.

WARNING

Using "Commercial" or other manufacturer's parts to repair Global King Hoists may cause load loss.

TO AVOID INJURY:

Use only YALE Hoist supplied parts. Parts may look alike but YALE Hoist parts are made of specific materials or processed to achieve specific properties.

**PARTS
STAR** 
BY COLUMBUS MCKINNON

LIST OF PART ILLUSTRATIONS

TITLE	FIGURE No.	PAGE No.
Hoist Drum, Drum Frame, Gearcase, Motor, Rope Guide, and Limit Switch	9-1a,9-1b	30-35
Hoist Gearing	9-2	36-38
Motor Driven Trolley Frame and Drive	9-3a, 9-3b, 9-3c, 9-3d	39-43
Lower Block Assembly	9-4a, 9-4b	44-46
Upper Block Assembly	9-5a, 9-5b	47-49
Wire Rope Dead End Assembly with Limit Switch	9-6a, 9-6b	50-52
Rope Guide Assembly	9-7a, 9-7b, 9-7c	53-55
Hoist Motor Brake – Standard Service (ABM Motor)	9-8a, 9-8b	56-57
Hoist Motor Brake – Outdoor Service (ABM Motor)	9-9a, 9-9b	58-59
Hoist Motor Brake – Standard Service (MGM Motor)	9-10a, 9-10b	60
Hoist Motor Brake – Outdoor Service (MGM Motor)	9-11a, 9-11b	61

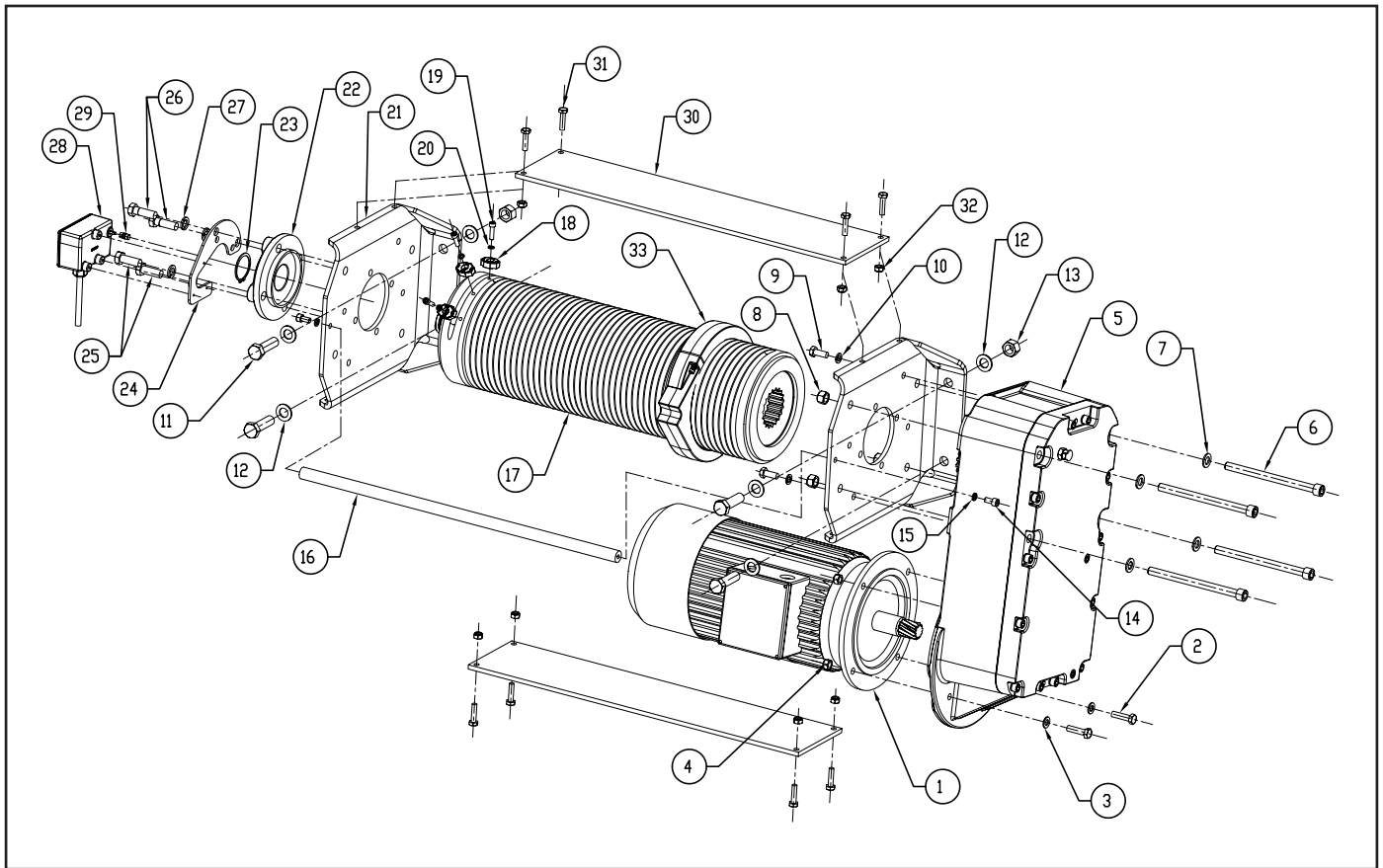

Figure 9-1a. Hoist Drum, Drum Frame, Gearcase, Motor, Rope Guide and Screw Type Limit Switch

“B” Frame: Hoist Components for Figure 9-1a.

REF. No.	Part Number	Description	Qty. Req'd
1	See Chart	7.5 HP Hoist Motor, 2-Speed with Brake and Fan	1
2	N/A	Hex Head Bolt, M12	2
3	N/A	Flat Washer, M12	2
4	N/A	Locknut, M12	4
5	44933001	Hoist Gearcase (See Figure 9-2 for Parts) 1	
6	N/A	Socket Head Cap Screw, M12	4
7	N/A	Flat Washer, M12	4
8	N/A	Locknut, M12	4
9	N/A	Hex Head Bolt, M12	2
10	N/A	Lockwasher, M12	2
11	N/A	Hex Head Bolt, M16	4
12	N/A	High Strength Flat Washer, M16	8
13	N/A	Locknut, M16	4
14	N/A	Socket Head Cap Screw, M10	2
15	N/A	Hi-Collar Lockwasher, M10	2
16	-	Drum Frame Rod	1
	23385901	Frame Rod, 25' Lift Model	
	23385902	Frame Rod, 40' Lift Model	
	23385906	Frame Rod, 60' Lift Model	
17	-	Rope Drum	1
	44931501	Rope Drum, 25' Lift Model	
	44931502	Rope Drum, 40' Lift Model	
	44931503	Rope Drum, 60' Lift Model	

(continued on next page)

“B” Frame: Hoist Components for Figure 9-1a.

REF. No.	Part Number	Description	Qty. Req'd
18	23380301	Rope Clamp	3
19	N/A	Socket Head Cap Screw, M8	3
20	N/A	Hi-Collar Lockwasher, M8	3
21	33291102	Drum Frame Bracket	2
22	11801803	Flanged Cartridge Ball Bearing	1
23	11802401	Heavy Duty External Retaining Ring	1
24	23383801	Limit Switch Bracket	1
25	N/A	Hex Head Bolt (Short), M12	2
26	N/A	Hex Head Bolt (Long), M12	2
27	N/A	Lockwasher, M12	4
28	43981305	Geared Limit Switch	1
29	11593901	Drum Shaft Insert for Geared Limit Switch	1
30	-	Stiffener Plate	2
	N/A	Stiffener Plate, 25' Lift Model	
	N/A	Stiffener Plate, 40' Lift Model	
	N/A	Stiffener Plate, 60' Lift Model	
31	N/A	Socket Head Cap Screw, M10	8
32	N/A	Locknut, M10	8
33	44931801C	Rope Guide (See Figure 9-7a for Parts)	1
34	NO12283	Hydraulic Fitting for Flanged Cartridge Ball Bearing (Not Shown)	1
35a	44930801	SHAW-BOX Brand Label for Gearcase (Not Shown)	1
35b	44930802	Yale Brand Label for Gearcase (Not Shown)	1

“C” Frame: Hoist Components for Figure 9-1a.

REF. No.	Part Number	Description	Qty. Req'd
1	See Chart	7.5 HP Hoist Motor, 2-Speed with Brake and Fan	1
2	N/A	Hex Head Bolt, M12	2
3	N/A	Flat Washer, M12	2
4	N/A	Locknut, M12	4
5	44935501	Hoist Gearcase (See Figure 9-2 for Parts) 1	
6	N/A	Socket Head Cap Screw, M12	4
7	N/A	Flat Washer, M12	4
8	N/A	Locknut, M12	4
9	N/A	Hex Head Bolt, M12	2
10	N/A	Lockwasher, M12	2
11	N/A	Hex Head Bolt, M16	4
12	N/A	High Strength Flat Washer, M16	8
13	N/A	Locknut, M16	4
14	N/A	Socket Head Cap Screw, M10	2
15	N/A	Hi-Collar Lockwasher, M10	2
16	-	Drum Frame Rod	1
	23387601	Frame Rod, 25' Lift Model	
	23387602	Frame Rod, 40' Lift Model	
	23387605	Frame Rod, 60' Lift Model	
17	-	Rope Drum	1
	44933501	Rope Drum, 25' Lift Model	
	44933502	Rope Drum, 40' Lift Model	
	44933503	Rope Drum, 60' Lift Model	

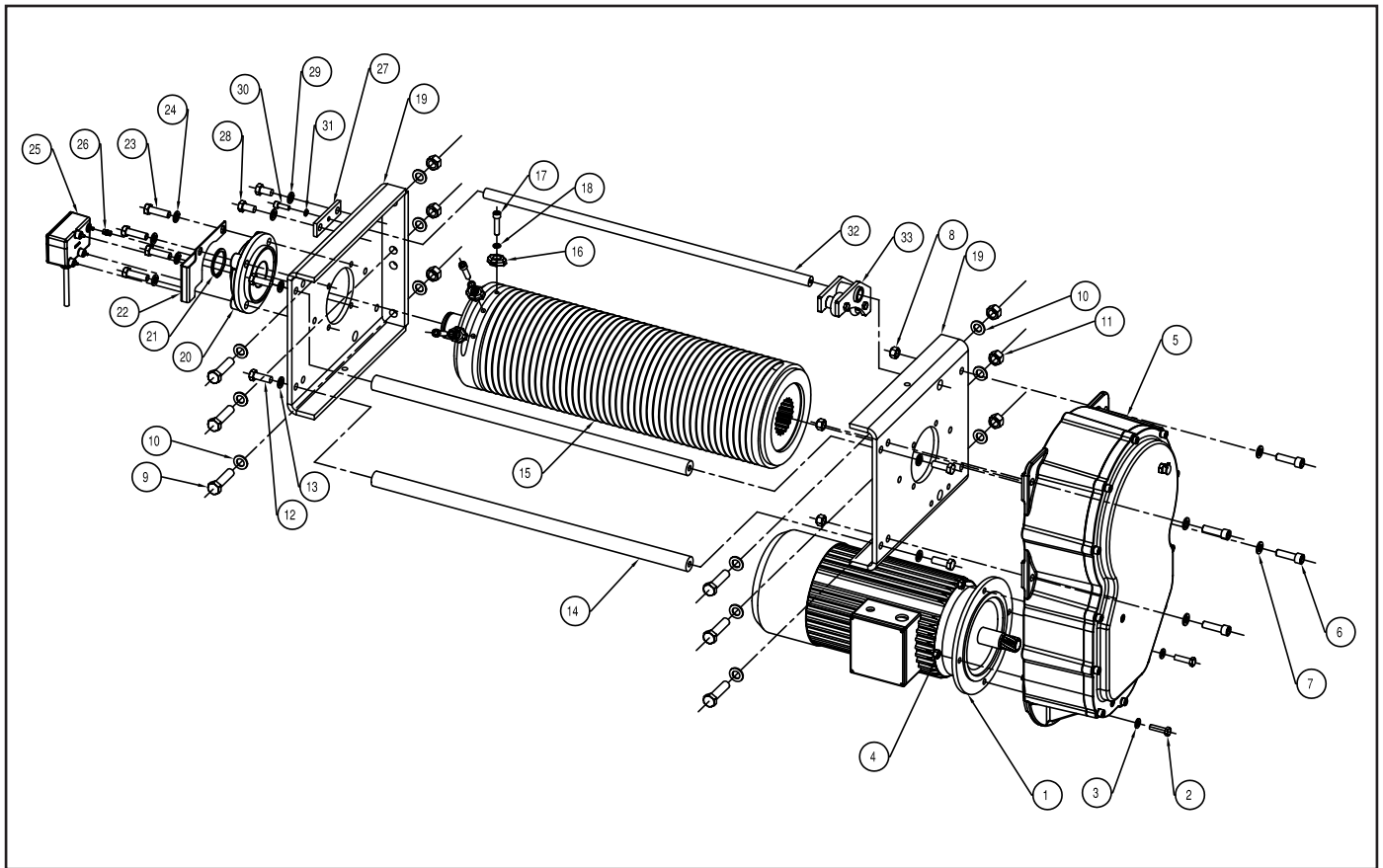

Figure 9-1b. Hoist Drum, Drum Frame, Gearcase, Motor, Rope Guide and Screw Type Limit Switch

“D” Frame: Hoist Components for Figure 9-1b.

REF. No.	Part Number	Description	Qty. Req'd
1	See Chart	2 0 HP Hoist Motor, 2-Speed with Brake and Fan (See Figure 9-8 for Parts) 1	
2	N/A	Hex Head Bolt, M12	2
3	N/A	Flat Washer, M12	2
4	N/A	Locknut, M12	4
5	44936501	Hoist Gearcase (See Figure 9-2 for Parts)	1
6	N/A	Socket Head Cap Screw, M16	4
7	N/A	Flat Washer, M16	4
8	N/A	Locknut, M16	4
9	N/A	Hex Head Bolt, M20	6
10	N/A	High Strength Flat Washer, M20	12
11	N/A	Locknut, M20	6
12	N/A	Hex Head Bolt, M16	4
13	N/A	Lockwasher, M16	4
14	-	Drum Frame Rod	2
	23394601	Frame Rod, 25' Lift Model	
	23394602	Frame Rod, 40' Lift Model	
	23394603	Frame Rod, 60' Lift Model	
15	-	Rope Drum	1
	44936701	Rope Drum, 25' Lift Model	
	44936702	Rope Drum, 40' Lift Model	
	44936703	Rope Drum, 60' Lift Model	
16	23332702	Rope Clamp	3
17	N/A	Socket Head Cap Screw, M12	3

(continued on next page)

“D” Frame: Hoist Components for Figure 9-1b.

REF. No.	Part Number	Description	Qty. Req'd
18	N/A	Hi-Collar Lockwasher, M12	3
19	33293301	Drum Frame Bracket	2
20	11801804	Flanged Cartridge Ball Bearing	1
21	11802402	Heavy Duty External Retaining Ring	1
22	2 3395201	Limit Switch Bracket	1
23	N/A	Hex Head Bolt, M16	4
24	N/A	Lockwasher, M16	4
25	43981305	Geared Limit Switch	1
26	11593901	Drum Shaft Insert for Geared Limit Switch	1
27	N/A	Rope Guide Keeper Plate	1
28	N/A	Hex Head Bolt, M16	2
29	N/A	Lockwasher, M16	2
30	N/A	Socket Head Cap Screw, M10	1
31	N/A	Hi-Collar Lockwasher, M10	1
32	-	Rope Guide Rod	1
	23387603	Guide Rod, 25' Lift Model	
	23387604	Guide Rod, 40' Lift Model	
33	33293401C	Rope Guide (See Figure 9-7b for Parts)	1
34a	44937201	Yale Brand Label for Gearcase (Not Shown)	1
34b	44937202	Yale Brand Label for Gearcase (Not Shown)	1

2-SPEED ABM HOIST MOTORS

MOTOR 7.5/1.875 HP 3600/900 RPM	B FRAME 5 TONNE	MOTOR 15/3.75 HP 3600/900 RPM	C FRAME 7-1/2 & 10 TONNE	MOTOR 20/5 HP 3600/900 RPM	D FRAME 15 TONNE
POWER SUPPLY	PART NUMBER	POWER SUPPLY	PART NUMBER	POWER SUPPLY	PART NUMBER
208V-3PH-60HZ	33313801	208V-3PH-60HZ	33314001	208V-3PH-60HZ	33292901
230V-3PH-60HZ	33313802	230V-3PH-60HZ	33314002	230V-3PH-60HZ	33292902
460V-3PH-60HZ	33313803	460V-3PH-60HZ	33314003	460V-3PH-60HZ	33292903
575V-3PH-60HZ	33313804	575V-3PH-60HZ	33314004	575V-3PH-60HZ	33292904
380V-3PH-50HZ	33313805	380V-3PH-50HZ	33314005	380V-3PH-50HZ	33292905

2-SPEED ABM HOIST MOTORS WITH IP55 MOTOR BRAKE (OUTDOOR SERVICE)

MOTOR 7.5/1.875 HP 3600/900 RPM	B FRAME 5 TONNE	MOTOR 15/3.75 HP 3600/900 RPM	C FRAME 7-1/2 & 10 TONNE	MOTOR 20/5 HP 3600/900 RPM	D FRAME 15 TONNE
POWER SUPPLY	PART NUMBER	POWER SUPPLY	PART NUMBER	POWER SUPPLY	PART NUMBER
208V-3PH-60HZ	33294001	208V-3PH-60HZ	33294101	208V-3PH-60HZ	33294201
230V-3PH-60HZ	33294002	230V-3PH-60HZ	33294102	230V-3PH-60HZ	33294202
460V-3PH-60HZ	33294003	460V-3PH-60HZ	33294103	460V-3PH-60HZ	33294203
575V-3PH-60HZ	33294004	575V-3PH-60HZ	33294104	575V-3PH-60HZ	33294204
380V-3PH-50HZ	33294005	380V-3PH-50HZ	33294105	380V-3PH-50HZ	33294205

2-SPEED MGM HOIST MOTORS

MOTOR 7.5/1.875 HP 3600/900 RPM	B FRAME 5 TONNE	MOTOR 15/3.75 HP 3600/900 RPM	C FRAME 7-1/2 & 10 TONNE	MOTOR 20/5 HP 3600/900 RPM	D FRAME 15 TONNE
POWER SUPPLY	PART NUMBER	POWER SUPPLY	PART NUMBER	POWER SUPPLY	PART NUMBER
208V-3PH-60HZ	33327301	208V-3PH-60HZ	33330701	208V-3PH-60HZ	33330801
230V-3PH-60HZ	33327302	230V-3PH-60HZ	33330702	230V-3PH-60HZ	33330802
460V-3PH-60HZ*	33327303	460V-3PH-60HZ	33330703	460V-3PH-60HZ	33330803
575V-3PH-60HZ	33327304	575V-3PH-60HZ	33330704	575V-3PH-60HZ	33330804
380V-3PH-50HZ*	33327303	380V-3PH-50HZ	33330703	380V-3PH-50HZ	33330803

2-SPEED MGM HOIST MOTORS WITH IP55 MOTOR BRAKE (OUTDOOR SERVICE)

MOTOR 7.5/1.875 HP 3600/900 RPM	B FRAME 5 TONNE	MOTOR 15/3.75 HP 3600/900 RPM	C FRAME 7-1/2 & 10 TONNE	MOTOR 20/5 HP 3600/900 RPM	D FRAME 15 TONNE
POWER SUPPLY	PART NUMBER	POWER SUPPLY	PART NUMBER	POWER SUPPLY	PART NUMBER
208V-3PH-60HZ	33327311	208V-3PH-60HZ	33330711	208V-3PH-60HZ	33330811
230V-3PH-60HZ	33327312	230V-3PH-60HZ	33330712	230V-3PH-60HZ	33330812
460V-3PH-60HZ*	33327313	460V-3PH-60HZ	33330713	460V-3PH-60HZ	33330813
575V-3PH-60HZ	33327314	575V-3PH-60HZ	33330714	575V-3PH-60HZ	33330814
380V-3PH-50HZ*	33327313	380V-3PH-50HZ	33330713	380V-3PH-50HZ	33330813

*Note: Motors are dual rated for 460V-3PH-60HZ and 380V-3PH-50HZ power supply.

INVERTER DUTY MGM HOIST MOTORS

MOTOR 4.8 HP 1800 RPM	B FRAME 5 TONNE	MOTOR 8.8 HP 1800 RPM	C FRAME 7-1/2 & 10 TONNE	MOTOR 12 HP 1800 RPM	D FRAME 15 TONNE
POWER SUPPLY	PART NUMBER	POWER SUPPLY	PART NUMBER	POWER SUPPLY	PART NUMBER
208V-3PH-60HZ	33336601	208V-3PH-60HZ	33336602	208V-3PH-60HZ	33336603
230V-3PH-60HZ		230V-3PH-60HZ		230V-3PH-60HZ	
460V-3PH-60HZ		460V-3PH-60HZ		460V-3PH-60HZ	
575V-3PH-60HZ	CONTACT FACTORY	575V-3PH-60HZ	CONTACT FACTORY	575V-3PH-60HZ	CONTACT FACTORY

INVERTER DUTY MGM HOIST MOTORS WITH IP55 MOTOR BRAKE (OUTDOOR SERVICE)

MOTOR 4.8 HP 1800 RPM	B FRAME 5 TONNE	MOTOR 8.8 HP 1800 RPM	C FRAME 7-1/2 & 10 TONNE	MOTOR 12 HP 1800 RPM	D FRAME 15 TONNE
POWER SUPPLY	PART NUMBER	POWER SUPPLY	PART NUMBER	POWER SUPPLY	PART NUMBER
208V-3PH-60HZ	33336611	208V-3PH-60HZ	33336612	208V-3PH-60HZ	33336613
230V-3PH-60HZ		230V-3PH-60HZ		230V-3PH-60HZ	
460V-3PH-60HZ		460V-3PH-60HZ		460V-3PH-60HZ	
575V-3PH-60HZ	CONTACT FACTORY	575V-3PH-60HZ	CONTACT FACTORY	575V-3PH-60HZ	CONTACT FACTORY

HOIST DYNAMIC BRAKING RESISTORS

MOTOR 4.8 HP 1800 RPM	B FRAME 5 TONNE	MOTOR 8.8 HP 1800 RPM	C FRAME 7-1/2 & 10 TONNE	MOTOR 12 HP 1800 RPM	D FRAME 15 TONNE
POWER SUPPLY	PART NUMBER	POWER SUPPLY	PART NUMBER	POWER SUPPLY	PART NUMBER
208V-3PH-60HZ	208V-3PH-60HZ	45430471	45430472	208V-3PH-60HZ	45430473
230V-3PH-60HZ	230V-3PH-60HZ			230V-3PH-60HZ	
460V-3PH-60HZ	460V-3PH-60HZ	45430474	45430475	460V-3PH-60HZ	45430476
575V-3PH-60HZ	575V-3PH-60HZ			575V-3PH-60HZ	

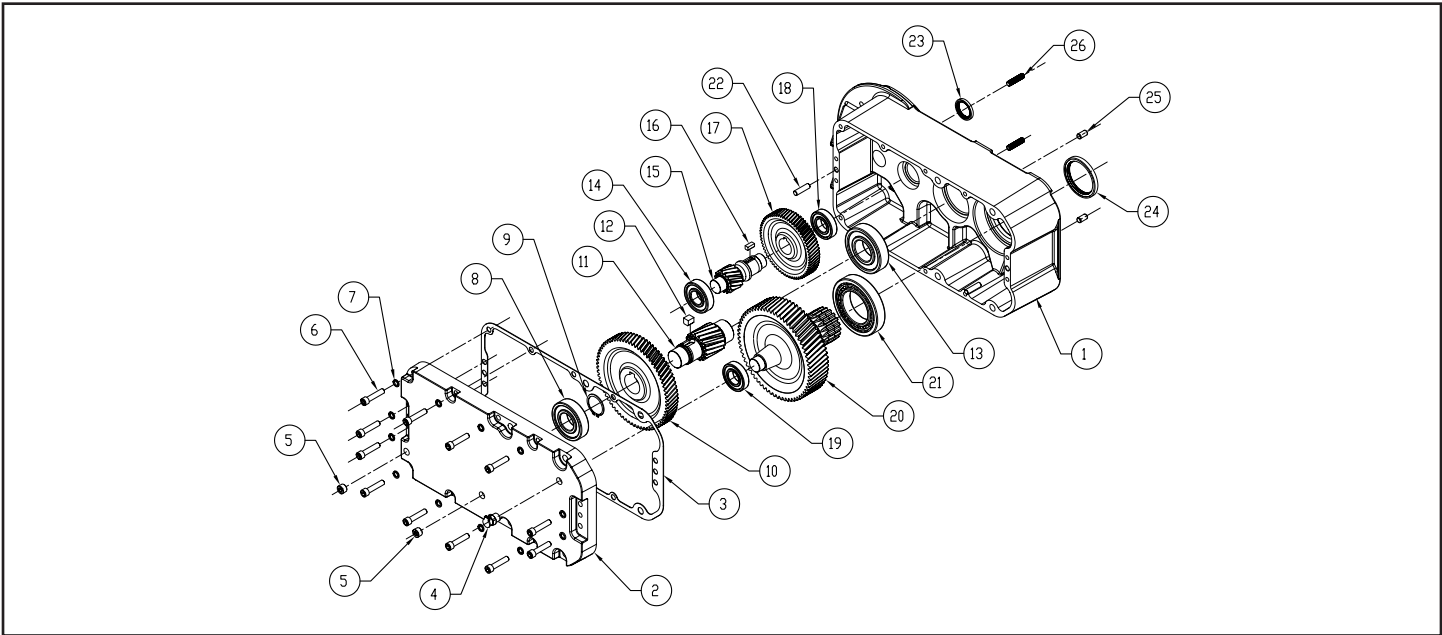

Figure 9-2. Hoist Gearing

“B” Frame: Hoist Gearing for Figure 9-2.			
REF. No.	Part Number	Description	Qty. Req'd
	4493300	C Complete 5t Hoist Gearcase Ass'y. - 80.57:1 Ratio	1
	44933090	Gearcase Gasket/Seal Kit (Incl. Ref. Nos. 3, 23, 24)	
	44933091	Gearcase Gasket/Bearings Kit (Incl. Ref. Nos. 3, 8, 13, 14, 18, 19, 21, 23, 24)	
1	N/A	Gearcase	1
2	N/A	Cover	1
3	N/A	Gasket	1
4	-	Vent Plug	1
5	-	Drain/Fill Level Plug	2
6	N/A	Socket Head Cap Screw, M8	12
7	N/A	Hi-Collar Lockwasher, M8	12
8	N/A	Ball Bearing	1
9	N/A	External Retaining Ring	1
10	N/A	Intermediate Gear	1
11	N/A	Drum Pinion Shaft	1
12	N/A	Key	1
13	N/A	Ball Bearing	1
14	N/A	Ball Bearing	1
15	N/A	Intermediate Pinion Shaft	1
16	N/A	Key	1
17	N/A	Motor Gear	1
18	N/A	Ball Bearing	1
19	N/A	Ball Bearing	1
20	N/A	Output Shaft	1
21	N/A	Roller Bearing	1
22	N/A	Dowel Pin	2
23	N/A	Motor Shaft Oil Seal	1
24	N/A	Output Shaft Oil Seal	1
25	N/A	Torque Pin	2
26	N/A	Threaded Stud, M12	2

"C" Frame: Hoist Gearing for Figure 9-2.

REF. No.	Part Number	Description	Qty. Req'd
	44935501C	Complete 10t Hoist Gearcase Ass'y. - 103.8:1 Ratio	1
	44935501C	Complete 7.5t Hoist Gearcase Ass'y. - 103.8:1 Ratio	
	44935590	Gearcase Gasket/Seal Kit (Incl. Ref. Nos. 3, 23, 24)	
	44935591	Gearcase Gasket/Bearings Kit (Incl. Ref. Nos. 3, 8, 13, 14, 18, 19, 21, 23, 24)	
1	N/A	Gearcase	1
2	N/A	Cover	1
3	N/A	Gasket	1
4	-	Vent Plug	1
5	-	Drain/Fill Level Plug	2
6	N/A	Socket Head Cap Screw, M12	12
7	N/A	Hi-Collar Lockwasher, M12	12
8	N/A	Ball Bearing	1
9	N/A	External Retaining Ring	1
10	N/A	Intermediate Gear	1
11	N/A	Drum Pinion Shaft	1
12	N/A	Key	1
13	N/A	Ball Bearing	1
14	N/A	Ball Bearing	1
15	N/A	Intermediate Pinion Shaft	1
16	N/A	Key	1
17	N/A	Motor Gear	1
18	N/A	Ball Bearing	1
19	N/A	Ball Bearing	1
20	N/A	Output Shaft	1
21	N/A	Roller Bearing	1
22	N/A	Dowel Pin	2
23	N/A	Motor Shaft Oil Seal	1
24	N/A	Output Shaft Oil Seal	1
25	N/A	Torque Pin	2
26	N/A	Threaded Stud, M12	2

NOTES

“D” Frame: Hoist Gearing for Figure 9-2.

REF. No.	Part Number	Description	Qty. Req'd
	44936501C	Complete 15t Hoist Gearcase Ass'y. - 132.7:1 Ratio	1
	44936590	Gearcase Gasket/Seal Kit (Incl. Ref. Nos. 3, 23, 24)	
	44936591	Gearcase Gasket/Bearings Kit (Incl. Ref. Nos. 3, 8, 13, 14, 18, 19, 21, 23, 24)	
1	N/A	Gearcase	1
2	N/A	Cover	1
3	N/A	Gasket	1
4	N/A	Vent Plug	1
5	N/A	Drain/Fill Level Plug	1
6a	N/A	Socket Head Cap Screw, M12	10
6b	N/A	Socket Head Shoulder Screw, M12 (not shown)	2
7	N/A	Hi-Collar Lockwasher, M12	12
8	N/A	Ball Bearing	1
9	N/A	External Retaining Ring	1
10	N/A	Intermediate Gear	1
11	N/A	Drum Pinion Shaft	1
12	N/A	Key	1
13	N/A	Ball Bearing	1
14	N/A	Ball Bearing	1
15	N/A	Intermediate Pinion Shaft	1
16	N/A	Key	1
17	N/A	Motor Gear	1
18	N/A	Ball Bearing	1
19	N/A	Ball Bearing	1
20	N/A	Output Shaft	1
21	N/A	Roller Bearing	1
22	N/A	Dowel Pin	2
23	N/A	Motor Shaft Oil Seal	1
24	N/A	Output Shaft Oil Seal	1
25	N/A	Torque Pin	2
26	N/A	Threaded Stud, M12	2

NOTES

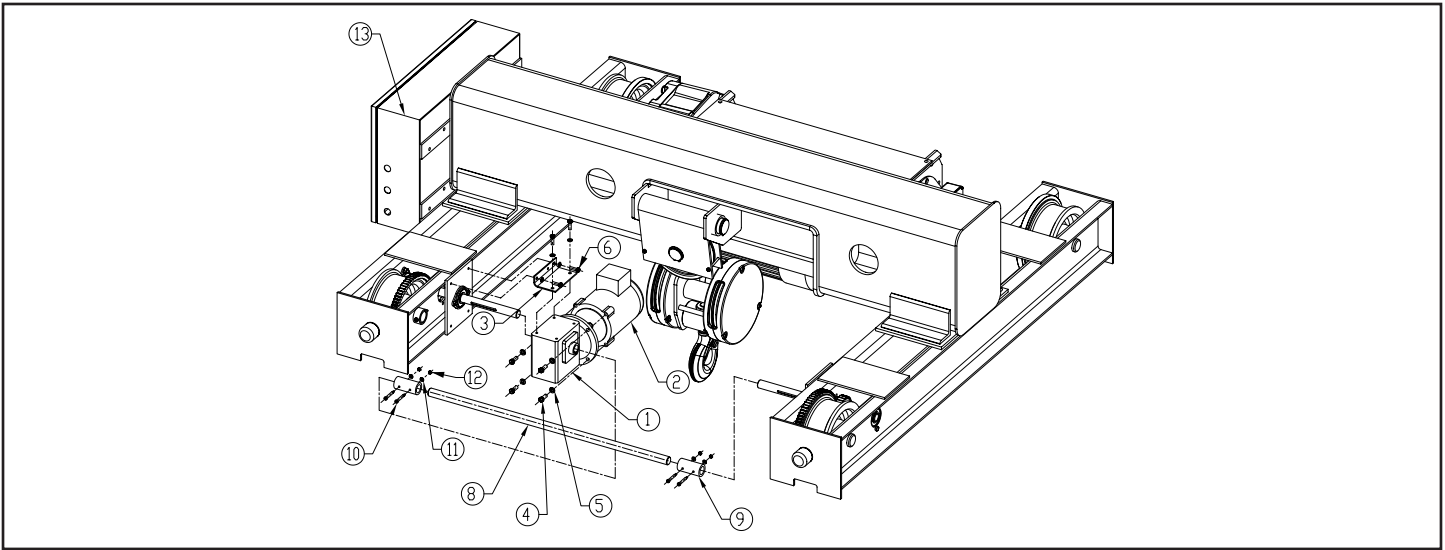

Figure 9-3a. Traverse Drive Component (“B” Frame Shown).

“B” Frame: Traverse Drive Components for Figure 9-3a.			
REF. No.	Part Number	Description	Qty. Req'd
1	-	Traverse Reducer	1
	905378	Traverse Reducer, 50 FPM	
	905377	Traverse Reducer, 70 FPM	
2	See Chart	Traverse Motor (Specify HP, Voltage, Frequency, No. of Speeds, Options)	1
3	22727701	Torque Arm	1
4	NO796	Hex Head Bolt, 3/8”-16	4
5	NO437	Lockwasher, 3/8”	4
6	10392029	Socket Head Cap Screw, 5/16”-18	4
7	NO661	Lockwasher, 5/16”	4
8	-	Cross Shaft (Specify Gauge)	1
9	11556601	Rigid Coupling	2
10	11567707	Socket Head Shoulder Bolt, #10 Thread	4
11	10402712	Flat Washer, #10	4
12	10024807	Locknut, #10	4
13	-	Hoist/Trolley Controls (Specify HP, Voltage, Frequency, No. of Speeds, Options)	1

“B” Frame: Traverse Drive Components for Figure 9-3a.			
REF. No.	Part Number	Description	Qty. Req'd
1	-	Traverse Reducer	1
	905378	Traverse Reducer, 50 FPM	
	905377	Traverse Reducer, 70 FPM	
2	See Chart	Traverse Motor (Specify HP, Voltage, Frequency, No. of Speeds, Options)	1
3	22727701	Torque Arm	1
4	NO796	Hex Head Bolt, 3/8”-16	4
5	NO437	Lockwasher, 3/8”	4
6	10392029	Socket Head Cap Screw, 5/16”-18	4
7	NO661	Lockwasher, 5/16”	4
8	N/A	Component Not Required	0
9	N/A	Component Not Required	0
10	N/A	Component Not Required	0
11	N/A	Component Not Required	0
12	N/A	Component Not Required	0
13	-	Hoist/Trolley Controls (Specify HP, Voltage, Frequency, No. of Speeds, Options)	1

1-SPEED TROLLEY MOTORS †

MOTOR .5/17 HP 1800/600 RPM	B FRAME 5 TONNE (S4 REEVING) 2-1/2 TONNE (S2 REEVING)	MOTOR .75/.25 HP 1800/600 RPM	C FRAME 7-1/2 & 10 TONNE (S4 REEVING) 3-3/4 & 5 TONNE (S2 REEVING)	MOTOR 1/.33 HP 1800/600 RPM	D FRAME WITHOUT BRAKE*	MOTOR 1/.33 HP 1800/600 RPM	D FRAME WITH BRAKE*
POWER SUPPLY	PART NUMBER	POWER SUPPLY	PART NUMBER	POWER SUPPLY	PART NUMBER	POWER SUPPLY	PART NUMBER
208V-3PH-60HZ	32879532	208V-3PH-60HZ	32879542	208V-3PH-60HZ	32879552	208V-3PH-60HZ	33198102
230V-3PH-60HZ	32879532	230V-3PH-60HZ	32879542	230V-3PH-60HZ	32879552	230V-3PH-60HZ	33198103
460V-3PH-60HZ	32879532	460V-3PH-60HZ	32879542	460V-3PH-60HZ	32879552	460V-3PH-60HZ	33198103
575V-3PH-60HZ	32879533	575V-3PH-60HZ	32879543	575V-3PH-60HZ	32879553	575V-3PH-60HZ	33198104
380V-3PH-50HZ	32879532	380V-3PH-50HZ	32879542	380V-3PH-50HZ	32879552	380V-3PH-50HZ	11705272

MOTOR .75/.25 HP 1800/600 RPM	B FRAME 5 TONNE (S4 REEVING) 2-1/2 TONNE (S2 REEVING)	MOTOR 1/.33 HP 1800/600 RPM	C FRAME 7-1/2 & 10 TONNE (S4 REEVING) 3-3/4 & 5 TONNE (S2 REEVING)	MOTOR 1.5/.5 HP 1800/600 RPM	D FRAME WITHOUT BRAKE*	MOTOR 1.5/.5 HP 1800/600 RPM	D FRAME WITH BRAKE*
POWER SUPPLY	PART NUMBER	POWER SUPPLY	PART NUMBER	POWER SUPPLY	PART NUMBER	POWER SUPPLY	PART NUMBER
208V-3PH-60HZ	32879542	208V-3PH-60HZ	32879552	208V-3PH-60HZ	32879590	208V-3PH-60HZ	33198107
230V-3PH-60HZ	32879542	230V-3PH-60HZ	32879552	230V-3PH-60HZ	32879590	230V-3PH-60HZ	33198108
460V-3PH-60HZ	32879542	460V-3PH-60HZ	32879552	460V-3PH-60HZ	32879590	460V-3PH-60HZ	33198108
575V-3PH-60HZ	32879543	575V-3PH-60HZ	32879553	575V-3PH-60HZ	32879591	575V-3PH-60HZ	33198109
380V-3PH-50HZ	32879542	380V-3PH-50HZ	32879552	380V-3PH-50HZ	N/A	380V-3PH-50HZ	N/A

† Also furnished with trolley VFC

*Note: The D-frame model only uses a single shaft motor when furnished without brake and a double shaft motor when brake is included.

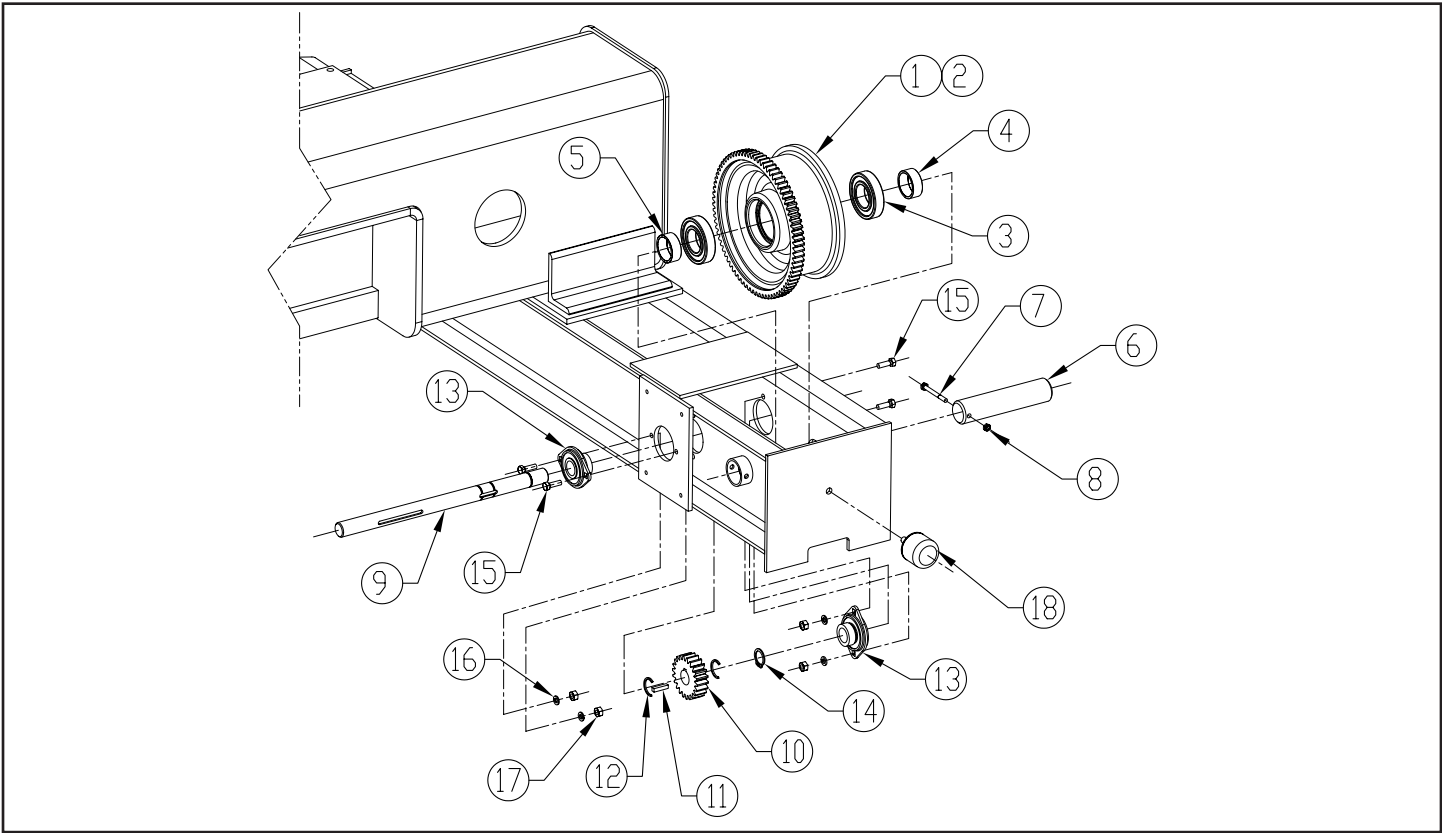

Figure 9-3b. Common Traverse Drive Component (“B” & “C” Frame)

Common Traverse Drive Components (“B” & “C” Frame) for Figure 9-3b.			
REF. No.	Part Number	Description	Qty. Req'd
1	32925301	Geared Trolley Wheel	2
2	32925302	Plain Trolley Wheel	2
3	905377	Ball Bearing	8
4	11572501	Bearing Retainer	4
5	11572502	Bearing Retainer	4
6	11572403	Wheel Axle	4
7	10853806	Hex Head Bolt, 1/4”	4
8	10024810	Locknut, 1/4”	4
9	22741701	Pinion Shaft	2
10	22741601	Pinion	2
11	10450712	Key	2
12	43963321	External Retaining Ring	4
13	43940516	Flange Bearing	4
14	10846007	Heavy Duty External Retaining Ring	2
15	NO3985	Hex Head Bolt, 5/16”	16
16	NO8526	Lockwasher, 5/16”	16
17	NO828	Hex Nut. 5/16”	16
18	11680701	Bumper	4

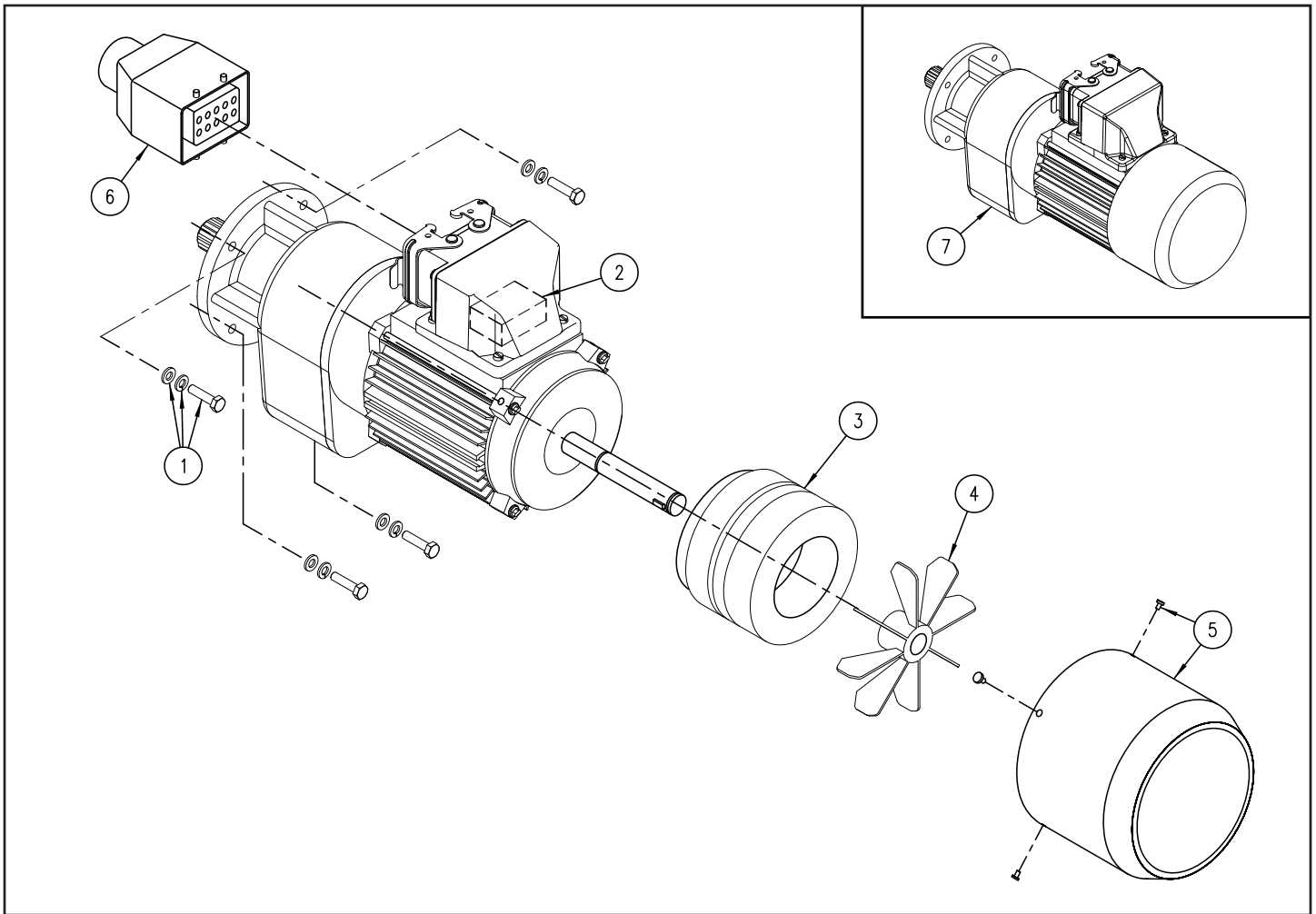
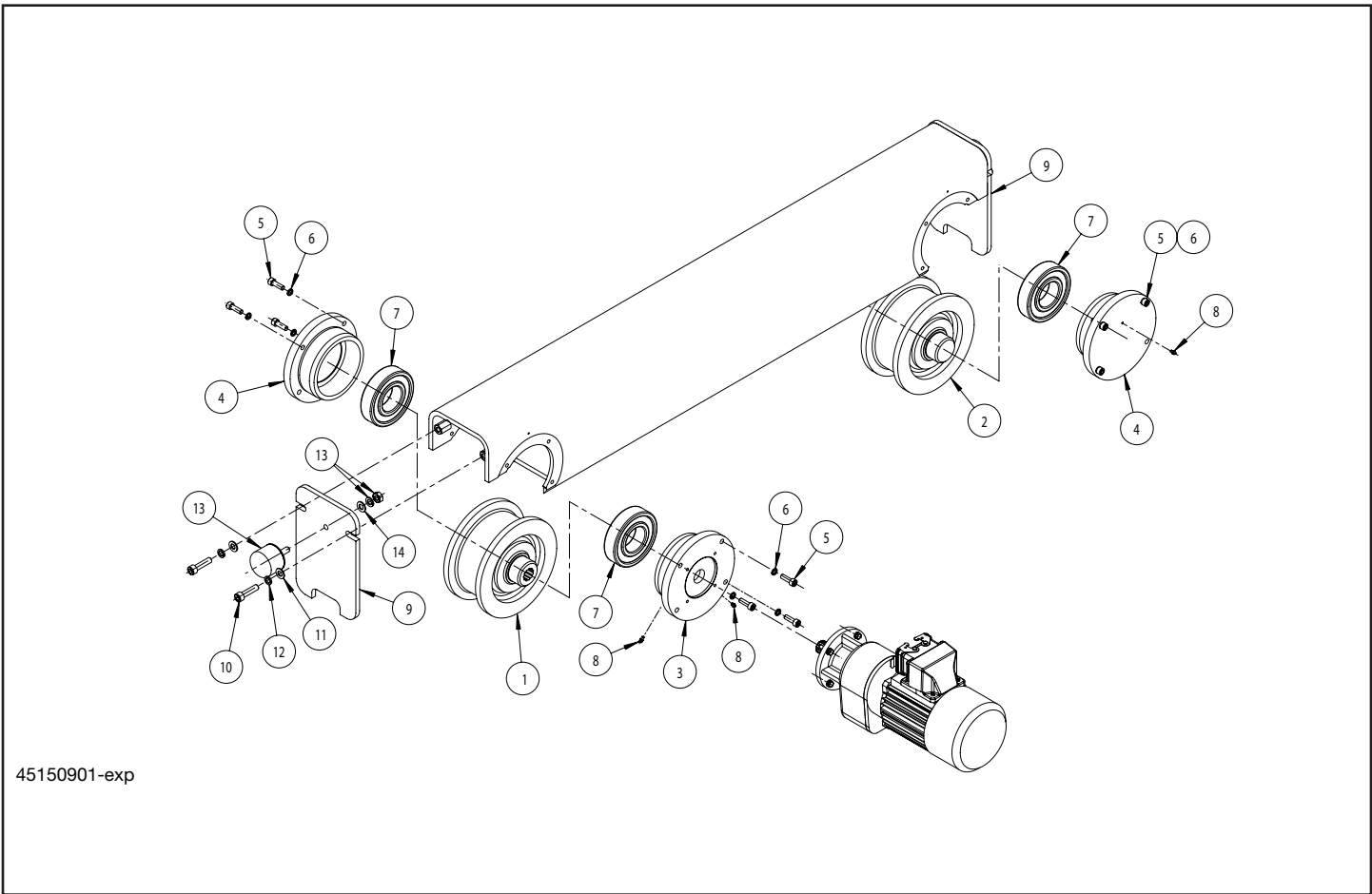

Figure 9-3c. Traverse Drive ("D" Frame)

"D" Frame: Traverse Drive Components (Pair) for Figure 9-3c.

REF. No.	Description	Qty. Req'd	"D" Frame: 15t 160 mm Truck (0.75 kW, 1 hp)	"D" Frame: 20t 200 mm Truck (1.2 kW, 1½ hp)
			Part Number	Part Number
1	Mounting Hardware Kit	2	45152051	45152052
2	Brake Rectifier, (380/460V & 575V)	2	45152065	
	Brake Rectifier, (190/200-230V)	2	45152066	
3	Complete Brake Kit 180VDC, (190/200-230V & 380/460V)	2	45152055	45152059
	Complete Brake Kit 250VDC, (575V)	2	45152056	45152060
4	Fan Kit (where applicable)	2	45152075	45152077
5	Shroud Kit	2	45152080	45152082
6	Mating Easy Connect Plug (where applicable)	2	11829301	
Complete Gearmotor Assembly				
7	190volt-3phase-50Hz, 208/230volt-3phase-60Hz	2	45152011	45152021
	380volt-3phase-50Hz, 460volt-3phase-60Hz		45152013	45152023
	575volt-3phase-60Hz		45152014	45152024



45150901-exp

Figure 9-3d. Common Traverse Drive Components ("D" Frame)

"D" Frame Traverse Drive Components (Pair) for Figure 9.3d

REF. No.	Description	15t (160 mm Truck)		20t (200 mm Truck)	
		Part No.	Qty.	Part No.	Qty.
1	Driver Wheel (65 mm tread)	23487601	2	23487701	2
	Driver Wheel (88 mm tread)	23487603	2	23487703	2
2	Trailer Wheel (65 mm tread)	23487602	2	23487702	2
	Trailer Wheel (88 mm tread)	23487604	2	23487704	2
3	Bearing Cage, Open (Driver)	23488001	2	23488101	2
4	Bearing Cage, Closed (Trailer)	23488002	6	23488102	6
5	SHCS	11802705	24	11802728	24
6	Hi-Collar Lock Washer	11803202	24	11803202	24
7	Bearing	10378016	8	10380106	8
8	Grease Fitting	-	-	NO6099	10
9	Rail Sweep (65 mm tread)	23488805	4	23488901	4
	Rail Sweep (88 mm tread)	23488806	4	23488902	4
10	M10-1.50 SHCS	11802729	8	11802729	8
11	M10 Flat Washer	11803101	8	11803101	8
12	M10 Hi-Collar Lock Washer	11803203	8	11803203	8
13	Bumper - R1	11680704	4	-	-
	Bumper - R2	-	-	11680701	4
14	Flat Washer- R1	11803102	4	-	-
	Flat Washer - R2	-	-	11803101	4

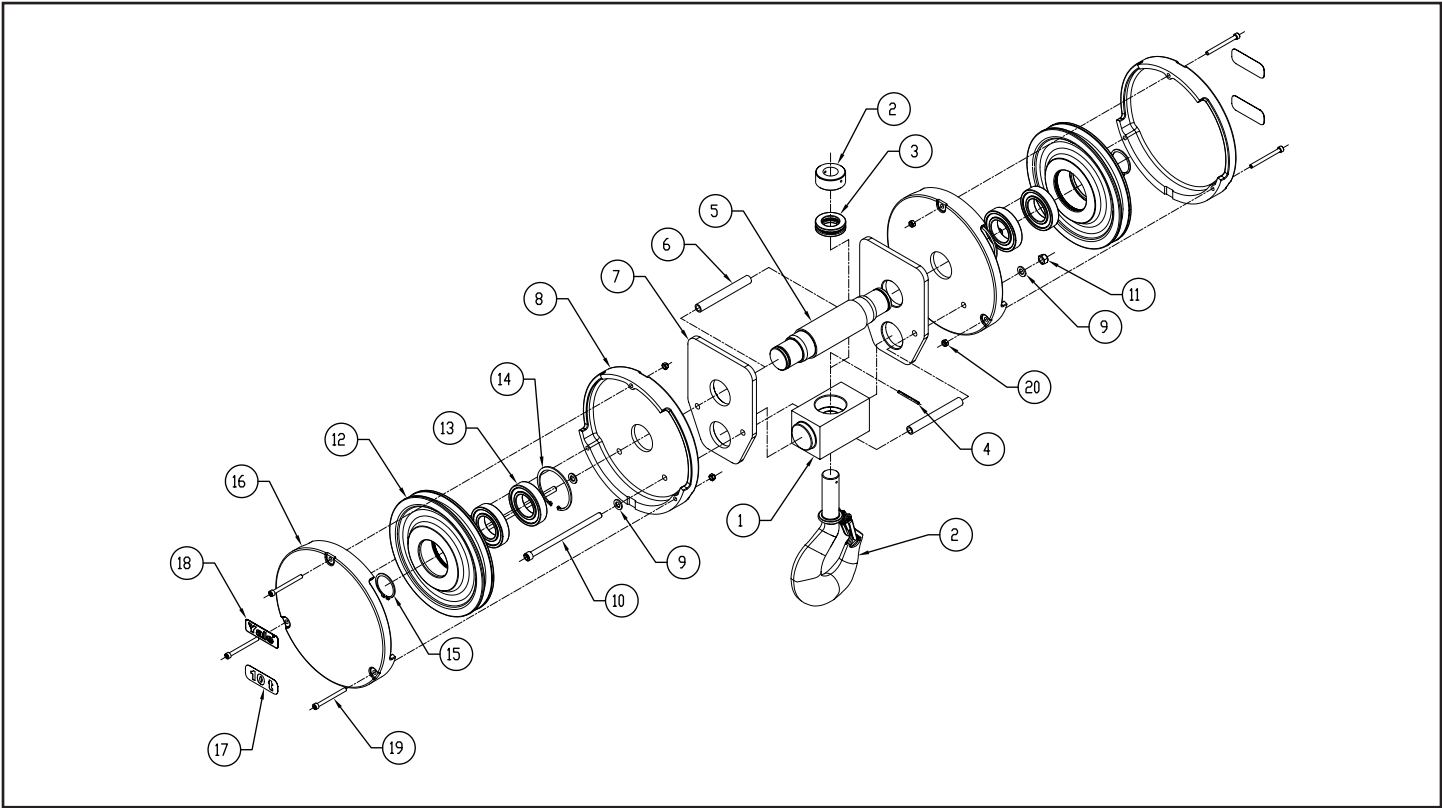

Figure 9-4a. Lower Block Assembly (4-Part Reeving)

“B” Frame: Lower Block Components for Figure 9-4a.

REF. No.	Part Number	Description	Qty. Req'd
	44931901C	Lower Block Assembly (Excludes Ref. Nos. 17 & 18)	1
	33290601	Sheave Assembly (Incl. Ref. Nos. 12, 13, 14)	
	4X1309	Hook Latch Kit (Not shown)	
	23380691	Hook Assembly (Incl. Ref. Nos. 2, 3, 4)	
1	N/A	Trunnion Crosshead	1
2	N/A	Hook & Nut Assembly	1
3	N/A	Thrust Bearing	1
4	N/A	Roll Pin	1
5	N/A	Sheave Pin	1
6	N/A	Spacer Tube	2
7	N/A	Lower Block Strap	2
8	33290902	Inner Sheave Cover	2
9	N/A	Flat Washer, M8	4
10	N/A	Socket Head Cap Screw, M8	2
11	N/A	Locknut, M8	2
12	N/A	Rope Sheave	2
13	N/A	Ball Bearing	4
14	N/A	Internal Retaining Ring	2
15	N/A	External Retaining Ring	2
16	33290912	Outer Sheave Cover	2
17	23382810	5t Capacity Label	2
18a	23382801	SHAW-BOX Brand Label	2
18b	23382802	Yale Brand Label	2
19	N/A	Socket Head Cap Screw, M6	6
20	N/A	Locknut, M6	6

“C” Frame: Lower Block Components for Figure 9-4a.

REF. No.	Part Number	Description	Qty. Req'd
	44934901C	10t Lower Block Assembly (Excludes Ref. Nos. 17 & 18)	1
	44934901C	7.5t Lower Block Assembly (Excludes Ref. Nos. 17 & 18)	1
	33292101	Sheave Assembly (Incl. Ref. Nos. 12, 13, 14)	
	4X1315	Hook Latch Kit (Not shown)	
	23389291	Hook Assembly (Incl. Ref. Nos. 2, 3, 4)	
1	N/A	Trunnion Crosshead	1
2	N/A	Hook & Nut Assembly	1
3	N/A	Thrust Bearing	1
4	N/A	Roll Pin	1
5	N/A	Sheave Pin	1
6	N/A	Spacer Tube	2
7	N/A	Lower Block Strap	2
8	33291802	Inner Sheave Cover	2
9	N/A	Flat Washer, M12	4
10	N/A	Socket Head Cap Screw, M12	2
11	N/A	Locknut, M12	2
12	N/A	Rope Sheave	2
13	N/A	Ball Bearing	4
14	N/A	Internal Retaining Ring	2
15	N/A	External Retaining Ring	2
16	33291812	Outer Sheave Cover	2
17	-	Capacity Label	2
	23282812	10t Capacity Plate	
	23382811	7.5t Capacity Plate	
18a	23382801	SHAW-BOX Brand Label	2
18b	23382802	Yale Brand Label	2
19	N/A	Socket Head Cap Screw, M8	6
20	N/A	Locknut, M8	6

“D” Frame: Lower Block Components for Figure 9-4a.

REF. No.	Part Number	Description	Qty. Req'd
	44936901C	Lower Block Assembly (Excludes Ref. Nos. 17 & 18)	1
	33293701	Sheave Assembly (Incl. Ref. Nos. 12, 13, 14)	
	4X1322	Hook Latch Kit (Not shown)	
	23394091	Hook Assembly (Incl. Ref. Nos. 2, 3, 4)	
1	N/A	Trunnion Crosshead	1
2	N/A	Hook & Nut Assembly	1
3	N/A	Thrust Bearing	1
4	N/A	Roll Pin	1
5	N/A	Sheave Pin	1
6	N/A	Spacer Tube	2
7	N/A	Lower Block Strap	2
8	33292801	Inner Sheave Cover	2
9	N/A	Flat Washer, M12	4
10	N/A	Threaded Stud, M12	2
11	N/A	Locknut, M12	2
12	N/A	Rope Sheave	2
13	N/A	Ball Bearing	4
14	N/A	Internal Retaining Ring	2
15	N/A	External Retaining Ring	2
16	33292811	Outer Sheave Cover	2
17	23391525	15t Capacity Label	2
18a	23391501	SHAW-BOX Brand Label	2
18b	23391502	Yale Brand Label	2
19	N/A	Socket Head Cap Screw, M8	6
20	N/A	Locknut, M8	6

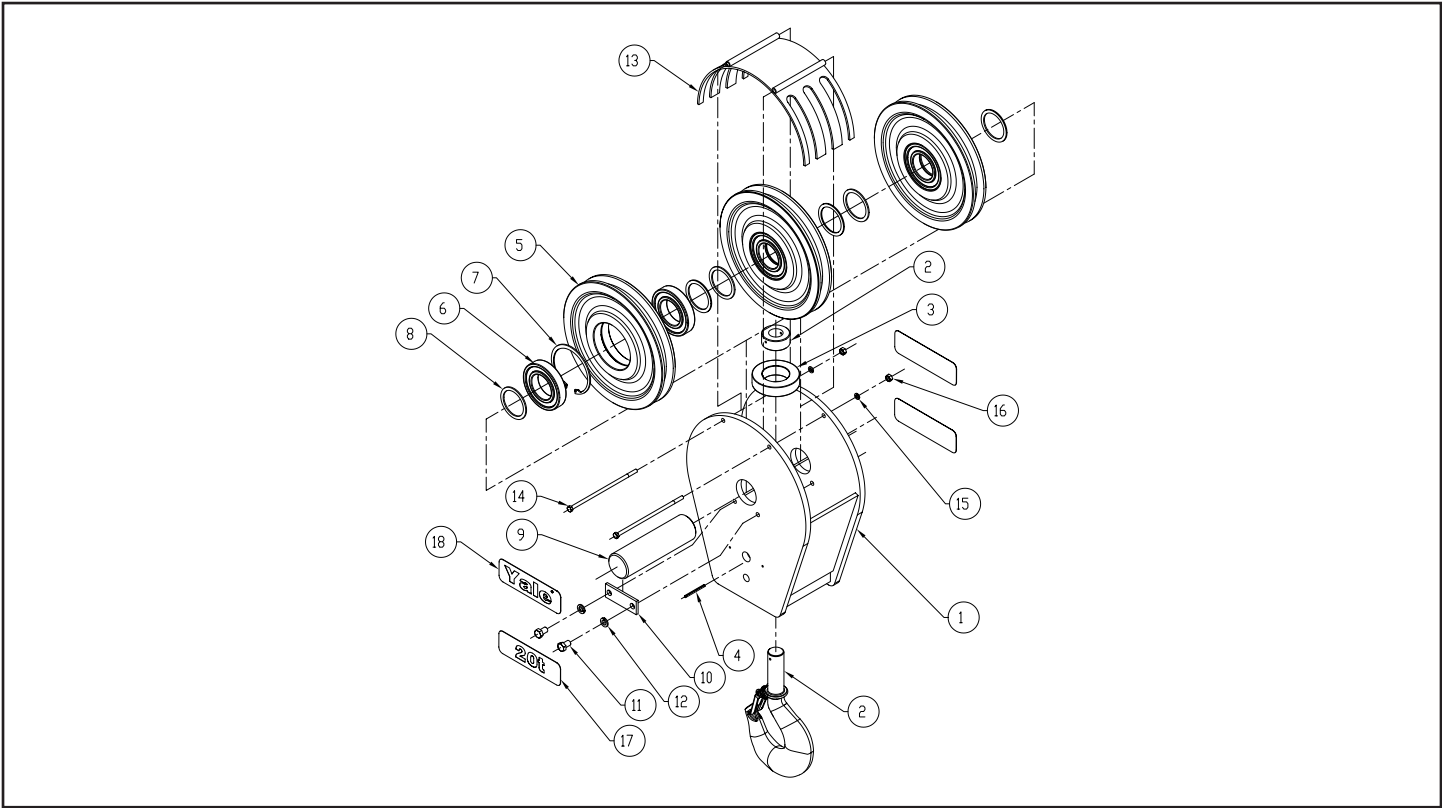

Figure 9-4b. Lower Block Assembly (“D” Frame, 20t Capacity)

“B” Frame: Lower Block Components for Figure 9-4a.

REF. No.	Part Number	Description	Qty. Req'd
	44937301C	Lower Block Assembly (Excludes Ref. Nos. 17 & 18)	1
	33294601	Sheave Assembly (Incl. Ref. Nos. 5, 6, 7)	
	10572320	Hook Latch Kit (Not Shown)	
	31322812	Hook Assembly (Incl. Ref. Nos. 2, 3, 4)	
1	N/A	Lower Block Weldment	1
2	N/A	Hook & Nut Assembly	1
3	N/A	Thrust Bearing	1
4	N/A	Roll Pin	1
5	N/A	Rope Sheave	3
6	N/A	Ball Bearing	6
7	N/A	Internal Retaining Ring	3
8	N/A	Spacer	6
9	N/A	Sheave Pin	1
10	N/A	Keeper Plate	1
11	N/A	Hex Head Bolt, 1/2-13	2
12	N/A	Lockwasher, 1/2	2
13	44937801	Sheave Guard	1
14	N/A	Hex Head Bolt, 5/16-18	2
15	N/A	Lockwasher, 5/16	2
16	N/A	Locknut, 5/16	2
17	23391530	20t Capacity Label	1
18a	23391501	SHAW-BOX Brand Label	2
18b	23391502	Yale Brand Label	2

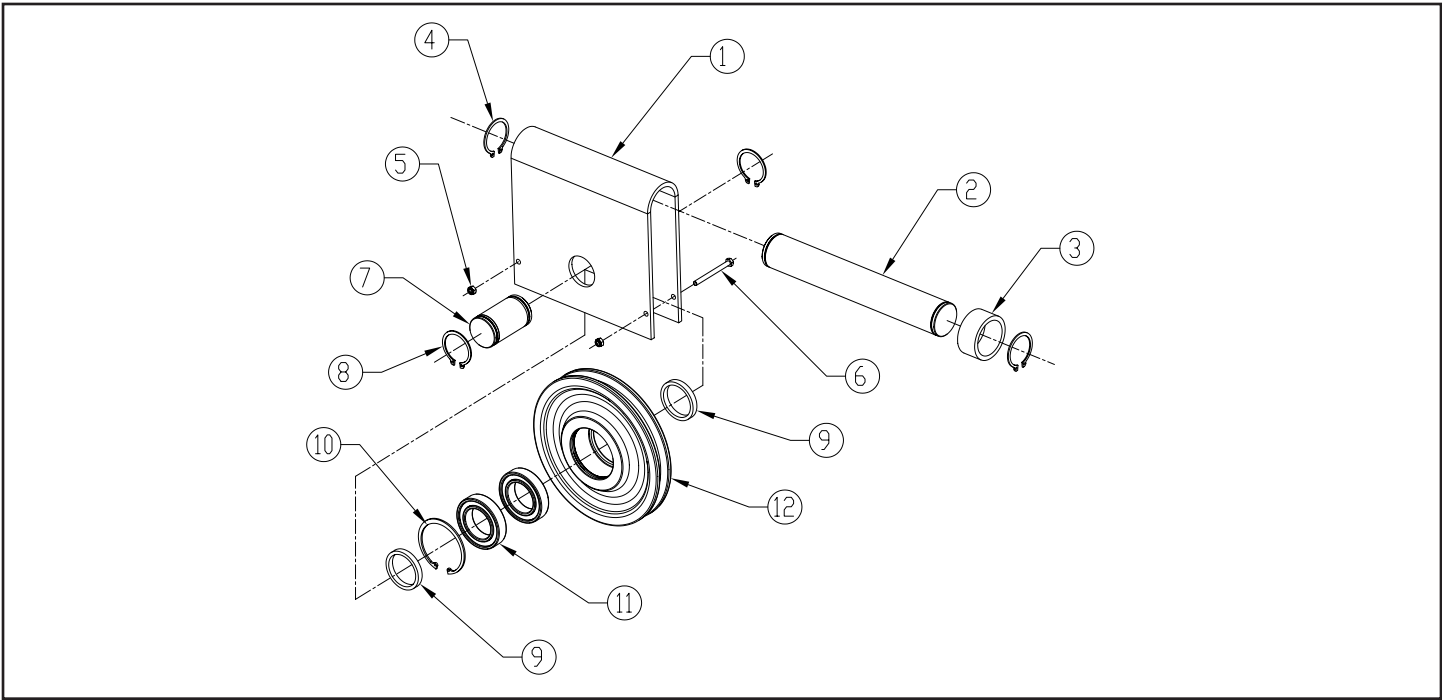

Figure 9-5a. Upper Block Assembly

“B” Frame: Upper Block Components for Figure 9-5a.

REF. No.	Part Number	Description	Qty. Req'd
	44932701	“B” Frame Hoist Upper Block Assembly	1
	33290601	Sheave Assembly (Incl. Ref. Nos. 10, 11, 12)	1
1	N/A	Upper Block Yoke	1
2	N/A	Yoke Pin	1
3	N/A	Yoke Spacer (“B” Frame Only)	1
4	N/A	External Retaining Ring	2
5	N/A	Locknut, M6	2
6	N/A	Hex Head Bolt, M6	2
7	N/A	Sheave Pin	1
8	N/A	External Retaining Ring	2
9	N/A	Spacer Washer	2
10	N/A	Internal Retaining Ring	1
11	N/A	Sealed Ball Bearing	2
12	N/A	Rope Sheave	1

“C” Frame: Upper Block Components for Figure 9-5a.

REF. No.	Part Number	Description	Qty. Req'd
	44934601C	“C” Frame Hoist Upper Block Assembly	1
	33292101	Sheave Assembly (Incl. Ref. Nos. 10, 11, 12)	
1	N/A	Upper Block Yoke	1
2	N/A	Yoke Pin	1
3	N/A	Yoke Spacer (Not Required on “C” Frame)	0
4	N/A	External Retaining Ring	2
5	N/A	Locknut, M6	2
6	N/A	Hex Head Bolt, M6	2
7	N/A	Sheave Pin	1
8	N/A	External Retaining Ring	2
9	N/A	Spacer Washer	2
10	N/A	Internal Retaining Ring	1
11	N/A	Sealed Ball Bearing	2
12	N/A	Rope Sheave	1

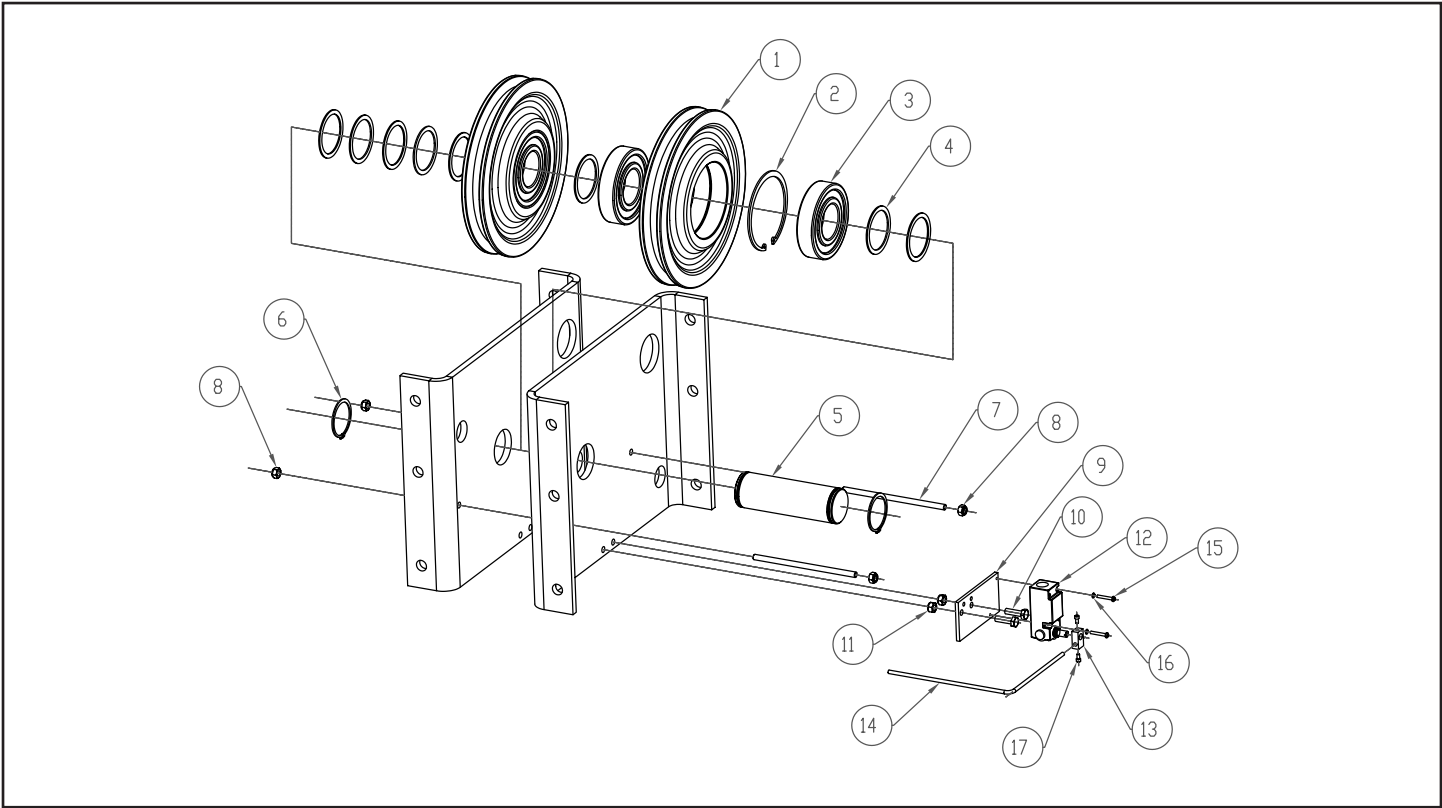

Figure 9-5b. Upper Block Assembly (“D” Frame, 20t)

“D” Frame: Upper Block Components for Figure 9-5b.			
REF. No.	Part Number	Description	Qty. Req'd
	33294601	Sheave Assembly (Incl. Ref. Nos. 1, 2, 3)	
1	N/A	Rope Sheave	2
2	N/A	Internal Retaining Ring	2
3	N/A	Ball Bearing	4
4	N/A	Spacer	8
5	N/A	Sheave Pin	1
6	N/A	External Retaining Ring	2
7	N/A	Threaded Stud, M10	2
8	N/A	Locknut, M10	4
	33290503C	“D” Frame Block Operated Limit Switch	1
9	N/A	Limit Switch Bracket	1
10	N/A	Hex Head Bolt, M10	2
11	N/A	Locknut, M10	2
12	N/A	Limit Switch	1
13	N/A	Limit Switch Hub	1
14	N/A	Limit Switch Rod	1
15	N/A	Pan Head Screw, #10	2
16	N/A	Lockwasher, #10	2

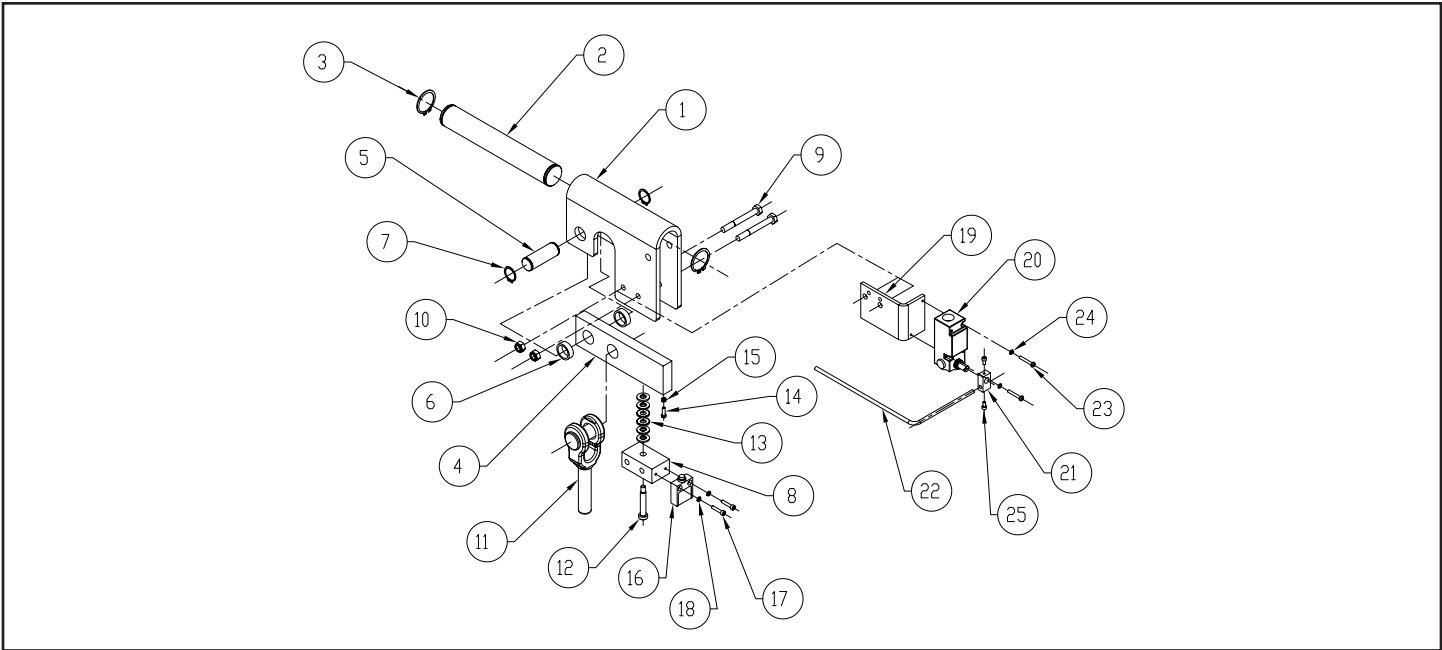

Figure 9-6a. Wire Rope Dead End Assembly with Limit Switch (“B” & “C” Frame)

“B” Frame: Wire Rope Dead End Assembly Components for Figure 9-6a.

REF. No.	Part Number	Description	Qty. Req'd
	44932801C	“B” Frame Hoist Rope and Dead End Assembly (Excl. Ref. Nos. 11, 19 - 25)	1
1	N/A	Dead End Yoke	1
2	N/A	Yoke Pin	1
3	N/A	External Retaining Ring	2
4	N/A	Overload Beam	1
5	N/A	Dead End Pin	1
6	N/A	Spacer	2
7	N/A	External Retaining Ring	2
8	N/A	Overload Spring Base	1
9	N/A	Hex Head Bolt, M6	2
10	N/A	Locknut, M6	2
11	-	Wire Rope and Swaged End Assembly	1
	23383601	Rope Assembly, 25’ Lift Model, 9mm	
	23383602	Rope Assembly, 40’ Lift Model, 9mm	
	23383605	Rope Assembly, 60’ Lift Model, 9mm	
12	N/A	Socket Head Shoulder Bolt, M8 Thread	1
13	N/A	Belleville Spring Washer	4
14	N/A	Hex Head Bolt, M5	1
15	N/A	Plain Hex Nut, M5	1
16	N/A	Limit Switch	1
17	N/A	Socket Head Cap Screw, M5	2
18	N/A	Hi-Collar Lockwasher	2
	33290502C	“B” Frame Block Operated Limit Switch	1
19	N/A	Limit Switch Bracket	1
20	N/A	Limit Switch	1
21	N/A	Limit Switch Hub	1
22	N/A	Actuator Rod	1
23	N/A	Pan Head Screw, #10	2
24	N/A	Lockwasher, #10	2
25	N/A	Socket Head Cap Screw, #10	2

“C” Frame: Wire Rope Dead End Assembly Components for Figure 9-6a.

REF. No.	Part Number	Description	Qty. Req'd
	44934701C	“C” Frame Hoist Rope and Dead End Assembly (Excl. Ref. Nos. 11, 19 - 25)	1
1	N/A	Dead End Yoke	1
2	N/A	Yoke Pin	1
3	N/A	External Retaining Ring	2
4	N/A	Overload Beam	1
5	N/A	Dead End Pin	1
6	N/A	Spacer	2
7	N/A	External Retaining Ring	2
8	N/A	Overload Spring Base	1
9	N/A	Hex Head Bolt, M10	2
10	N/A	Locknut, M10	2
11	-	Wire Rope and Swaged End Assembly	1
	23386501	Rope Assembly, 25' Lift Model, 12mm	
	23386502	Rope Assembly, 40' Lift Model, 12mm	
	23386505	Rope Assembly, 60' Lift Model, 12mm	
12	N/A	Socket Head Shoulder Bolt, M8 Thread	1
13	N/A	Belleville Spring Washer	6
14	N/A	Hex Head Bolt, M5	1
15	N/A	Plain Hex Nut, M5	1
16	N/A	Limit Switch	1
17	N/A	Socket Head Cap Screw, M5	2
18	N/A	Hi-Collar Lockwasher	2
	33290502C	“C” Frame Block Operated Limit Switch	1
19	N/A	Limit Switch Bracket	1
20	N/A	Limit Switch	1
21	N/A	Limit Switch Hub	1
22	N/A	Actuator Rod	1
23	N/A	Pan Head Screw, #10	2
24	N/A	Lockwasher, #10	2
25	N/A	Socket Head Cap Screw, #10	2

NOTES

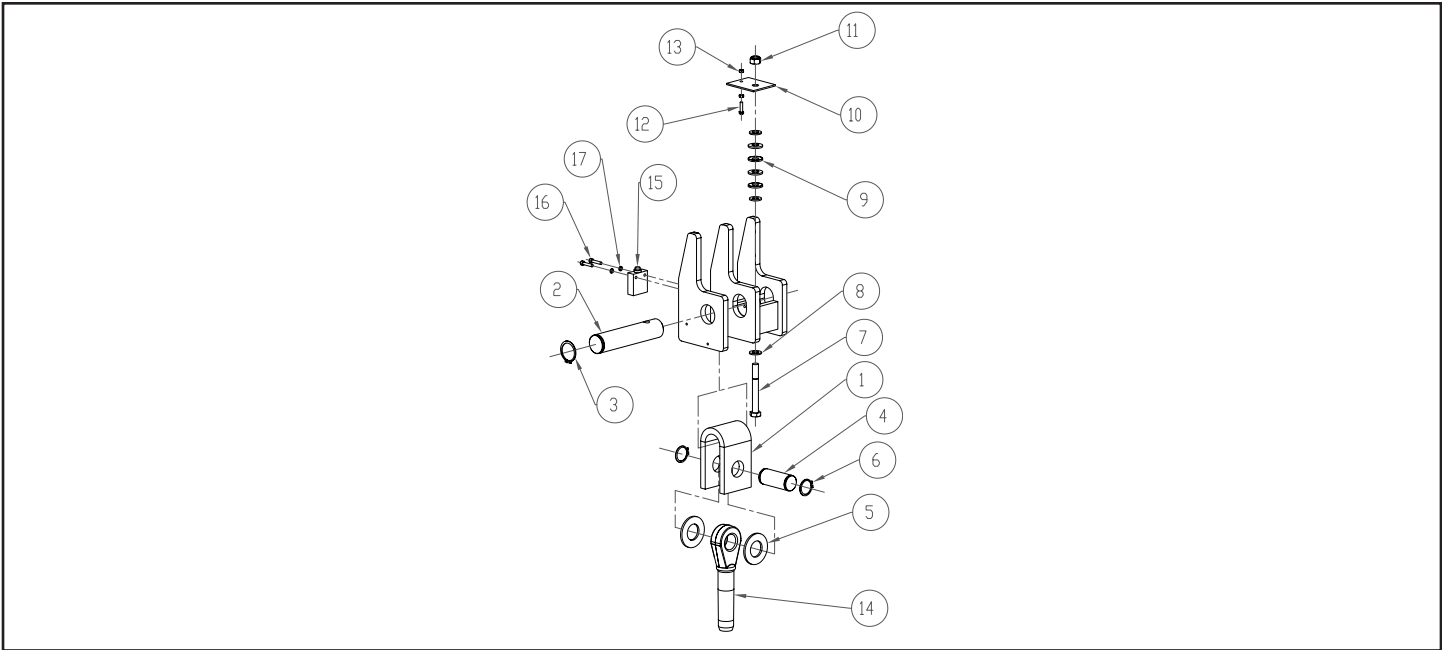

Figure 9-6b. Wire Rope Dead End Assembly with Limit Switch ("D" Frame)

"D" Frame: Wire Rope Dead End Assembly Components for Figure 9-6b.			
REF. No.	Part Number	Description	Qty. Req'd
	44937001C	"D" Frame Hoist Rope and Dead End Assembly (Excl. Ref. Nos. 14)	1
1	N/A	Dead End Yoke	1
2	N/A	Yoke Pin	1
3	N/A	External Retaining Ring	1
4	N/A	Dead End Pin	1
5	N/A	Spacer	2
6	N/A	External Retaining Ring	2
7	N/A	Hex Head Bolt, M12	1
8	N/A	Flat Washer, M12	3
9	N/A	Belleville Spring Washer	4
10	N/A	Overload Plate	1
11	N/A	Locknut, M12	1
12	N/A	Hex Head Bolt, M5	1
13	N/A	Plain Hex Nut, M5	2
14	-	Wire Rope and Swaged End Assembly	1
	23393901	Rope Assembly, 25' Lift Model, 15mm (4/1 Reeved)	
	23393902	Rope Assembly, 40' Lift Model, 15mm (4/1 Reeved)	
	23393906	Rope Assembly, 60' Lift Model, 15mm (4/1 Reeved)	
	23484502	Rope Assembly, 16' Lift Model, 9/16" (6/1 Reeved)	
	23484501	Rope Assembly, 26' Lift Model, 9/16" (6/1 Reeved)	
	23484505	Rope Assembly, 40' Lift Model, 9/16" (6/1 Reeved)	
15	N/A	Limit Switch	1
16	N/A	Socket Head Cap Screw, M5	2
17	N/A	Hi-Collar Lockwasher, M5	2

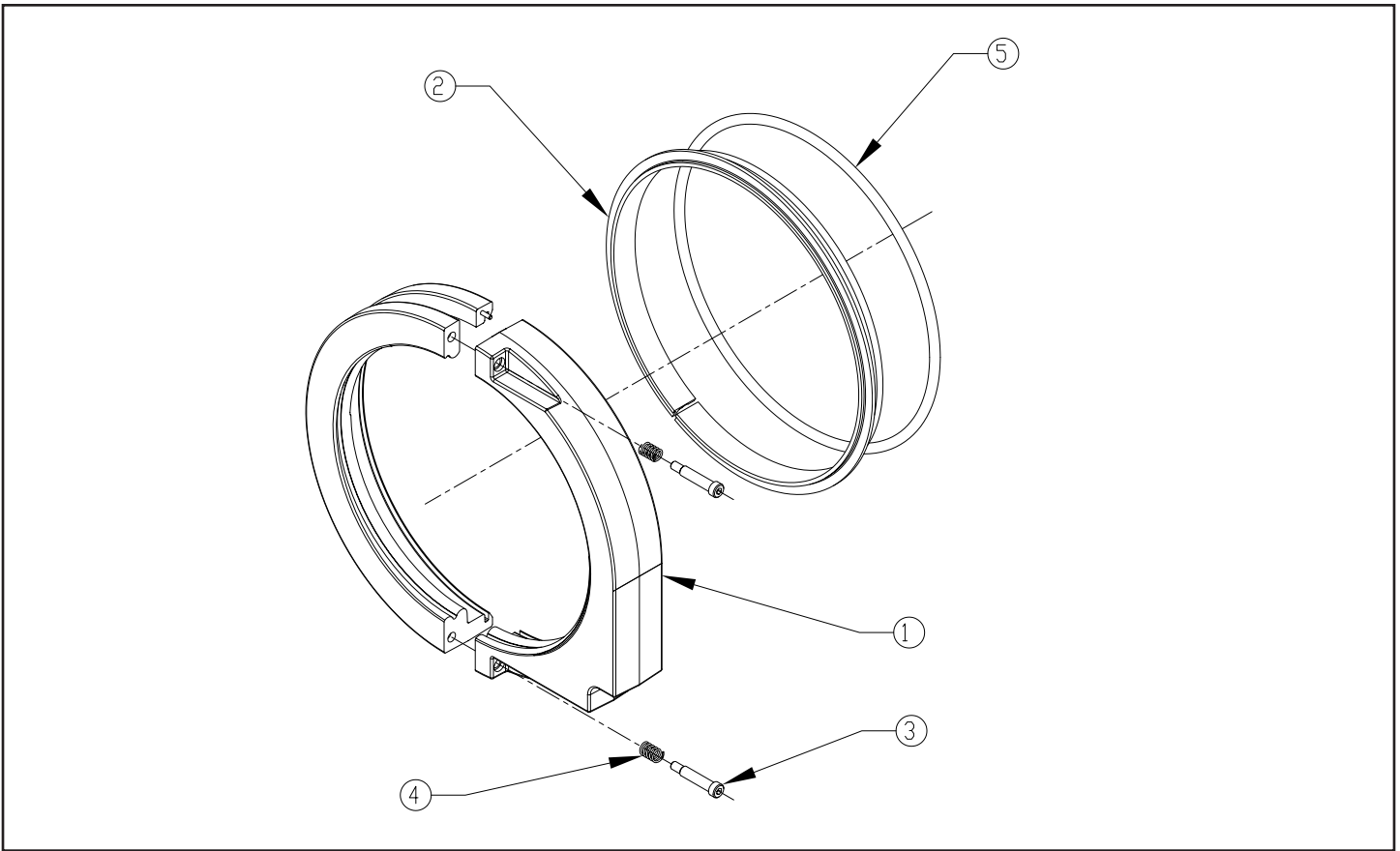

Figure 9-7a. Rope Guide Assembly (“B” & “C” Frame)

“B” Frame: Rope Guide Components for Figure 9-7a.

REF. No.	Part Number	Description	Qty. Req'd
	44931801C	“B” Frame Rope Guide Assembly	1
1	N/A	Rope Guide Body	1
2	N/A	Plastic Shroud	1
3	N/A	Socket Head Shoulder Bolt, M6 Thread	2
4	N/A	Compression Spring	2
5	N/A	Extension Spring	1

“C” Frame: Rope Guide Components for Figure 9-7a.

REF. No.	Part Number	Description	Qty. Req'd
	44933801C	“C” Frame Rope Guide Assembly	1
1	N/A	Rope Guide Body	1
2	N/A	Plastic Shroud	1
3	N/A	Socket Head Shoulder Bolt, M6 Thread	2
4	N/A	Compression Spring	2
5	N/A	Extension Spring	1

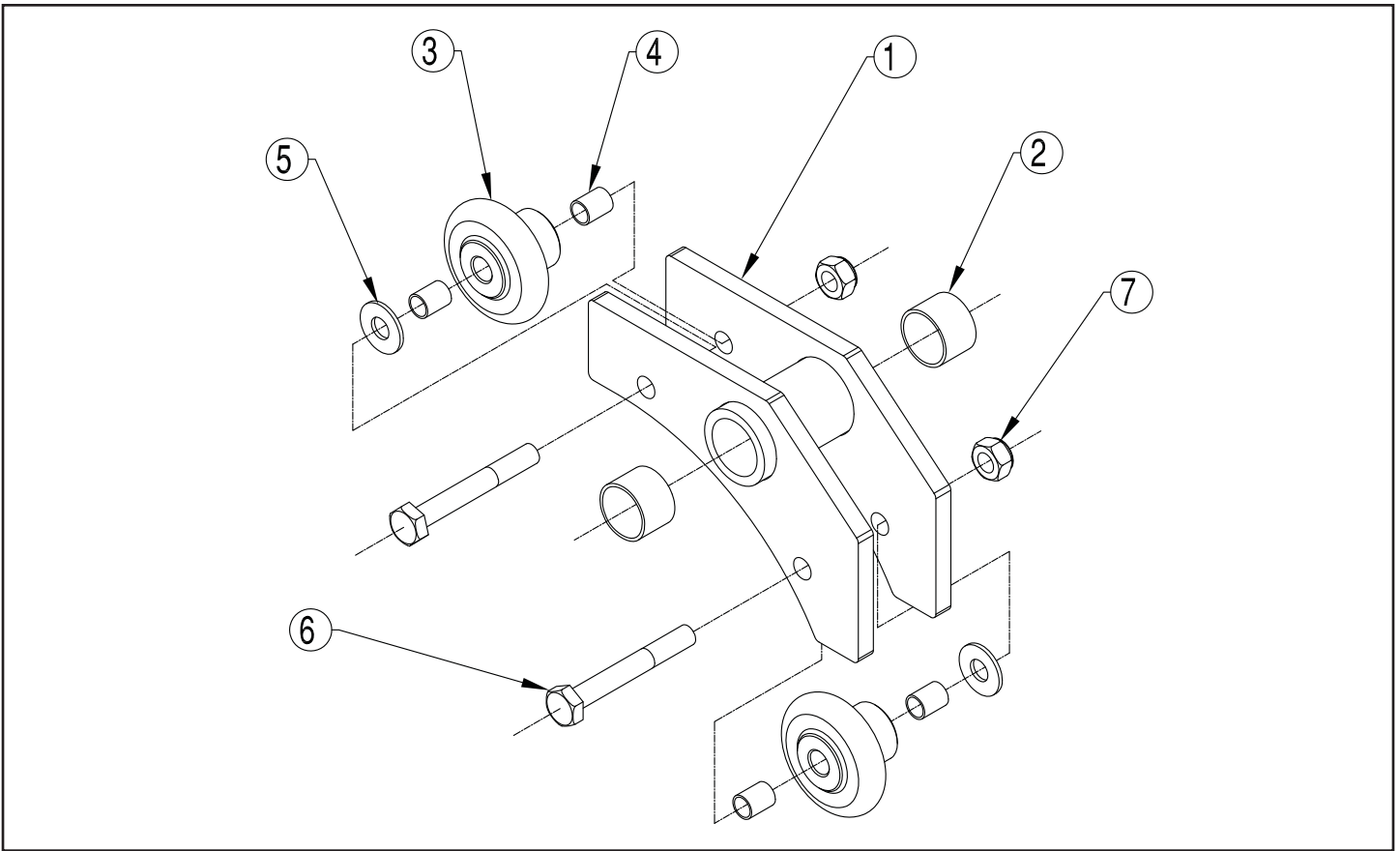

Figure 9-7b. Rope Guide Assembly (15 TONNE “D” Frame)

15 TONNE “D” Frame: Rope Guide Components for Figure 9-7b.

REF. No.	Part Number	Description	Qty. Req'd
	33293401C	15 TONNE “D” Frame Rope Guide Assembly	1
1	N/A	Rope Guide Body	1
2	N/A	Hub Bushing	2
3	N/A	Guide Roller	2
4	N/A	Roller Bushing	4
5	N/A	Washer, 3/8”	2
6	N/A	Hex Head Bolt, M10	2
7	N/A	Locknut, M10	2

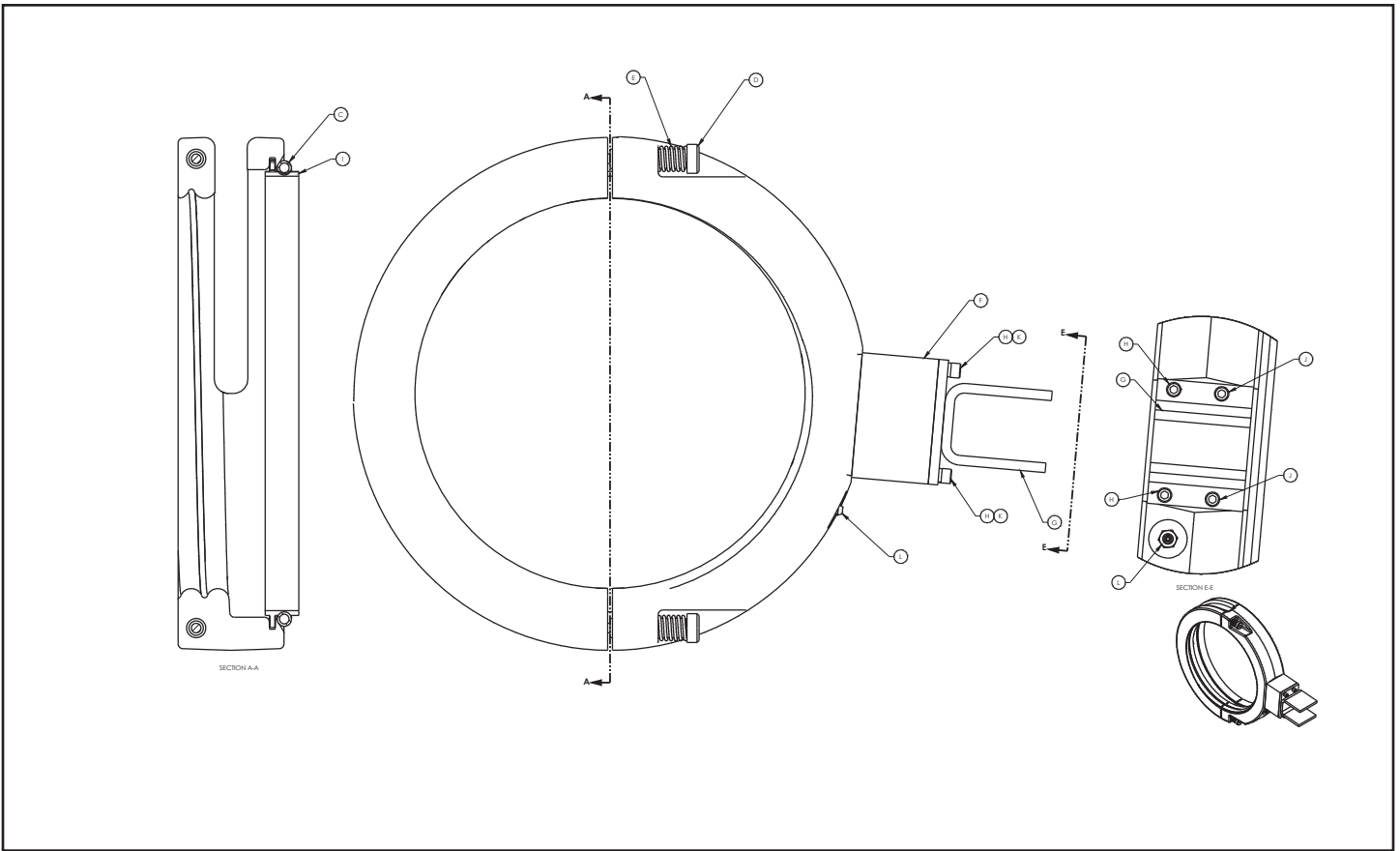

Figure 9-7c. Rope Guide Assembly (20 TONNE "D" Frame)

"D" Frame: Rope Guide Components for Figure 9-7a.

REF. No.	Part Number	Description	Qty. Req'd
	44938301C	20 TONNE "D" Frame Rope Guide Assembly	1
A	N/A	Wrap Around Style Rope Guide	1
C	N/A	Spring Extension - Music Wire PL	1
D	N/A	Screw Shoulder Hex Socket 3/8-16 x 2" LG	2
E	N/A	Spring Compression - Music Wire	2
F	N/A	Anti Rotation Riser Plate	1
G	N/A	Anti Rotation Bracket	1
H	N/A	Socket Head Cap Screw 1/4-20 x 3-1/4" LG Plated	2
J	N/A	Socket Head Cap Screw 1/4-20 x 2-3/4" LG Plated	2
K	N/A	1/4" Lockwasher Plated	4
L	N/A	Lubrication Fitting	1
1	N/A	Plastic Shroud	1

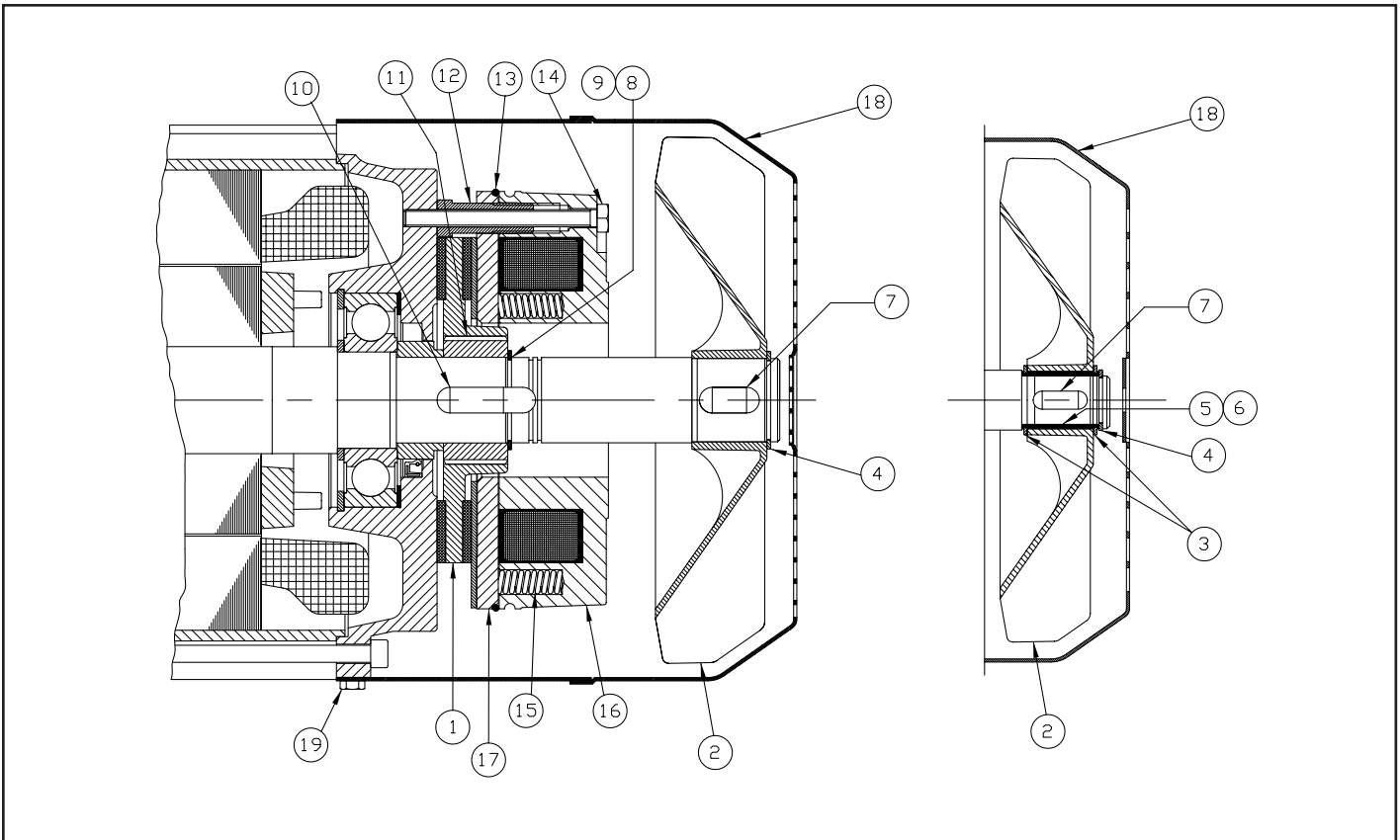

Figure 9-8a. Standard Hoist Motor Brake (ABM Motor)

"B" Frame: Hoist Brake Components for Figure 9-8a. (ABM Motor)

REF. No.	Part Number	Description	Qty. Req'd
	33313849	Complete Brake Assembly (Includes Ref. Nos. 1,11,16,17 & P/N 33313853)	1
1	33313850	Brake Friction Disc	1
2		Fan	1
3	33313851	External Retaining Rings (Fan Hub)	2
4	BRAKE	External Retaining Ring (Fan)	1
5	FAN	Fan Hub	1
6	KIT	Key (Fan Hub)	1
7		Key (Fan)	1
8	33313852	External Retaining Ring (Brake Hub)	1
9	BRAKE	Spacer (Brake Hub)	1
10	HUB	Key (Brake Hub)	1
11	KIT	Brake Hub	1
12	33313853	Hollow Core Bolts	3
13	HARD-	O-Ring	1
14	WARE	Bolts (Brake Mounting)	3
15	KIT	Compression Springs	7
16	N/A	Magnet Body - Order Complete Brake	1
17	N/A	Armature Plate - Order Complete Brake	1
18	33313855	Fan Shroud	1
19	SHROUD KIT	Bolts (Fan Shroud)	4

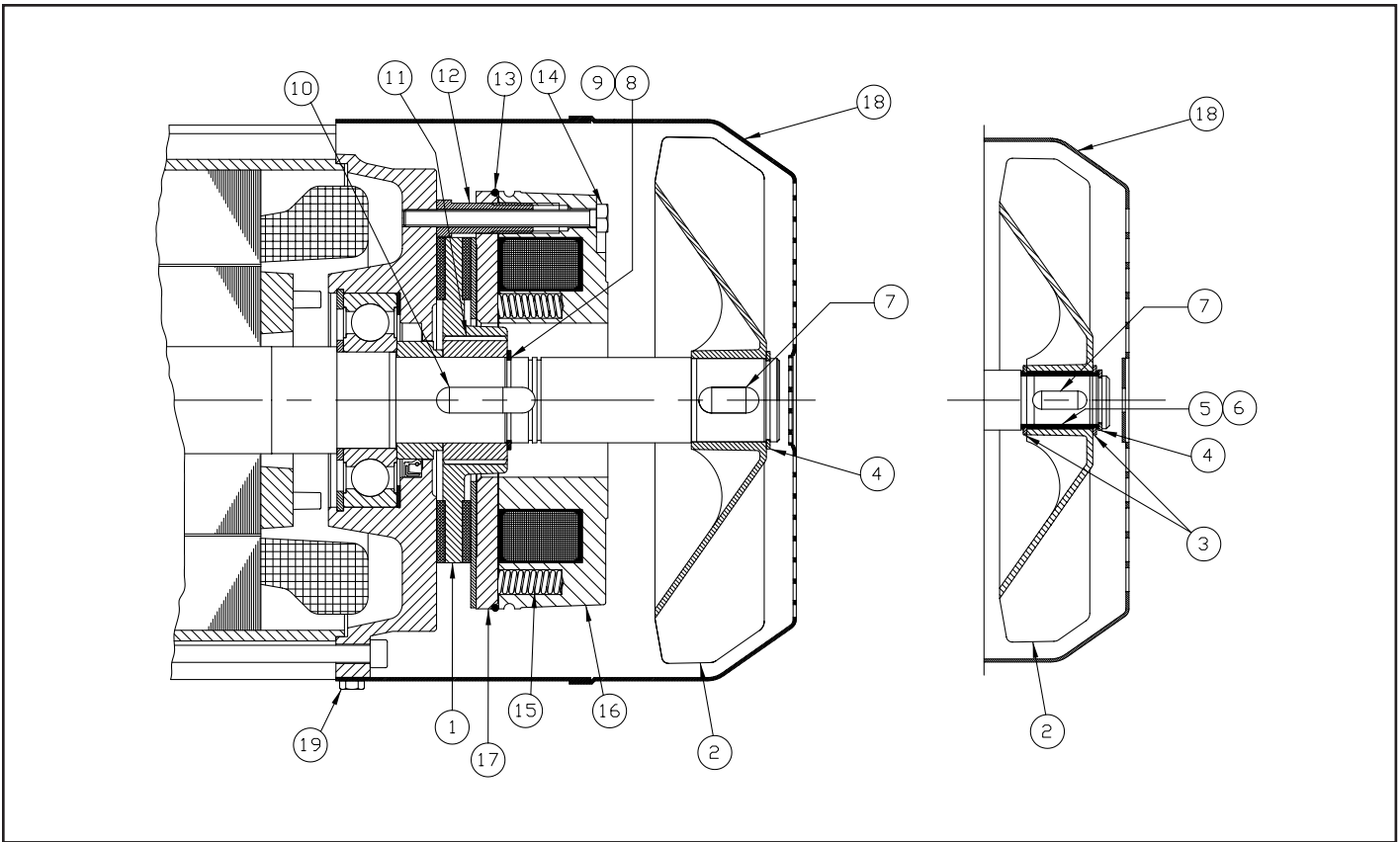

Figure 9-8b. Standard Hoist Motor Brake (ABM Motor)

"C" & "D" Frame: Hoist Brake Components for Figure 9-8c. (ABM Motor)

REF. No.	Part Number	Description	Qty. Req'd
	33263249	Complete Brake Assembly (Includes Ref. Nos. 1,11,16,17 & P/N 33263253)	1
1	33263250	Brake Friction Disc	1
2		Fan	1
3	33263251	External Retaining Rings (Fan Hub)	2
4	BRAKE	External Retaining Ring (Fan)	1
5	FAN	Fan Hub	1
6	KIT	Key (Fan Hub)	1
7		Key (Fan)	1
8	33263252	External Retaining Ring (Brake Hub)	1
9	BRAKE	Spacer (Brake Hub)	1
10	HUB	Key (Brake Hub)	1
11	KIT	Brake Hub	1
12	33263253	Hollow Core Bolts	3
13	HARD-	O-Ring	1
14	WARE	Bolts (Brake Mounting)	3
15	KIT	Compression Springs	7
16	N/A	Magnet Body - Order Complete Brake	1
17	N/A	Armature Plate - Order Complete Brake	1
18	33263255	Fan Shroud	1
19	SHROUD KIT	Bolts (Fan Shroud)	4

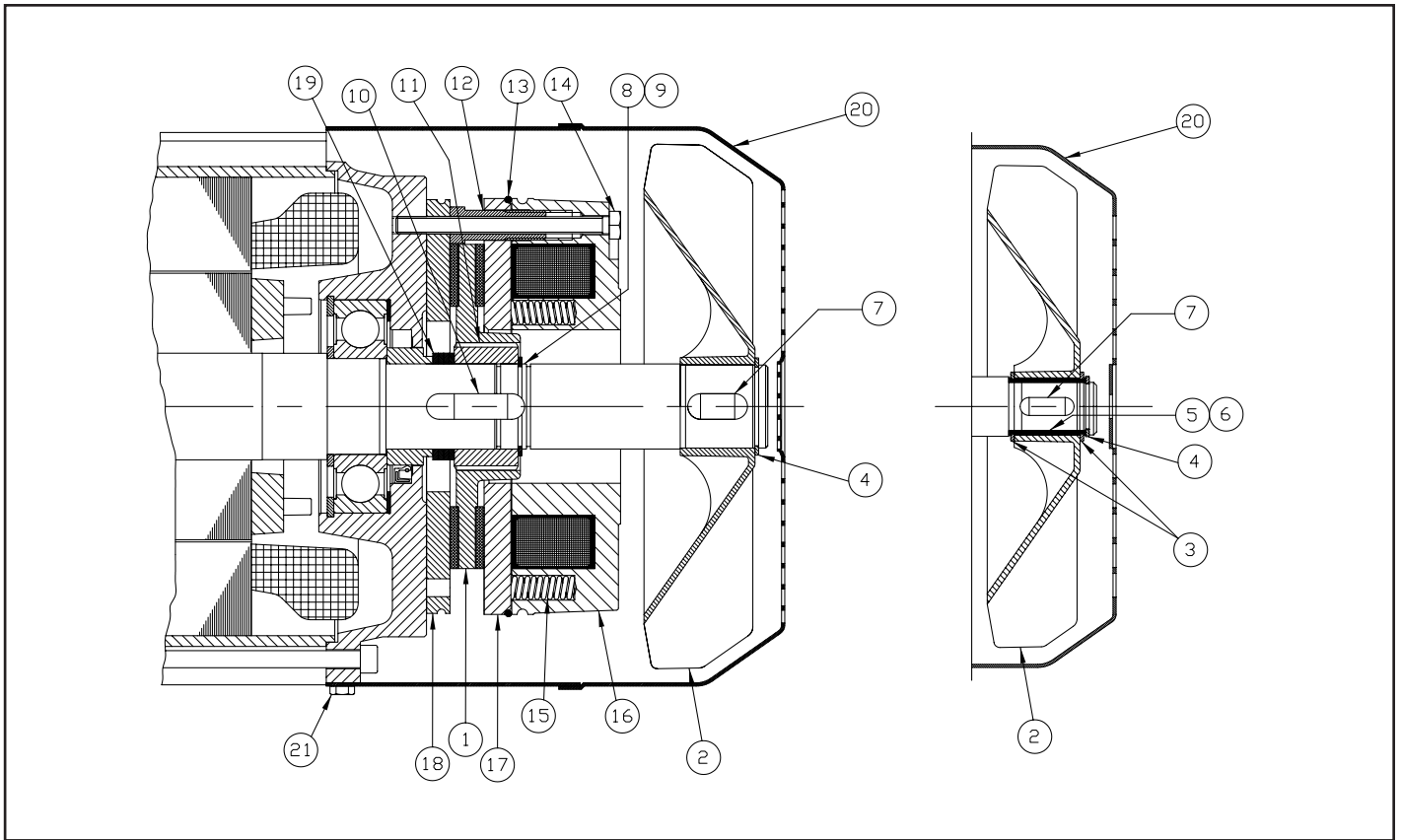

Figure 9-9a. Outdoor Service Hoist Motor Brake (ABM Motor)

"B" Frame: Hoist Brake Components for Figure 9-9a. (ABM Motor)

REF. No.	Part Number	Description	Qty. Req'd
	33294049	Complete Brake Assembly (Includes Ref. Nos. 1,11,16,17, 18 & P/N 33294053)	1
1	33313850	Brake Friction Disc	1
2		Fan	1
3	33313851	External Retaining Rings (Fan Hub)	2
4	BRAKE	External Retaining Ring (Fan)	1
5	FAN	Fan Hub	1
6	KIT	Key (Fan Hub)	1
7		Key (Fan)	1
8	33294052	External Retaining Ring (Brake Hub)	1
9	BRAKE	Spacer (Brake Hub)	1
10	HUB	Key (Brake Hub)	1
11	KIT	Stainless Steel Brake Hub	1
12	33294053	Hollow Core Bolts	3
13	HARD-	O-Ring	1
14	WARE	Bolts (Brake Mounting)	3
15	KIT	Compression Springs	7
16	N/A	Magnet Body - Order Complete Brake	1
17	N/A	Stainless Steel Armature Plate - Order Complete Brake	1
18	N/A	Stainless Steel Friction Disc - Order Complete Brake	1
19	11803105	Spacer Washers	4
20	33313855	Fan Shroud	1
21	SHROUD KIT	Bolts (Fan Shroud)	4

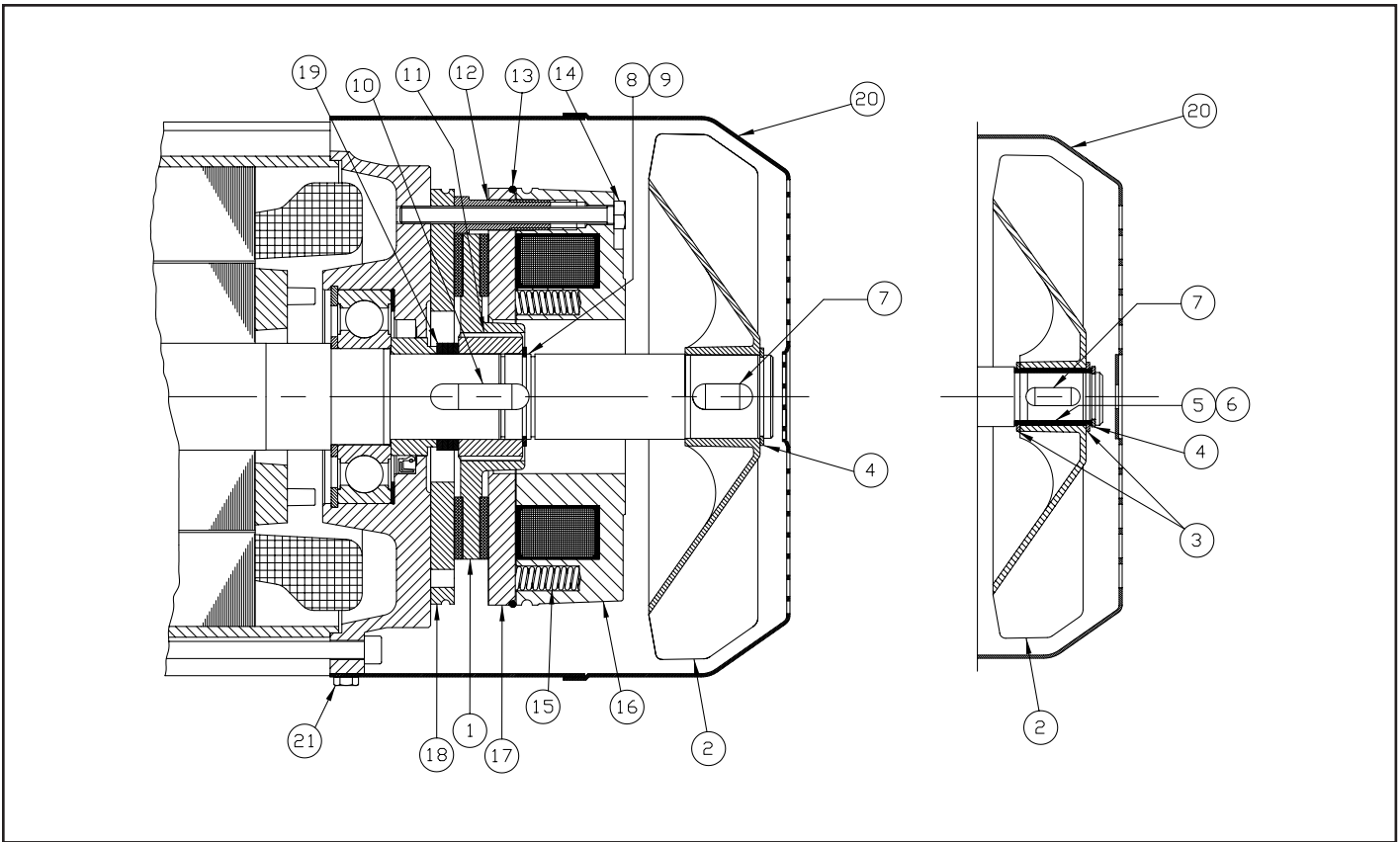
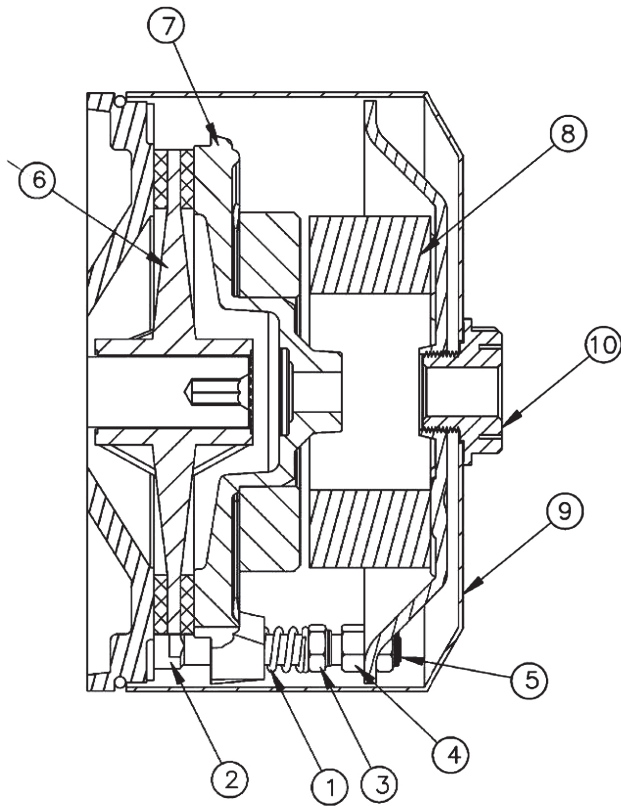

Figure 9-9b. Outdoor Service Hoist Motor Brake (ABM Motor)

"C" & "D" Frame: Hoist Brake Components for Figure 9-9b. (ABM Motor)

REF. No.	Part Number	Description	Qty. Req'd
	33294149	Complete Brake Assembly (Includes Ref. Nos. 1,11,16,17, 18 & P/N 33294153)	1
1	33263250	Brake Friction Disc	1
2		Fan	1
3	33263251	External Retaining Rings (Fan Hub)	2
4	BRAKE	External Retaining Ring (Fan)	1
5	FAN	Fan Hub	1
6	KIT	Key (Fan Hub)	1
7		Key (Fan)	1
8	33294152	External Retaining Ring (Brake Hub)	1
9	BRAKE	Spacer (Brake Hub)	1
10	HUB	Key (Brake Hub)	1
11	KIT	Stainless Steel Brake Hub	1
12	33294153	Hollow Core Bolts	3
13	HARD-	O-Ring	1
14	WARE	Bolts (Brake Mounting)	3
15	KIT	Compression Springs	7
16	N/A	Magnet Body - Order Complete Brake	1
17	N/A	Stainless Steel Armature Plate - Order Complete Brake	1
18	N/A	Stainless Steel Friction Disc - Order Complete Brake	1
19	11803106	Spacer Washers	4
20	33263255	Fan Shroud	1
21	SHROUD KIT	Bolts (Fan Shroud)	4



ITEM NO.	DESCRIPTION
1	SPRINGS
2	BRAKE ADJUSTERS
3	LOCK NUTS
4	NUTS
5	NUTS
6	BRAKE DISC
7	MOVING ELEMENT
8	BRAKE COIL
9	END COVER
10	REAR NUT

Figure 9-10a & 9-10b. Standard Hoist Motor Brake (MGM Motor)

"B" Frame: Hoist Brake Components for Figure 9-10a. (MGM Motor)

REF. No.	Part Number	Description	Qty. Req'd
	33327349	Complete Brake Assembly (Includes Ref Nos. 1-10)	1
	33327350	Brake Adjuster Set (Includes Ref Nos. 1-5)	1
6	33327351	Brake Disc	1
7	33327352	Brake Moving Element	1
8	33327353	24V DC brake Coil	1
9	33327354	Brake Cover	1
10	33327355	Plastic Hexagonal Nut (Standard Brake)	1

"C" & "D" Frame: Hoist Brake Components for Figure 9-10b. (MGM Motor)

REF. No.	Part Number	Description	Qty. Req'd
	33330749	Complete Brake Assembly (Includes Ref Nos. 1-10)	1
	33330750	Brake Adjuster Set (Includes Ref Nos. 1-5)	1
6	33330751	Brake Disc	1
7	33330752	Brake Moving Element	1
8	33330753	24V DC brake Coil	1
9	33330754	Brake Cover	1
10	33330755	Hexagonal Nut with Seal (IP55 Brake)	1

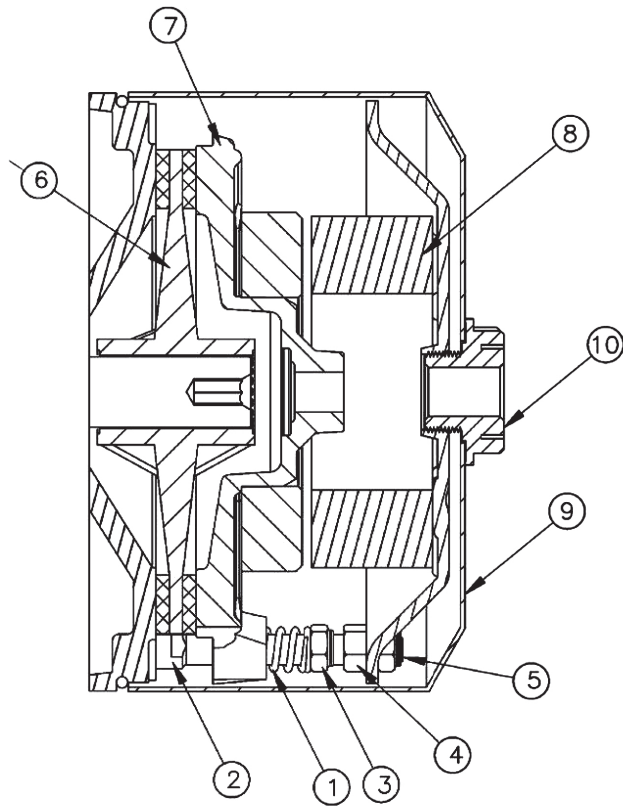

ITEM NO.	DESCRIPTION
1	SPRINGS
2	BRAKE ADJUSTERS
3	LOCK NUTS
4	NUTS
5	NUTS
6	BRAKE DISC
7	MOVING ELEMENT
8	BRAKE COIL
9	END COVER
10	REAR NUT

Figure 9-11a & 9-11b. Outdoor Service Hoist Motor Brake (MGM Motor)

"B" Frame: Hoist Brake Components for Figure 9-11a. (MGM Motor)

REF. No.	Part Number	Description	Qty. Req'd
	33327359	Complete Brake Assembly (Includes Ref Nos. 1-10)	1
	33327350	Brake Adjuster Set (Includes Ref Nos. 1-5)	1
6	33327351	Brake Disc	1
7	33327352	Brake Moving Element	1
8	33327353	24V DC brake Coil	1
9	33327354	Brake Cover	1
10	33327360	Plastic Hexagonal Nut (Standard Brake)	1

"C" & "D" Frame: Hoist Brake Components for Figure 9-11b. (MGM Motor)

REF. No.	Part Number	Description	Qty. Req'd
	33330759	Complete Brake Assembly (Includes Ref Nos. 1-10)	1
	33330750	Brake Adjuster Set (Includes Ref Nos. 1-5)	1
6	33330751	Brake Disc	1
7	33330752	Brake Moving Element	1
8	33330753	24V DC brake Coil	1
9	33330754	Brake Cover	1
10	33327360	Hexagonal Nut with Seal (IP55 Brake)	1

RECOMMENDED SPARE PARTS

Certain parts of your hoist will, in time, require replacement under normal wear conditions. It is suggested that the following parts be purchased for your hoist as spares for future use.

- One Brake Friction Disc
- One Brake Control Module
- One Brake Hardware Kit
- One Set of Contactors
- One Transformer
- One Wire Rope Assembly

Note: When ordering parts always furnish Hoist Serial Number, Catalog Number, Motor Horsepower, Voltage, Phase, Frequency and Rated Load of Hoist on which the parts are to be used.

PARTS AND SERVICES ARE AVAILABLE IN THE UNITED STATES AND IN CANADA

Parts for your hoist or trolley are available from your local authorized repair station. For the name of the nearest parts or service center, visit our website www.cmworks.com or call the Columbus McKinnon customer service department at (800) 888-0985.

WARRANTY

WARRANTY AND LIMITATION OF REMEDY AND LIABILITY

A. Seller warrants that its products and parts, when shipped, and operating (including installation, construction and start-up), when performed, will meet applicable specifications, will be of good quality and will be free from defects in material and workmanship. All claims for defective mechanical components under this warranty must be made in writing immediately upon discovery and in any event, within three (3) years from shipment of the applicable item unless Seller specifically assumes installation, construction or start-up responsibility. All claims for defective mechanical components when Seller assumes installation, construction or start-up responsibility and all claims for defective work must be made in writing immediately upon discovery and in any event, within three (3) years from completion of the applicable work by Seller, provided; however, all claims for defective mechanical components must be made in writing no later than (42) months after shipment. All claims for defective electrical components under this warranty must be made in writing immediately upon discovery and in any event, within one (1) year from shipment of the applicable item unless Seller specifically assumes installation, construction or start-up responsibility. All claims for defective electrical components when Seller assumes installation, construction or start-up responsibility and all claims for defective work must be made in writing immediately upon discovery and in any event, within one (1) year from completion of the applicable work by Seller, provided; however, all claims for defective electrical components must be made in writing no later than eighteen (18) months after shipment. Defective items must be held for Seller's inspection and returned to the original f.o.b. point upon request. THE FOREGOING IS EXPRESSLY IN LIEU OF ALL OTHER WARRANTIES WHATSOEVER, EXPRESS, IMPLIED AND STATUTORY, INCLUDING, WITHOUT LIMITATION, THE IMPLIED WARRANTIES OF MERCHANTABILITY AND FITNESS FOR A PARTICULAR PURPOSE. IN NO EVENT SHALL SELLER BE LIABLE TO BUYER OR ANY THIRD PARTY WITH RESPECT TO ANY GOOD, WHETHER

IN CONTRACT, TORT OR OTHER THEORY OF LAW, FOR LOSS OF PROFITS OR LOSS OF USE, OR FOR ANY INCIDENTAL, CONSEQUENTIAL, SPECIAL, DIRECT OR INDIRECT DAMAGES, HOWSOEVER CAUSED.

B. Upon Buyer's submission of a claim as provided above and its substantiation, Seller shall at its option either (i) repair or replace its product, part or work at either the original f.o.b. point of delivery or at Seller's authorized service station nearest Buyer; or (ii) refund an equitable portion of the purchase price. All claims are to be submitted in accordance with our published warranty process.

C. This warranty is contingent upon Buyer's proper maintenance and care of Seller's products, and does not extend to normal wear and tear. Seller reserves the right to void warranty in event of Buyer's use of inappropriate materials or application in the course of repair or maintenance, or if Seller's products have been dismantled prior to submission to Seller for warranty inspection at Seller's authorized service station.

D. Seller shall not be liable for any damage, injury or loss arising out of the use of the goods if, prior to such damage, injury or loss, such goods are: (i) damaged or misused following Seller's delivery to the carrier; (ii) not maintained, inspected, or used in compliance with applicable law and Seller's written instructions and recommendations; (iii) installed, repaired, altered or modified without compliance with such laws, instructions or recommendations; or (4) repaired with parts or accessories other than those supplied by CMCO.

E. The foregoing is Seller's only obligation and Buyer's exclusive remedy for breach of warranty and is Buyer's exclusive remedy hereunder by way of breach of contract, tort, strict liability or otherwise. Any action for breach of this agreement must be commenced within one (1) year after the cause of action has accrued.



COLUMBUS McKINNON

CORPORATION
FAMILY OF BRANDS



USA: Ph: (800) 888.0985 • (716) 689.5400 • Fax: (716) 689.5644 • www.cmworks.com

CANADA: Ph: (877) 264.6478 • Fax: (877) 264.6477 • www.cmworks.com

UK: Ph: +44 1244 375375 • Fax: +44 1244 377403 • www.cmco.eu