



WARNING

Do not use the stacker before reading and understanding this operating instructions.

NOTE!

Keep for future reference.



Operating Instructions / Parts List

Galvanised Pallet Truck

ATTENTION:

1. The waste packages should be sorted and put into solid dustbins according to the materials and be collected disposal by local special environment protection bureau. To avoid pollution, it's forbidden to throw away the wastes randomly.
2. To avoid leaking during the use of the products, the user should prepare some absorbable materials (scraps of wooden or dry duster cloth) to absorb the leaking oil in time. To avoid second pollution to the environment, the used absorbable materials should be handed in to special departments in terms of local authorities.

Thank you for using our pallet trucks. Your pallet truck is made of high quality steel and is designed for the horizontal lifting and transport of loads on a pallet or standardized containers on a level, fixed base. For your safety and correct operation, please carefully read this instruction before using it.

NOTE: All of the information reported herein is based on data available at the moment of printing. We reserves the right to modify our own products at any moment without notice and liability in any sanctions. So, it is suggested to always verify possible updates and changes.

1. GENERAL SPECIFICATIONS

Capacity	(kg)	2000
Maximum. Fork Height (mm)		200(or 190)
Minimum. Fork Height (mm)		85(or 75)
Fork Length	(mm)	1150 / 1220
Width Overall Forks	(mm)	520 / 540 / 685
Individual Fork Width	(mm)	160
Load Wheel Diameter	(mm)	Ø 80x70(or Ø 74x70) Nylon
Steering Wheel Diameter	(mm)	Ø 200(or Ø 180) Nylon

Special fork lengths are available in 800, 900, 950, 1000.

Materials and specifications are subject to change without notice.

2. ATTACHING DRAW-BAR TO PUMP UNIT

If you have purchased a wooden box of pallet truck, some assembly is required. Certainly, you need some tools, a hammer, a pliers, a spanner, etc; and some parts, one axle with hole (105), two elastic pins (106)(**Note one is in the axle (105)**), these parts are putted in a plastic bag, which is putted into the draw-bar.

NOTE: The number of draw-bar and pump should be the same.

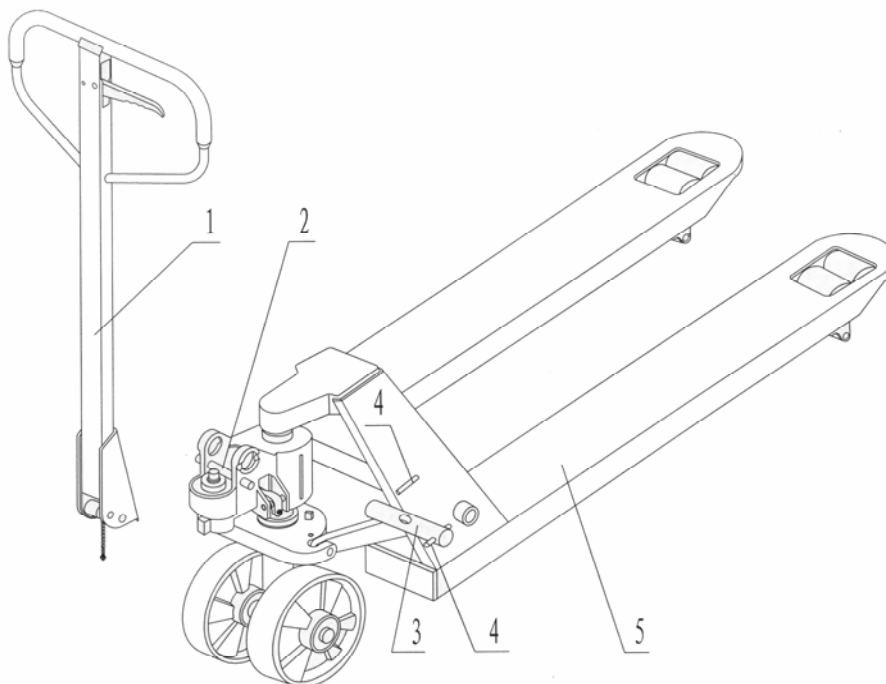

1. Draw-bar 2. Pin 3. Axle with hole 4. Elastic pin 5. Fork frame

Fig. 1

When attaching the handle, you had better squat just behind the pallet truck. Then you:

2.1 Insert the draw-bar onto the pump piston (303), then use a hammer to insert the axle with hole (105) into the hydraulic pump and draw-bar **from the right to left.** (See fig. 2).

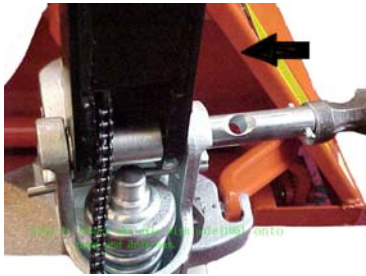

Fig. 2

2.2 Let control handle(117) to the '**LOWER**' position, then pass the adjusting nut(104), adjusting bolt(103) and chain(102Z) through the hole of axle(105) with your hand (See fig. 3).

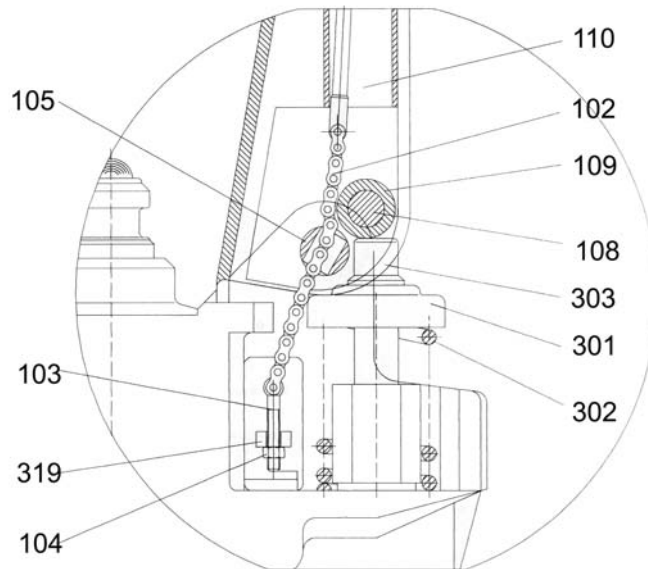

Fig. 3

2.3 Press the draw-bar (110Z) down, take away the pin(#2) (See Fig. 1).

2.4 Let the control handle (117) on '**RAISE**' position, then raise the lever plate (319) with the pin (#2) and insert the adjusting bolt (103) into the front slot of lever plate (319), note to keep the adjusting nut (104) on the under side of the lever plate.

2.5 Use a hammer to tap another elastic pin (106) into the axle with hole (105). The draw-bar is now assembled to the pump.

3. ADJUSTING RELEASE DEVICE

On the draw-bar of this pallet truck, you can find the control handle(117) which can be adjusted in three positions :

- Raise** -handle down
- Drive** -handle in center position
- Lower** -handle up, the lever moves back the drive position when released.

If however they have been changed, you can adjust according to following step:

3.1 If the forks elevate while pumping in the **DRIVE** position, turn the adjusting nut (104) on the adjusting bolt(103) or screw(318) clockwise until pumping action does not raise the forks and the

DRIVE position functions properly.

- 3.2 If the forks descend while pumping in the **DRIVE** position, turn the nut(104) or screw(318) counter-clockwise until the forks do not lower.
- 3.3 If the forks do not descent when the control handle (117) is in the **LOWER** position, turn the nut(104) or screw (318) clockwise until raising the control handle(117) lowers the forks. Then check the **DRIVE** position according to item 3.1 and 3.2 to be sure the nut (104) and screw(318) is in the proper position.
- 3.4 If the forks do not elevate while pumping in the **RAISE** position, turn the nut (104) or screw (318) counter-clockwise until the forks elevate while pumping in the **RAISE** position. Then check the **LOWER** and **DRIVE** position according to item 3.1, 3.2 and item 3.3.

4. MAINTENANCE

The pallet truck is largely maintenance-free.

4.1 OIL

Please check the oil level every six months. The oil can be hydraulic oil: ISO VG32, its viscosity should be 30cSt at 40⁰ C, total volume is about 0.4lt.

4.2 TO BANISH THE AIR

The air may come into the hydraulic oil because of transportation or pump in upset position. It can cause that the forks do not elevate while pumping in the **RAISE** position. The air can be removed in the following way: let the control handle (117) on the **LOWER** position, then move the draw-bar up and down for several times.

4.3 DAILY CHECK AND MAINTENANCE

Daily check of the pallet truck can limit wear as much as possible. Special attention should be paid to the wheels, the axles, as thread, rags, etc. It may block the wheels. The forks should be unloaded and lowered in the lowest position when the job is over.

4.4 LUBRICATION

All bearings and shafts are provided with long-life grease at the factory. You only need provide with long-life grease at monthly intervals or after each time the truck is cleaned thoroughly to the lubrication points.

5 GUIDE TO SAFETY OPERATION

- 5.1 Operator should read all warning signs and instructions here and on the pallet truck before using this truck.
- 5.2 Do not use on a slopping ground.
- 5.3 Do not operate a pallet truck unless you are familiar with it and have been trained or authorized to do so.
- 5.4 Do not operate a pallet truck unless you have checked its condition. Give special attention to the wheels or rollers, the draw-bar unit, the fork unit, the lever plate, etc. .
- 5.5 To pull the truck, always move the control handle into the drive position. This makes the draw-bar easier to move and depressurizes the pump section of the hydraulics. This preserves the hydraulic seals and the valve components. A long service life can be expected.
- 5.6 Do not take up any people on the pallet truck.
- 5.7 The operator had better take on gloves for labor protecting.

5.8 When the goods have been transported, all people should be away from the forks for 600mm.

5.9 Do not load goods like fig. 5/B .

5.10 Do not load over maximum capacity.

5.11 At others special condition or place, the operator should be carefully to operate the pallet truck.

6. TROUBLES SHOOTING

No	Trouble	Clause	Fixing Methods
1	The forks can not be lifted up the maximum height.	The hydraulic oil is not enough.	Pour in the oil.
2	The forks can not be lifted up.	Without hydraulic oil. The oil has impurities. The nut (104) is too high, keep the pumping valve open. Air come into the hydraulic oil.	Fill in the oil. Change the oil. Adjust the nut(104) or screw (318) (see item 3.4) Banish the air.(see item 4.2)
3	The forks can not be lowered.	The piston rod(328) or pump (322) is deformed resulting from partial loading slanting to one side or over-loading. The fork was kept in the high position for long time with piston rod bared to arise in rusting and jamming of the rod. The adjusting nut (104) or screw (318) is not in correct position.	Replace the piston rod (328) or pump (322). Keeping the fork in the lowest position if not using, and pay more attention to lubricate the rod. Adjust the nut (104) or screw (318) (see item 3.3)
4	Leaks	Sealing parts worn or damaged. Some part cracked or worn into small.	Replace with the new one. Replace with the new one.
5	The forks lowered without the release valve working.	The impurities in the oil cause the release valve to be unable to close tight. Some parts of hydraulic system is cracked or bored. Air come into the oil. Sealing parts worn or damaged. The adjusting nut (104) or screw (318) is not in the correct position.	Replace with new oil. Inspect and replace the waste parts. Banish the air. (See item 4.2) Replace with the new one. Adjusting the nut (104) or screw (318). (See item 3.2)

NOTE: DO NOT ATTEMP TO REPAIR THE PALLET TRUCK UNLESS YOU ARE TRAINED AND AUTHORIZED TO DO SO.

Fig. 4

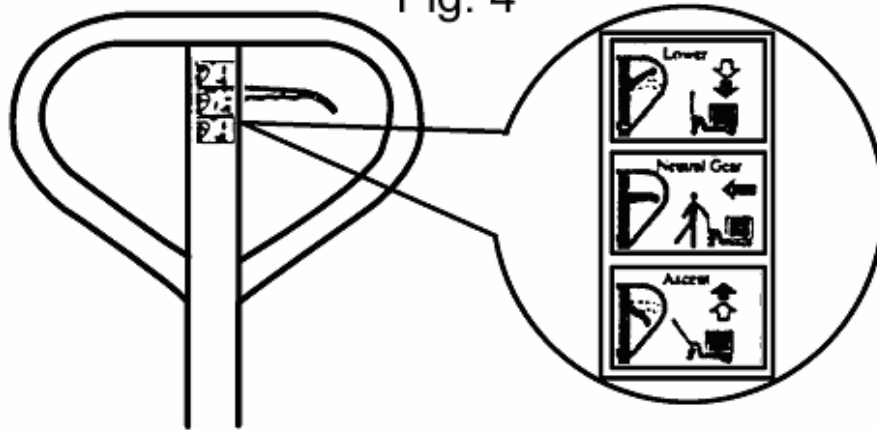
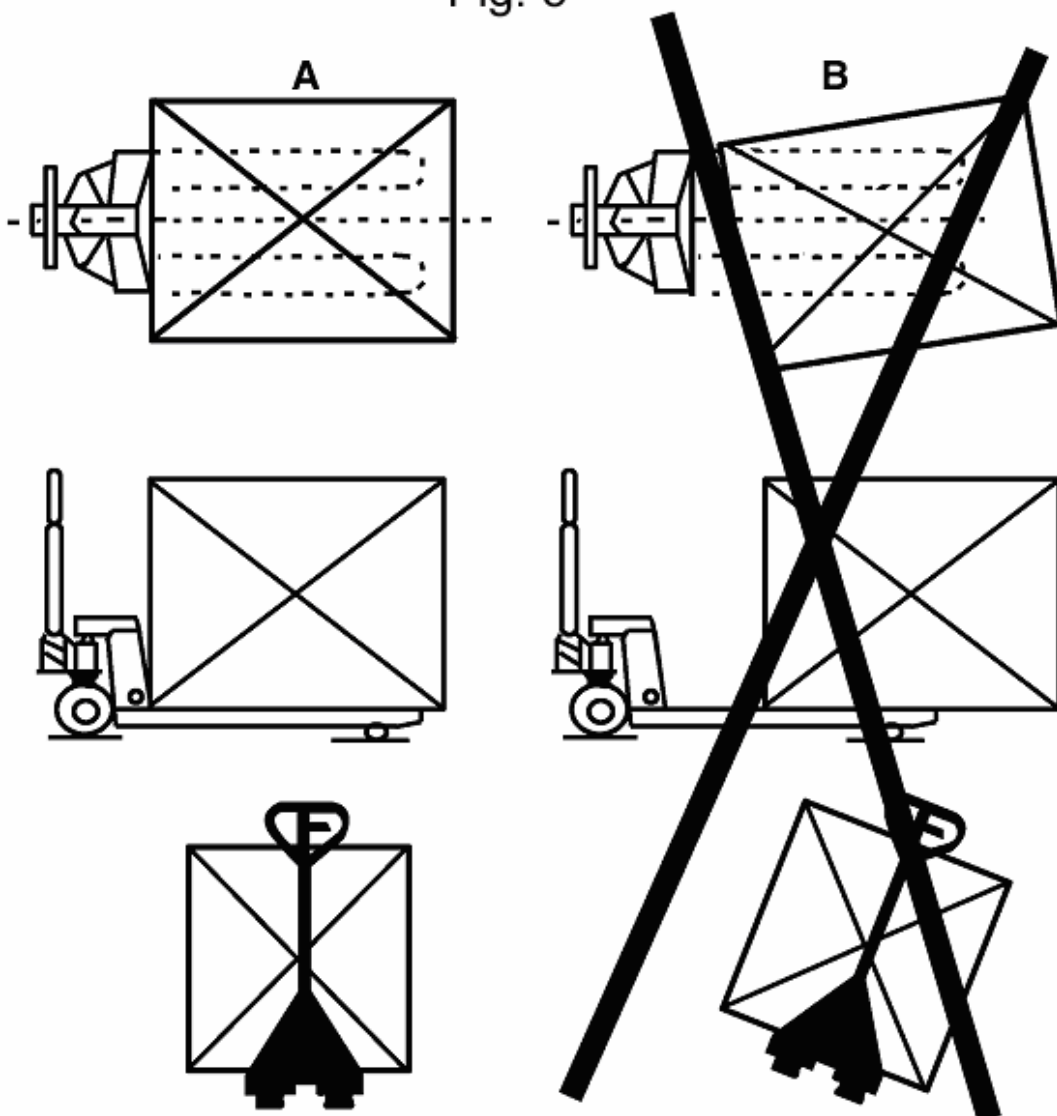
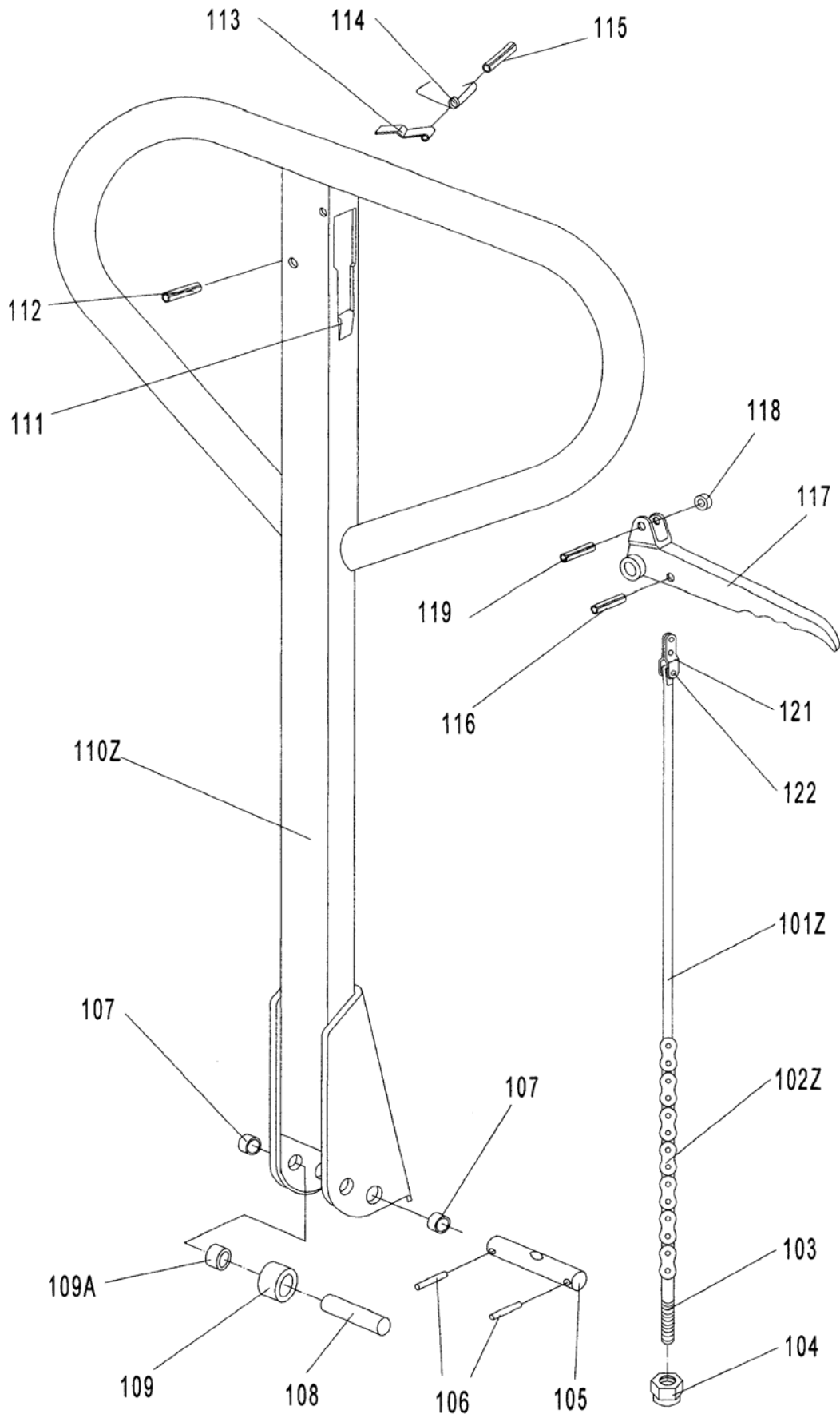

Fig. 5





LIST of DRAW-BAR

No.	Description	Quantity
101Z	Release Rod	1
102Z	Chain	1
103	Adjusting Bolt	1
104	Adjusting Nut	1
105	Axle with Hole	1
106	Elastic Pin	2
107	Bushing	2
108	Roller Pin	1
109	Pressure Roller	1
109A	Bushing	1
110Z	Draw-bar	1
111	Stop Rubber	1
112	Elastic Pin	1
113	Blade Spring	1
114	Spring	1
115	Elastic Pin	1
116	Elastic Pin	1
117	Control Handle	1
118	Roller	1
119	Elastic Pin	1
120		
121	Pull Board	1
122	Pin	1

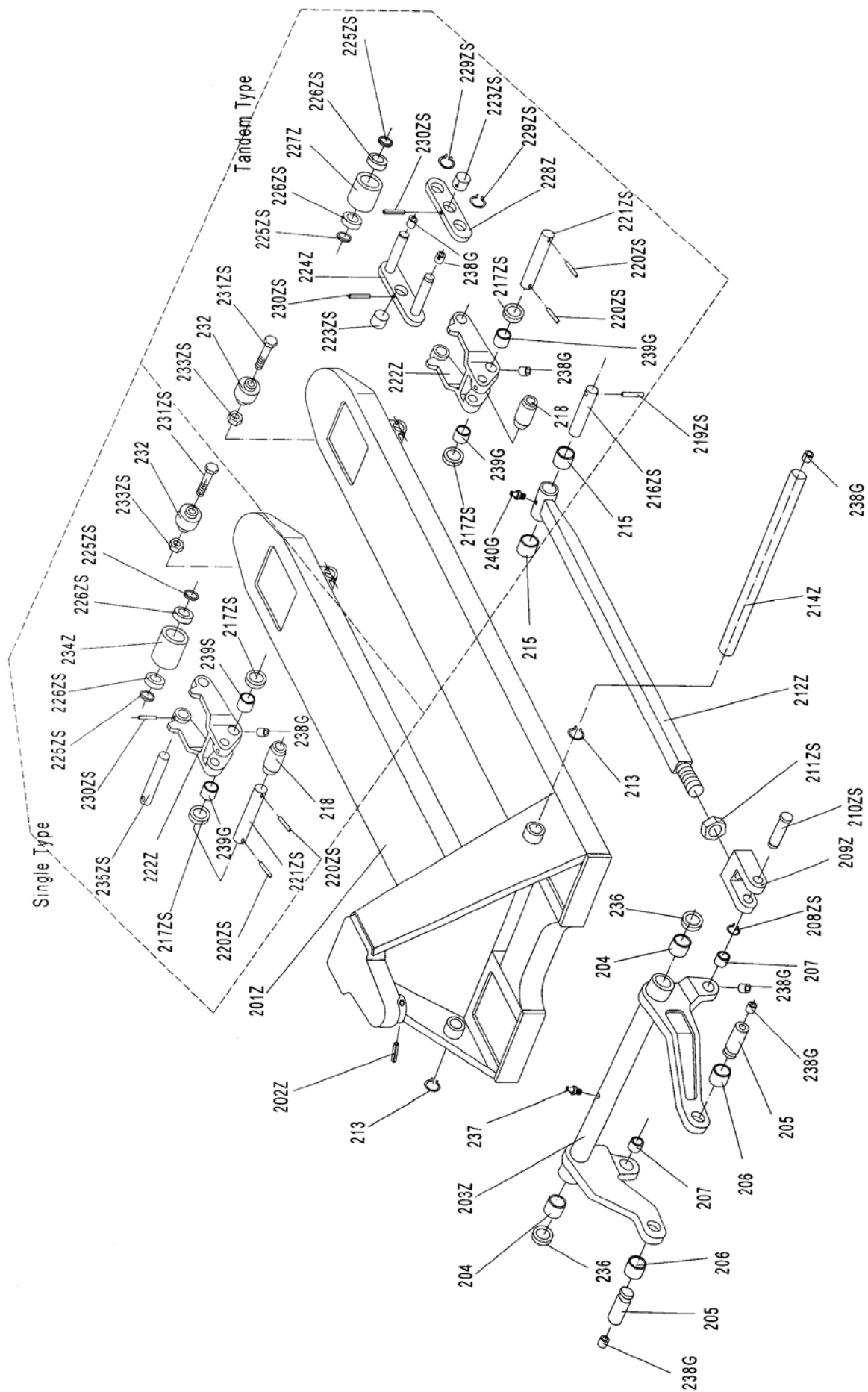

LIST of FORK FRAME

No.	Description	Quantity
201Z	Fork Frame	1
202Z	Elastic Pin	1
203Z	Rock - Arm	1
204	Bushing	2
205	Shaft	2
206	Bushing	2
207	Bushing	2
208ZS	Retaining Ring	2
209Z	Joint	2
210ZS	Pin	2
211ZS	Nut	2
212Z	Pushing Rod	2
213	Retaining Ring	2
214Z	Shaft	1
215	Bushing	4
216ZS	Shaft	2
217ZS	Intermediate Roller	4
218	Extending Roller	2
219ZS	Elastic Pin	2
220ZS	Elastic Pin	4
221ZS	Shaft	2
222Z	Frame of Roller	2
223ZS*	Shaft	4
224Z*	Tandem mounting with pin	4
225ZS	Washer	8 or 4
226ZS	Bearing	8 or 4
227Z*	Loading Roller	4
228Z*	Tandem Mounting	2
229ZS*	Spring Washer	4
230ZS	Elastic Pin	4 or 2
231ZS	Bolt	2
232	Enter Roller	2
233ZS	Locking Nut	2
234Z#	Loading Roller	2
235ZS#	Shaft for Roller	2
236	Washer	2
237	Grease Cup	1
238G	Grease Cup	14 or 8
239G	Bushing	4
240G	Grease Cup	2

NOTE: *-- For double wheel;#-- For single wheel

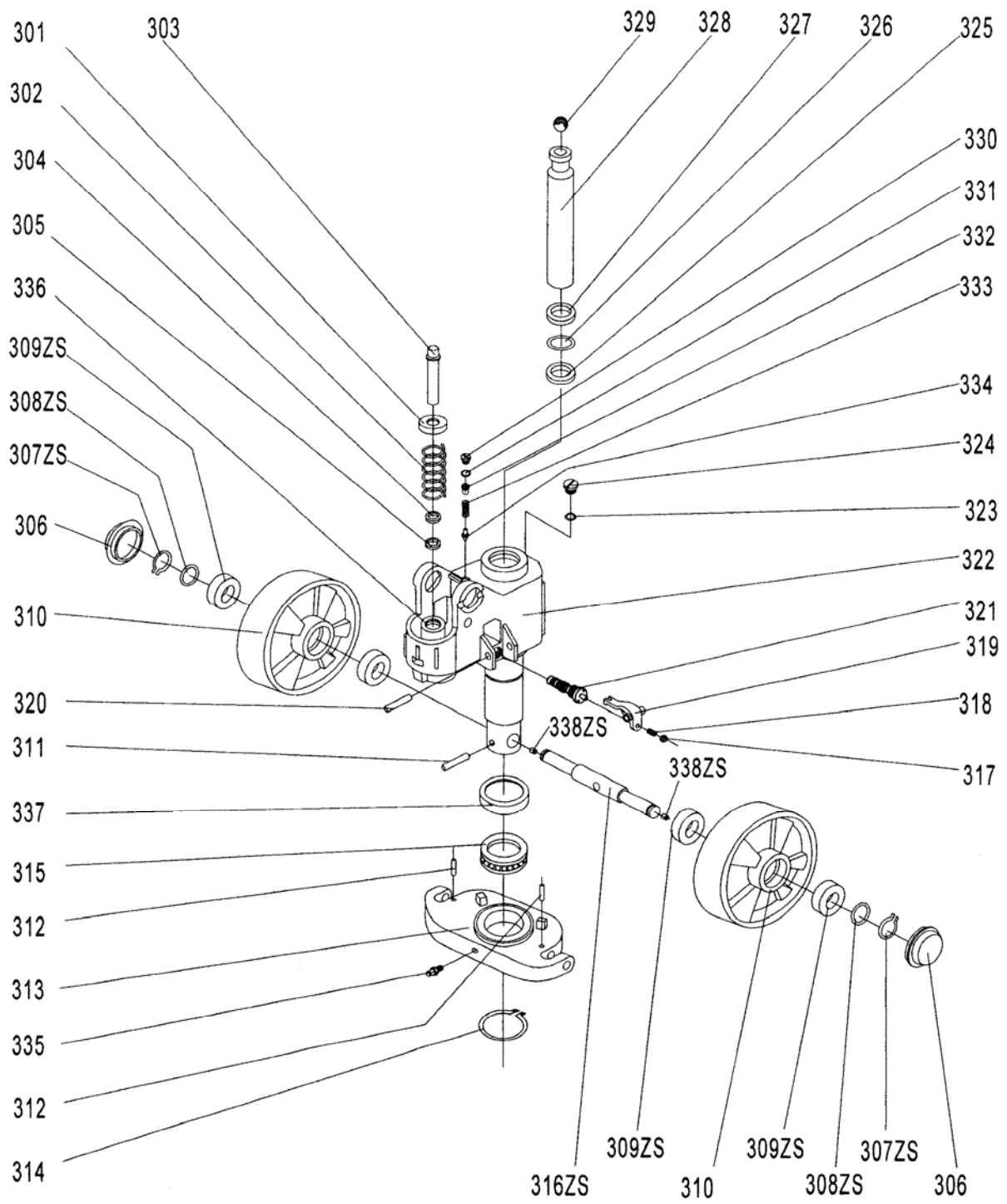

LIST of HYDRAULIC PUMP

No.	Description	Quantity
301	Spring Cap	1
302	Spring	1
303	Pump Piston	1
304	Dust Ring	1
305	Seal	1
306	Dust Cover	2
307ZS	Locking Ring	2
308ZS	Washer	2
309ZS	Bearing	4
310	Steering Wheel	2
311	Elastic Pin	1
312	Elastic Pin	2
313	Thrust Plate	1
314	Retaining Ring	1
315	Bearing	1
316ZS	Shaft of loading Wheel	1
317	Nut	1
318	Screw	1
319	Lever Plate	1
320	Elastic Pin	1
321	Valve Cartridge	1
322	Pump Body	1
323	Seal Washer	1
324	Screw Plug	1
325	Seal	1
326	O – Ring	1
327	Dust Ring	1
328	Piston Rod	1
329	Steel Ball	1
330	Screw Plug	1
331	O - Ring	1
332	Bolt	1
333	Spring	1
334	Spindle of Safety Valve	1
335	Grease Cup	1
336	Cylinder	1
337	Cover of Bearing	1
338ZS	Grease Cup	2